

New Unit Information



GP 40, GP 45, GP 55, GP 60
BPE 4000/45, BPE 4200/50, BPE 5000/55

1.645-...

General Information

- The unit is intended for use in the home and garden.
- Convenient foot switch (not GP 40).
- Comfortable carrying handle.
- Large filler neck for convenient venting (not GP 40).
- Including prefilter (not GP 40).
- Optimised connection sockets (not GP 40).
- Including non-return valve (BPE series only).
- Adjustable after-running time (BPE series only).
- Dry-running protection (BPE series only).
- Display, for displaying the operating data and fault display (BPE 4200/50 and BPE 5000/55 only).
- Remote control including programming function (GP 60 only).

Approved pumped liquids

- Industrial water.
- Well water.
- Spring water.
- Rainwater.
- Swimming pool water (subject to proper metering of the additives).

View from the front, BPE 5000/55



1 ON/OFF switch (S1)

2 Pump unit

3 Control buttons

4 Display

5 Status display

6 Base feet

7 Drain opening with bearing flowmeter

8 Unit housing

9 Connection, suction line

10 Filler neck with prefilter

11 Connection, pressure line

View from the front, GP 60



- 1 ON/OFF switch (S1)
- 2 Pump unit
- 3 Remote control
- 4 Base feet

- 5 Drain opening
- 6 Unit housing
- 7 Connection, suction line
- 8 Filler neck with prefilter
- 9 Connection, pressure line

Functional diagram BPE 5000/55

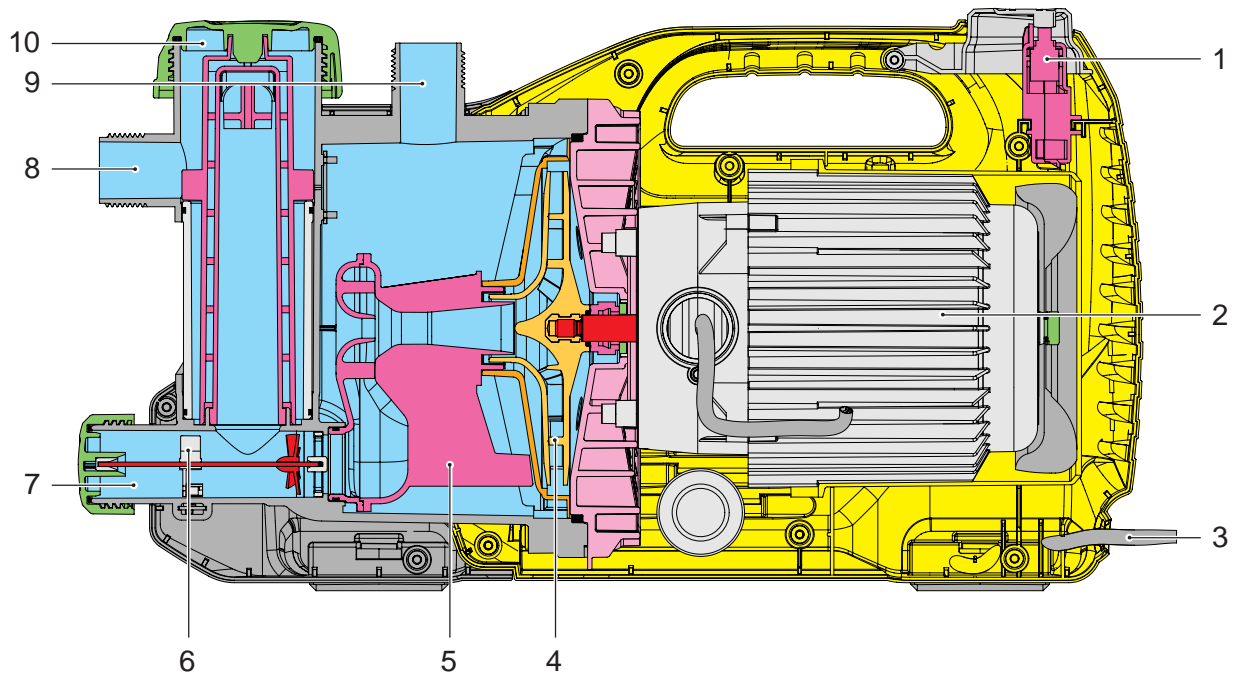

- | | |
|----------------------|--|
| 1 ON/OFF switch (S1) | 6 Flowmeter |
| 2 Motor (M) | 7 Drain opening with bearing flowmeter |
| 3 Mains cable | 8 Connection, suction line |
| 4 Guide vane | 9 Connection, pressure line |
| 5 Contents injector | 10 Filler neck with prefilter |

Functional diagram GP 60

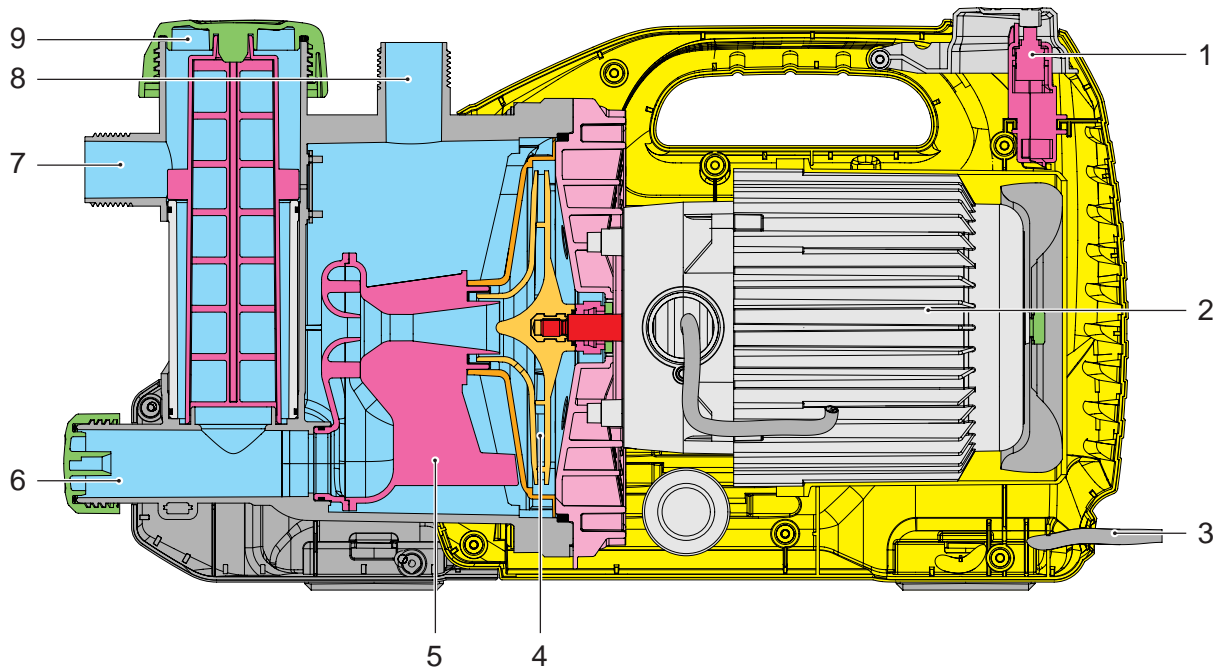

- 1 ON/OFF switch (S1)
- 2 Motor (M)
- 3 Mains cable
- 4 Guide vane
- 5 Contents injector

- 6 Drain opening
- 7 Connection, suction line
- 8 Connection, pressure line
- 9 Filler neck with prefilter

Removing the unit housing

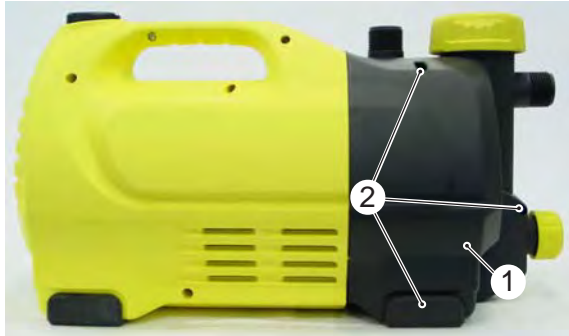

Unit housing

Removing the unit housing

Loosen the screws (2) and remove the unit housing (1).

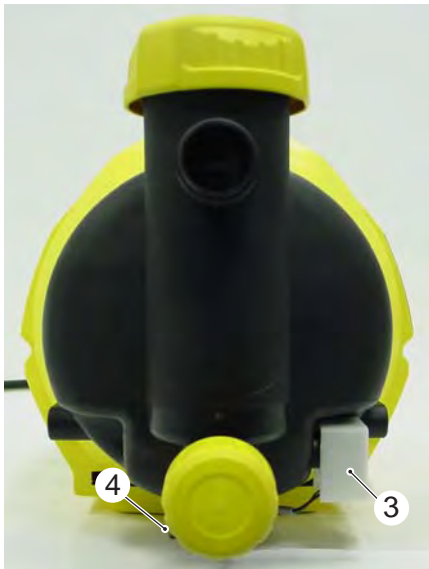

Pressure switch with cap, flowmeter sensor

- 1 Unit housing
- 2 Screws, unit housing
- 3 Pressure switch (S2) with cap (BPE 5000/55 only)
- 4 Sensor, flowmeter

Removing the flowmeter

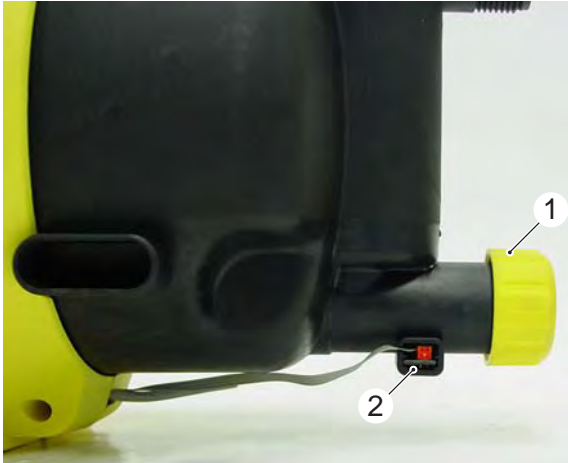

Sensor, flowmeter

Removing the flowmeter

Remove the cover (1) of the drain opening. Remove the flowmeter (3) and corresponding bearing (4) from the drain opening.

Note:

During the assembly ensure that the bearing (4) is not canted (tilted) when inserted in the drain opening and the cover (1) is correctly screwed on. Otherwise proper function of the flowmeter (3) is not ensured.



Flowmeter

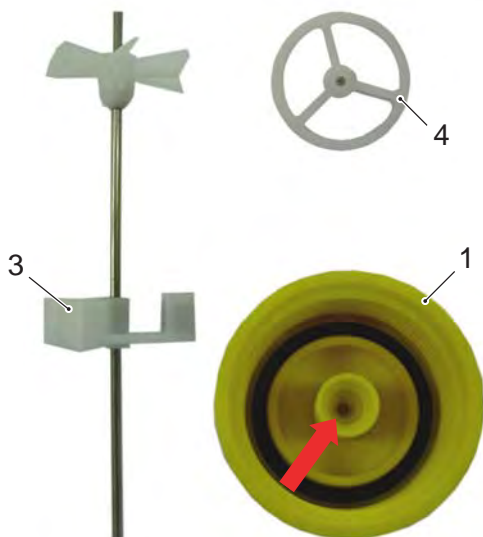

Bearing, flowmeter

- 1 Cover, drain opening
- 2 Sensor, flowmeter
- 3 Flowmeter
- 4 Bearing, flowmeter

Removing the pressure sensor

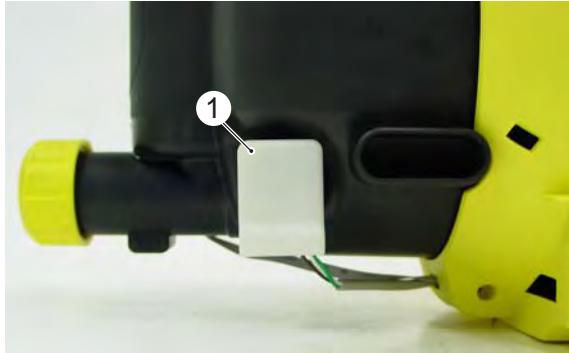

Cap, pressure sensor

Removing the pressure sensor

Remove the cap (1) on the pressure sensor. Pull off the connecting plug (3) and remove the pressure sensor (2).

Note:

Grease the O-ring (4) when assembling.

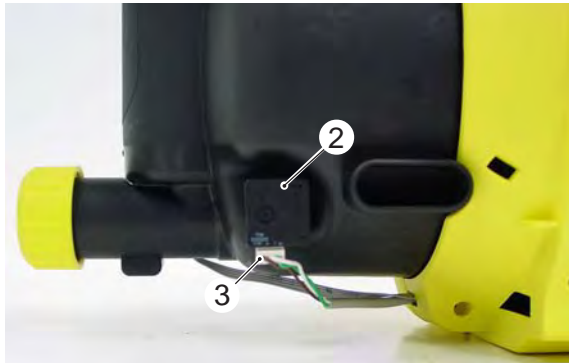

Connection, pressure sensor

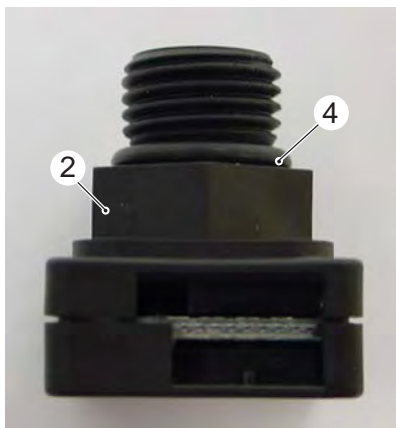

Pressure sensor

- 1 Cap, pressure sensor
- 2 Pressure sensor (S3) (BPE 5000/55 only, otherwise pressure switch (S2))
- 3 Connecting plug, pressure sensor
- 4 O-ring, pressure sensor

Removing the pump unit

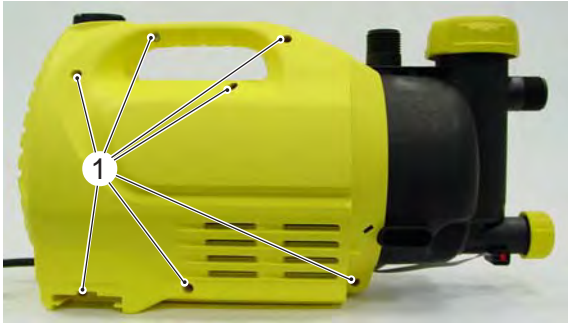

Pump unit

Removing the pump unit

Loosen the screws (2) of the pump head (1).
Remove the motor housing (3).

Remove the circlip (4) and remove the motor fan (5).

Note:

Use new sealing cord (3) for the assembly.
Ensure that the sealing cord (3) is correctly inserted in the groove provided for it.

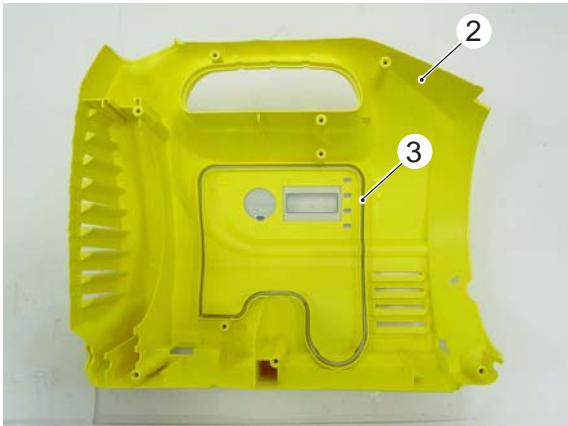

One half of pump housing

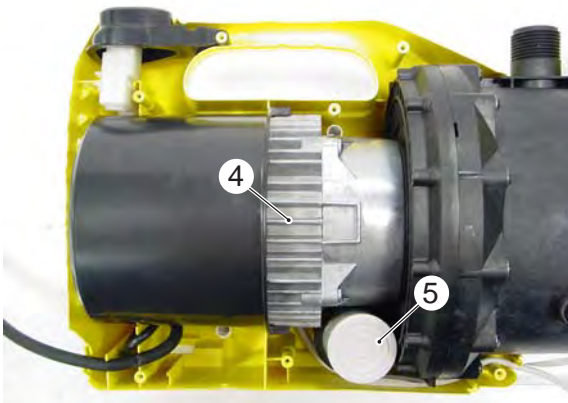

One half of pump housing removed

- 1 Screws, pump housing
- 2 Pump housing
- 3 Sealing cord
- 4 Motor (M)
- 5 Capacitor (C)

Removing the impeller

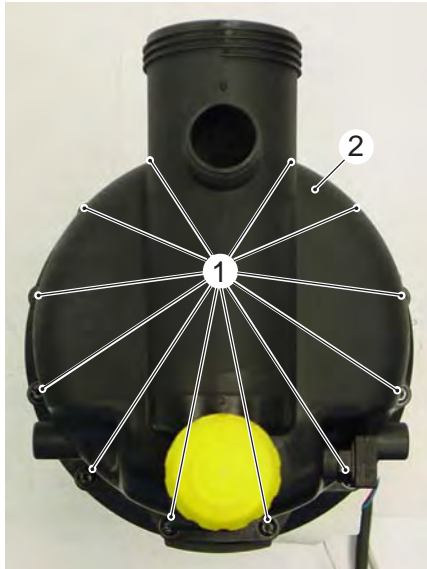

Pump head

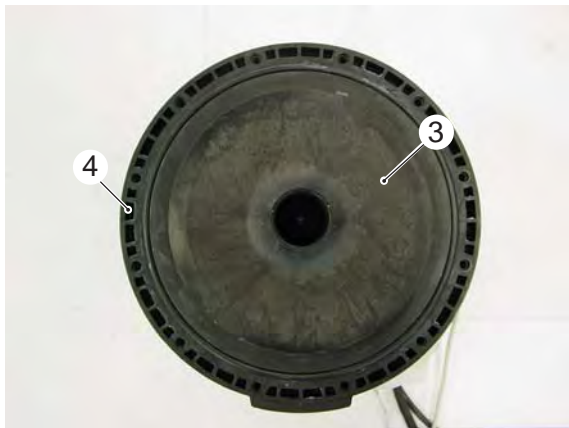

Wheel

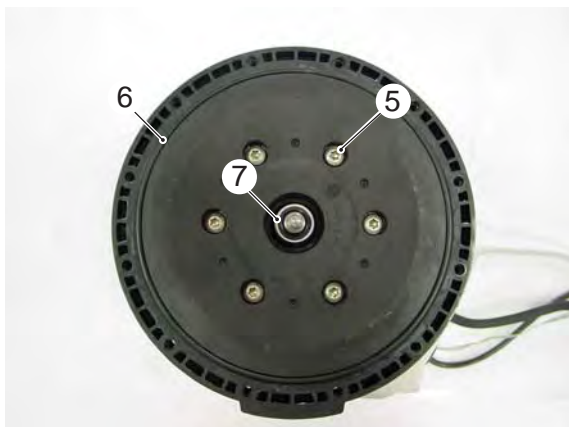

Mechanical seal

Removing the impeller

Remove the screws (1) and remove the pump head (2).

Remove the impeller (3) by turning it in an anti-clockwise direction (to do this, remove the motor fan, see page 11, and hold the motor shaft in place by pressing a suitable tool against it).

Note:

If the pump head (2) is removed the O-ring (6), see page 10 also, must be replaced.

If the Teflon sealing ring (7) is removed it must be replaced.

- 1 Screws, pump head
- 2 Pump head
- 3 Wheel
- 4 Pump flange
- 5 Screws, pump flange
- 6 O-ring
- 7 Mechanical seal

Removing the impeller

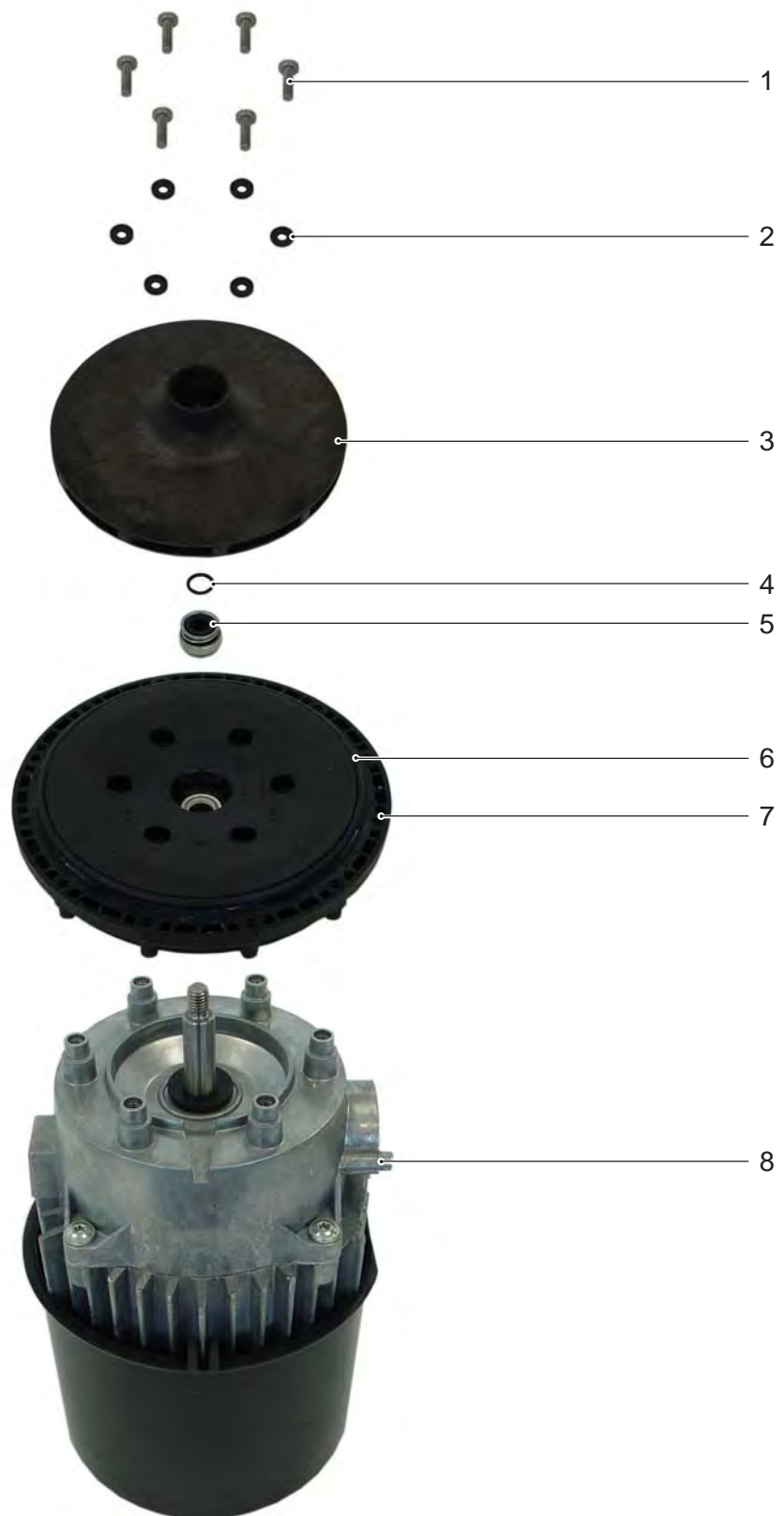

- 1 Screws, pump flange
- 2 Seals
- 3 Wheel
- 4 O-ring, 12x2

- 5 Mechanical seal
- 6 O-ring, 160x5
- 7 Pump flange
- 8 Motor (M)

Removing the motor fan



Motor with motor fan

Removing the motor fan

Remove the screw (3) (at the same time, using a suitable tool to hold the motor fan (2) in place) and remove the motor fan (2).

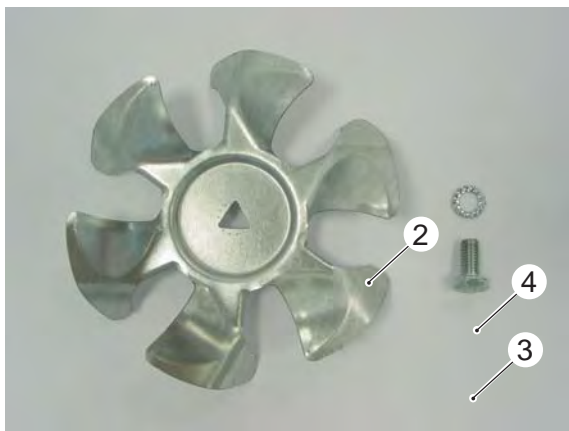

Motor fan

- 1 Motor (M)
- 2 Motor fan
- 3 Screw, motor fan
- 4 Tooth lock washer, motor fan

Removing the printed circuit board (A1), BPE

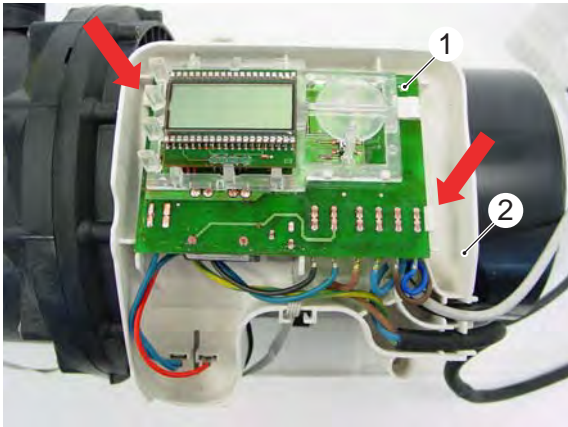

Removing the printed circuit board (A1), BPE

Unclip the printed circuit board (1) (red arrow) and remove from the front.

Note:

The O-ring (4) must be replaced if the housing (2) is removed.

Grease the O-ring (4) when assembling.

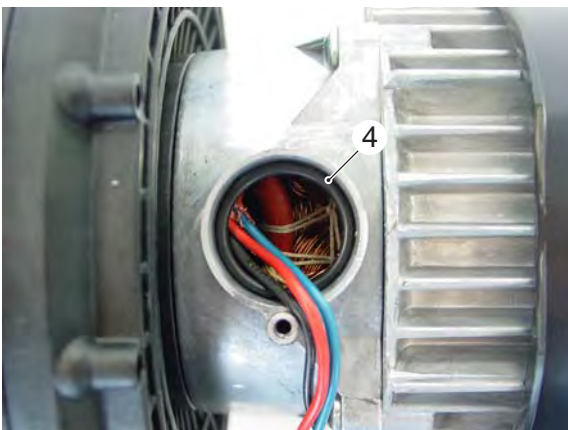
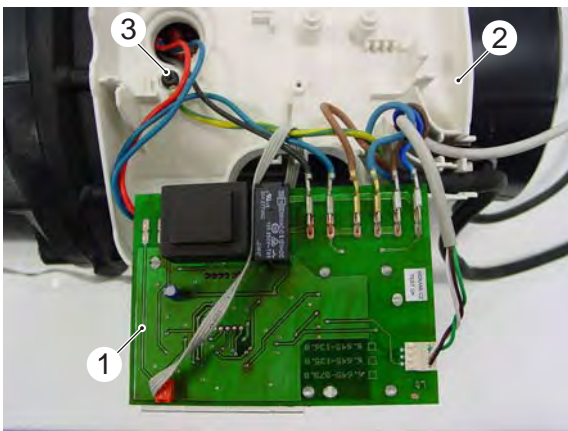

- 1 Printed circuit board (A1), BPE
- 2 Housing, BPE printed circuit board
- 3 Connection, earth conductor
- 4 O-ring

BPE printed circuit board (A1)

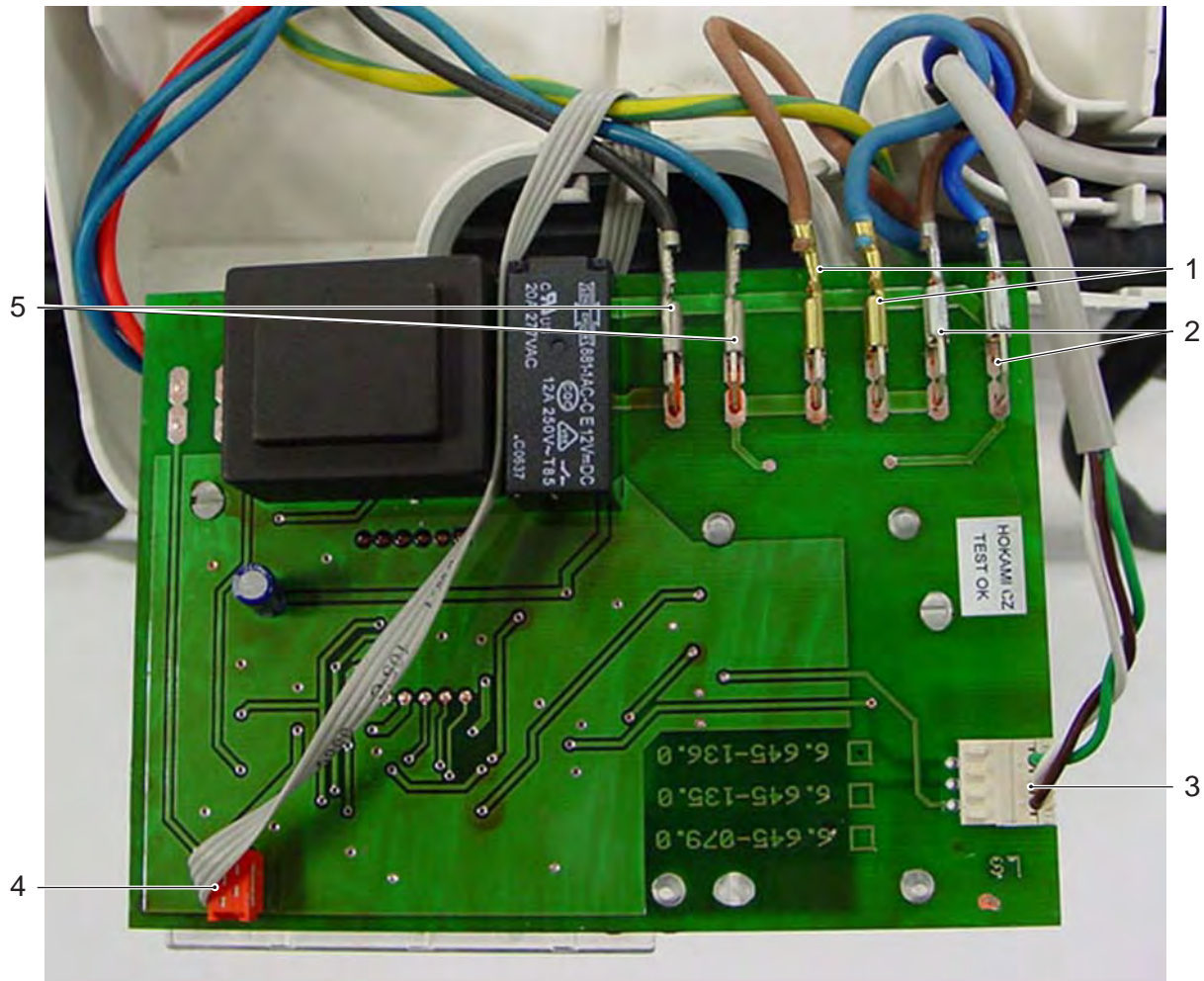

- 1 Mains cable
- 2 Connection cable, ON/OFF switch (S1)
- 3 Connection cable, pressure sensor (S3)
(BPE 5000/55 only, otherwise pressure switch (S2))

- 4 Connection cable, flowmeter
- 5 Connection cable, motor (M)

Removing the printed circuit board (A2), GP

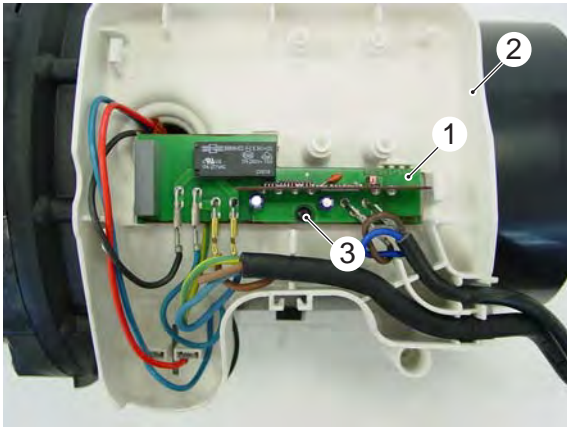

Removing the printed circuit board (A2), GP

Remove screw (3) and remove the printed circuit board (1).

Note:

The O-ring (4) must be replaced if the housing (2) is removed.

Grease the O-ring (4) when assembling.

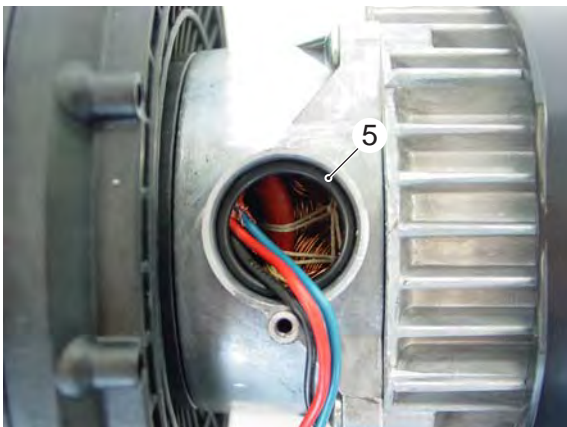
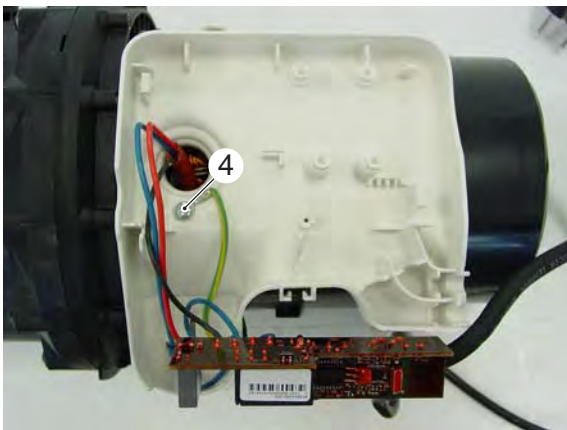

- 1 Printed circuit board (A2), GP
- 2 Housing, GP printed circuit board (A2)
- 3 Screw, GP printed circuit board (A2)
- 4 Connection, earth conductor
- 5 O-ring

GP printed circuit board (A2)

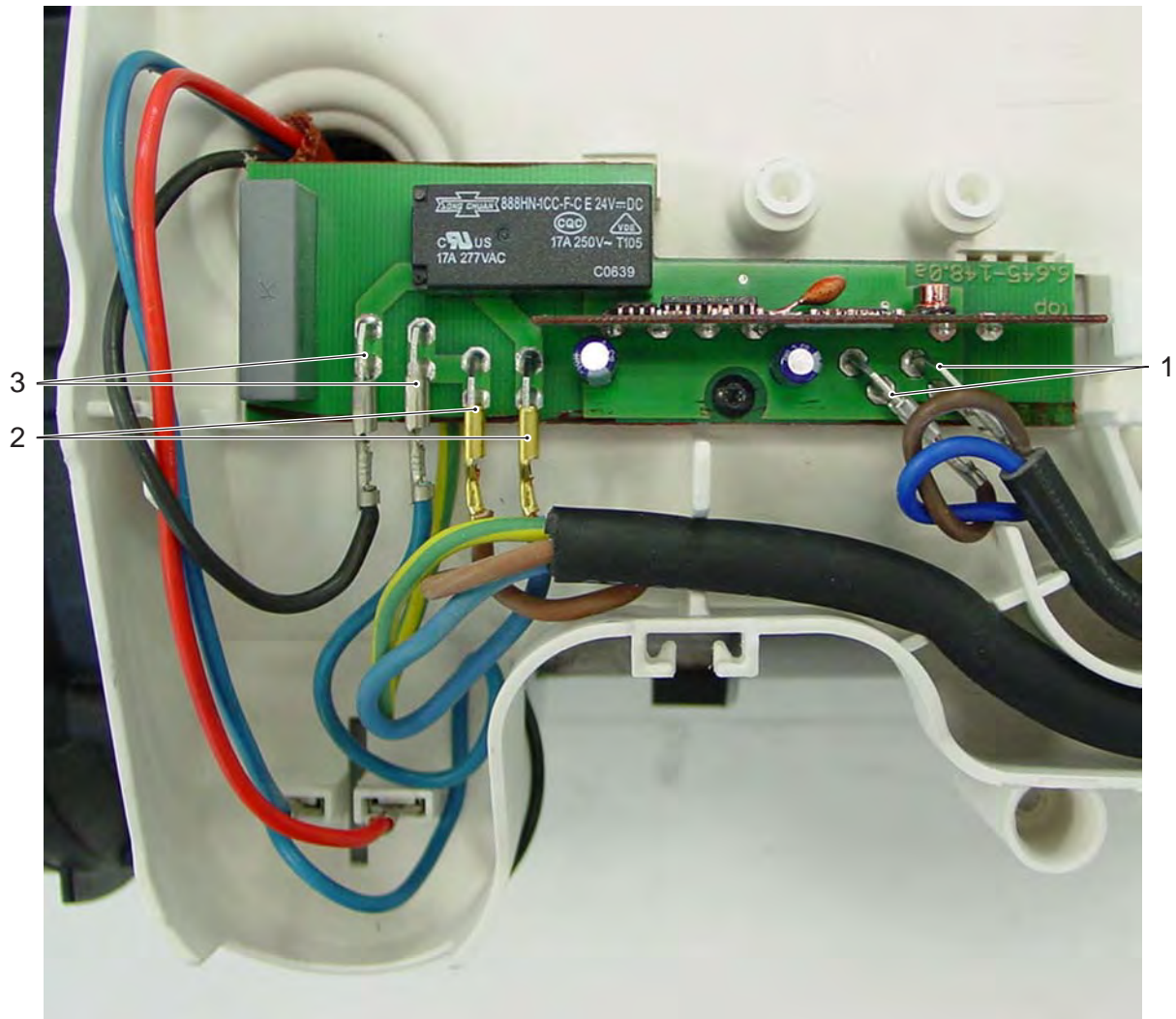

- 1 Connection cable, ON/OFF switch (S1)
- 2 Mains cable
- 3 Connection cable, motor (M)

Removing the motor (M)

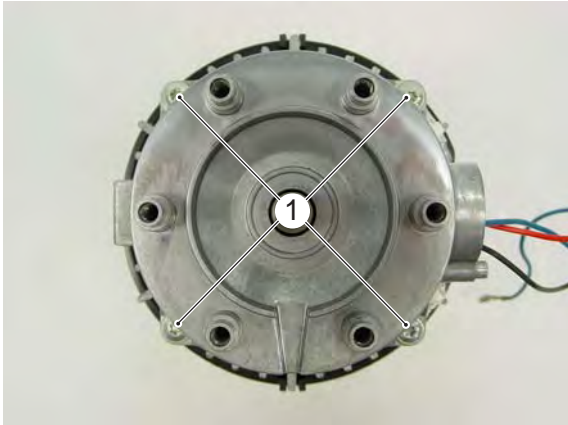

Engine

Removing the motor (M)

Remove the screws (1) and remove the motor cover (3) from the motor housing (2).

Pull the motor shaft (4) from the motor housing (2).

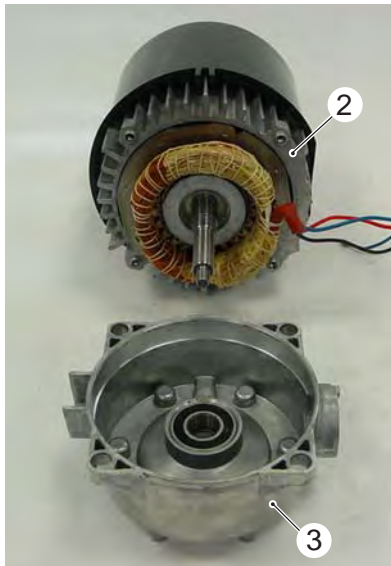

Motor housing

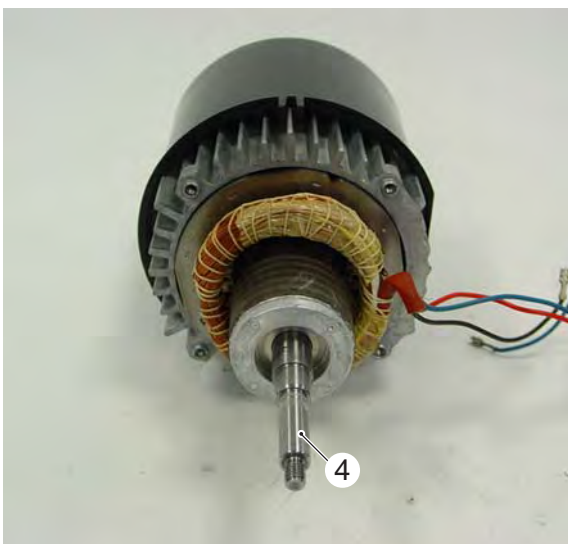

Motor shaft

- 1 Screws, motor housing
- 2 Motor housing
- 3 Motor cover
- 4 Motor shaft

Removing the injector



Pump head

Removing the injector

Pull the guide vane (1) and injector (2) out of the pump head (3).

Note:

The O-ring (5) must be replaced if the injector (2) is removed. Grease the O-ring (5) when assembling.

When assembling the injector (2) it must be firmly pushed into the inlet (4) of the pump head (3).



Pump head inlet

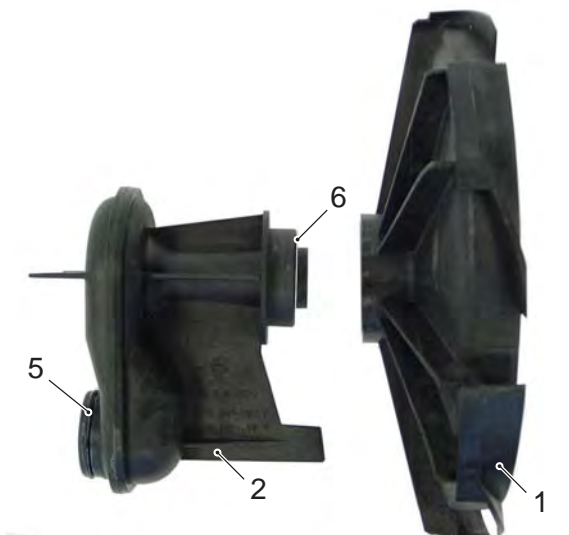

Contents injector

- 1 Guide vane
- 2 Contents injector
- 3 Pump head
- 4 Inlet, pump head
- 5 O-ring
- 6 Metal ring

Remote control, GP 60 only



- 1 Display
- 2 ENTER input key
- 3 ON / + input key
- 4 OFF / – input key
- 5 MODE selection key

Remote control, GP 60 only

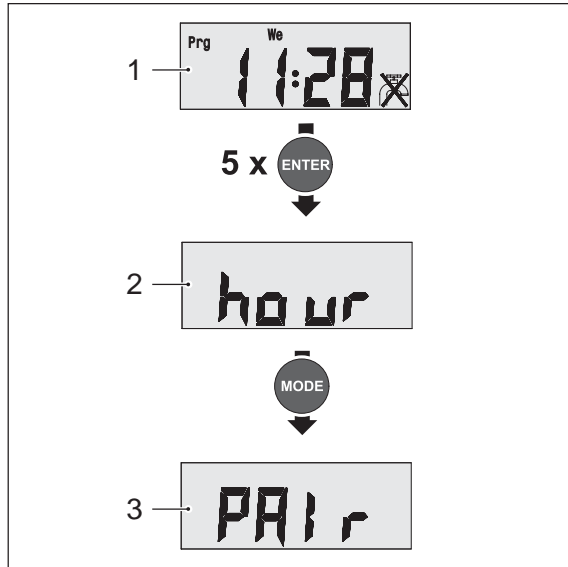

Pair selection

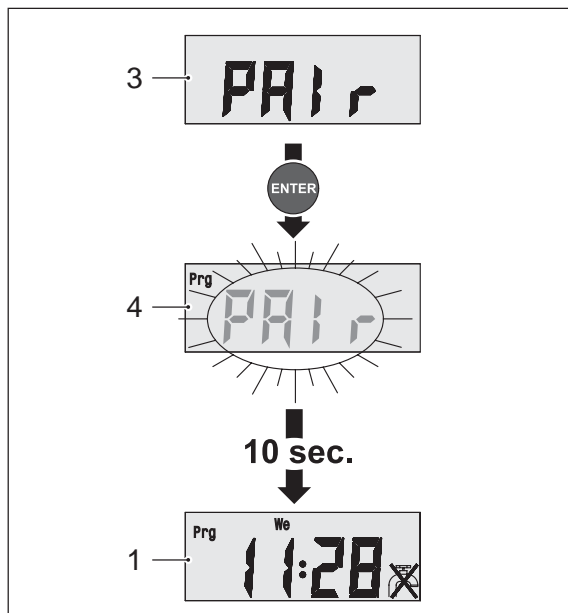

Matching (pairing)

- 1 Default display
- 2 „Adjust clock“ display
- 3 „Pair transmitters“ display
- 4 „Transmitter pairing active“ display

Matching the transmitters (pairing)

The hand-held transmitter is matched to the pump in the factory, it only needs adjusting if the hand-held transmitter is replaced. The transmitter matching (pairing) can only be carried out up to max. 30sec. after switching on the pump and the distance to the pump must not exceed 5m. Successful pairing is confirmed by brief starting up of the pump.

Transmitter matching (pairing) sequence

(see also page 18)

- During the display in initial state, default display (1), press the ENTER key 5 times until the „hour“ display appears.
- Press the MODE selection key once to activate the „Pair transmitters“ menu.
- Press the ENTER key once; pair is activated and the „Transmitter pairing activated“ display flashes for 10sec.
- The default display then re-appears and pairing is completed.

Circuit diagram 0.088-992.0 (GP 40, GP 45, GP 55)

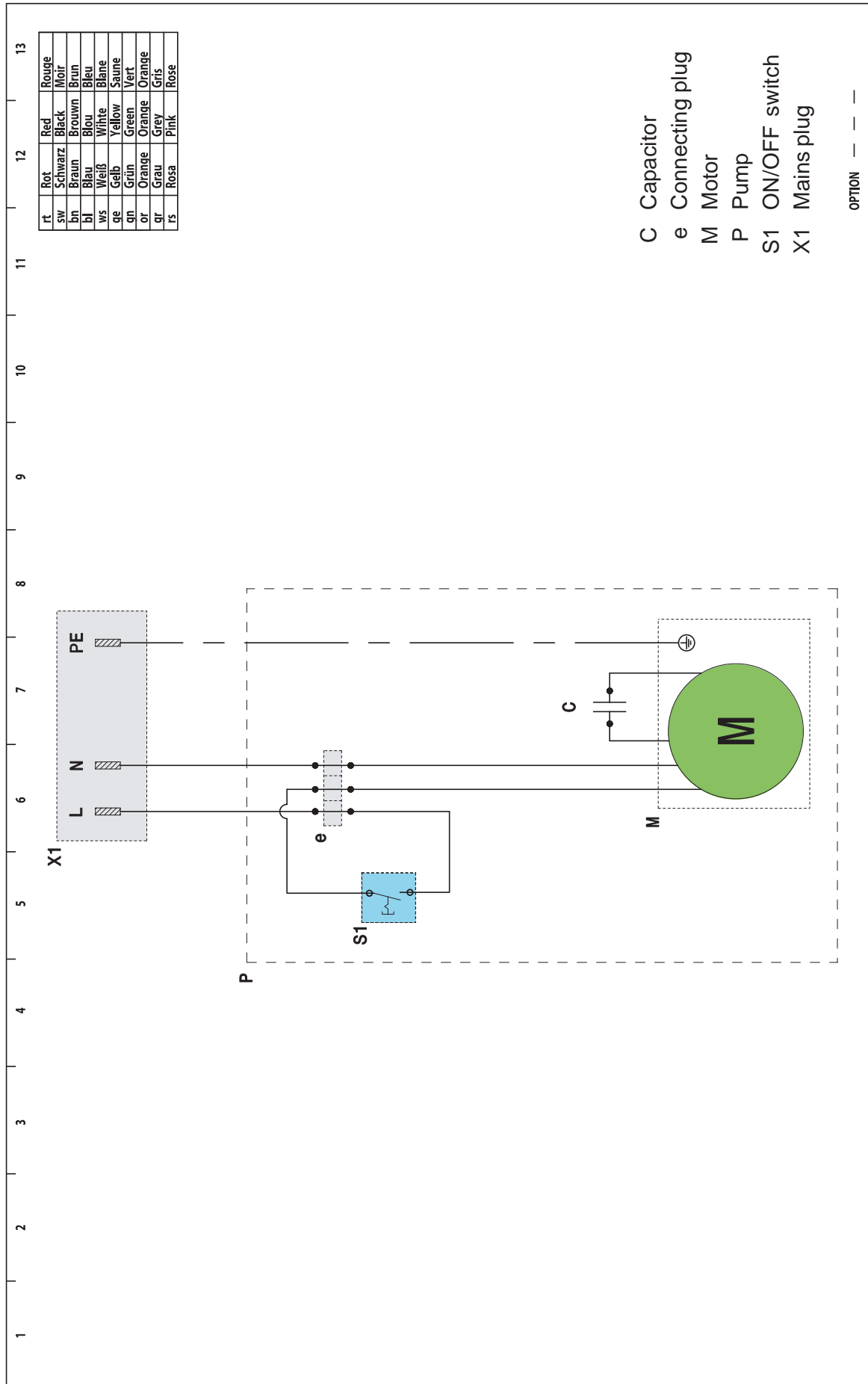

Circuit diagram 0.088-993.0 (GP 60)

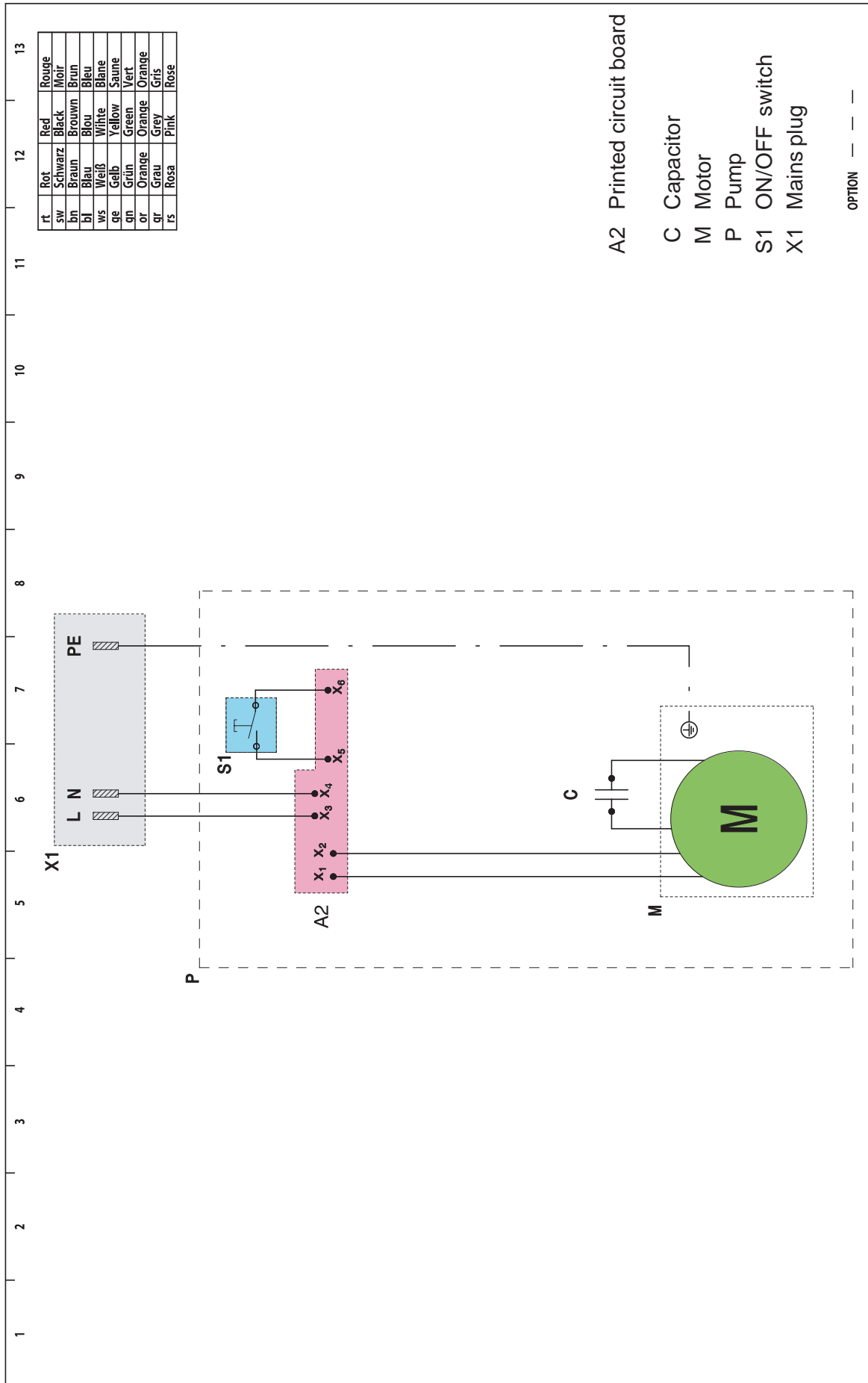

Circuit diagram 0.088-994.0 (BPE 4000/45, 4200/50)

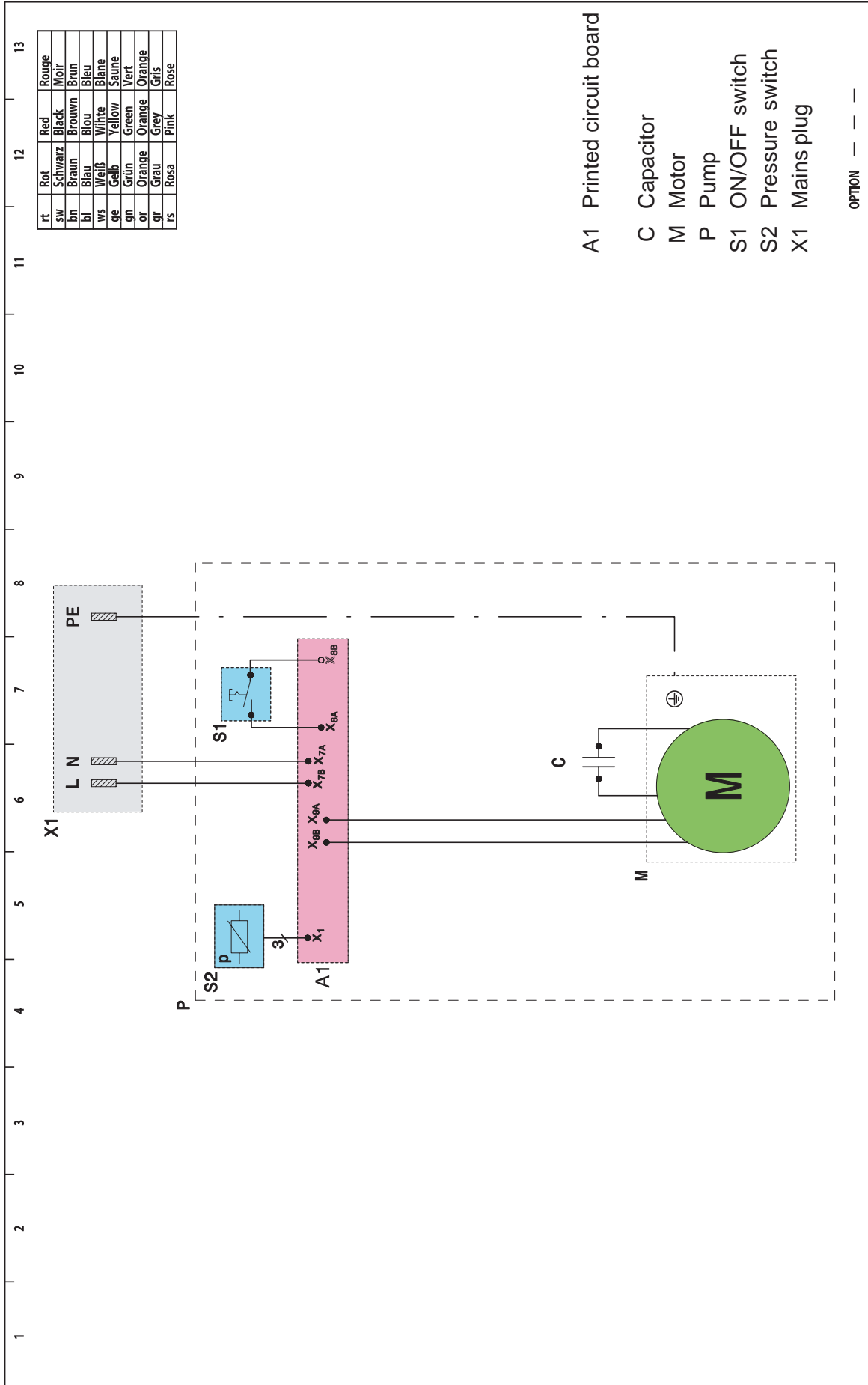

Circuit diagram 0.088-985.0 (BPE 5000/55)

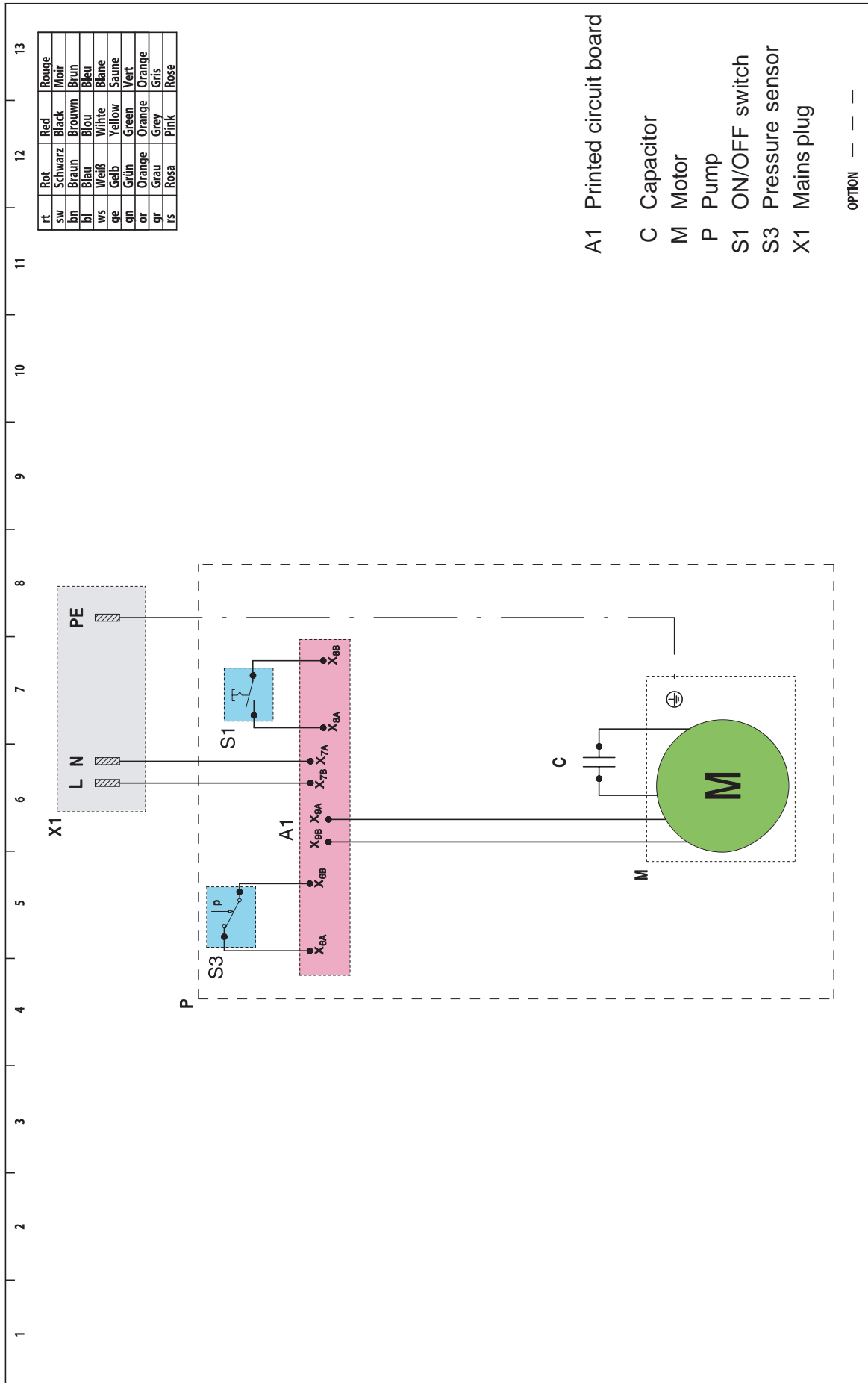

Troubleshooting

Fault	Solution
Pump (P) is running but does not pump	<ul style="list-style-type: none"> – Fill filler neck with water again. – Open the tap on the pressure side. – Clean the prefilter.
Pump (P) does not start up or stops suddenly during operation	<ul style="list-style-type: none"> – Check/replace fuses and electrical connections. – Check/replace cable, plug and plug socket. – Allow pump (P) to cool (thermostatic switch in the motor (M) has tripped). – Clean suction area. – Clean the prefilter. – Check power supply to motor (M). – Check/replace capacitor (C). – Check/replace motor (M).
Pump (P) unexpectedly switches on or off (GP 60 only)	<ul style="list-style-type: none"> – Check the remote control setting.
Pump (P) does not respond to the remote control (GP 60 only)	<ul style="list-style-type: none"> – Change the batteries.
Delivery rate falls or is too low	<ul style="list-style-type: none"> – Clean suction filter or non-return valve. – Note max. delivery head. – Clean the prefilter.
Pump (P) stops, „Err1“ appears in the display, all the lights are flashing (BPE series)	<ul style="list-style-type: none"> – Clean the prefilter. – Check connections on suction (inlet) side for leak. – Check non-return valve. – Check function of flowmeter.
Pump (P) stops, „Err2“ appears in the display, 2 lights at a time flash alternately (BPE series)	<ul style="list-style-type: none"> – Requires the use of low water removal. – Gradually increase the after-running time. – Check pressure side for leak.
Pump (P) stops briefly and then switches back on, „Err2“ appears in the display after several switching operations, 2 lights at a time flash alternately (BPE series)	<ul style="list-style-type: none"> – Check function of non-return valve.

Technical specifications

Units Type	Output	Flow rate	Max. suction head	Delivery head/ Max. pressure of the pump	Working pressure
GP 40	650 W	3000 l/h	9 m	36 m / 3.6 bar (52.2 psi)	–
GP 45	850 W	3800 l/h	9 m	43 m / 4.3 bar (62.4 psi)	–
GP 55	1100 W	4300 l/h	9 m	49 m / 4.9 bar (71 psi)	–
GP60	1300 W	4500 l/h	9 m	55 m / 5.5 bar (79.8 psi)	–
BPE 4000 / 45	850 W	3800 l/h	9 m	44 m / 4.4 bar (63.8 psi)	1.6 - 4.4 bar (23.2 - 63.8 psi)
BPE 4200 / 50	1100 W	4200 l/h	9 m	49 m / 4.9 bar (71 psi)	1.6 - 4.9 bar (23.2 - 71 psi)
BPE 5000 / 55	1300 W	4800 l/h	9 m	55 m / 5.5 bar (79.8 psi)	1.6 - 5.5 bar (23.2 - 79.8 psi)

Unit type	Unit No.	Circuit diagram	Operating instructions	Spare parts list
GP 40	1.645-200	0.088-992	5.962-135.0	5.970-776.0
GP 45	1.645-201	0.088-992	5.962-180.0	5.970-732.0
GP 55	1.645-202	0.088-992	5.962-180.0	5.970-732.0
GP 60	1.645-203	0.088-993	5.962-181.0	5.970-793.0
BPE 4000 / 45	1.645-250	0.088-994	5.962-173.0	5.970-728
BPE 4200 / 50	1.645-251	0.088-994	5.962-182.0	5.970-728
BPE 5000 / 55	1.645-252	0.088-985	5.962-182.0	5.970-728

The technical data sheet and the circuit diagram will be included in the next issue of the spare parts CD-ROM (DISIS) and are also available in kaercher-inside (<https://kaercher-inside.com>).

If required, the operating instructions and the spare parts lists can be ordered as a paper copy from the spare parts service by quoting the relevant part number.

Special tools

No details.

Tightening torque

No details.

Index

B

Base feet 3, 4
 Bearing 8

C

Cap 9
 Capacitor 10
 Circuit diagram 22-25
 Connecting plug, pressure switch 9
 Connection, pressure line 3-6
 Connection, suction line 3-6
 Contents injector 5, 6, 19
 Control buttons 3
 Cover 8

D

Display 3
 Drain opening 3-6

E

Engine 10, 12, 13, 18

F

Filler neck with prefilter 3-6
 Flowmeter 5, 7

G

Guide vane 5, 6, 19

H

Housing 14

I

Inlet 19

M

Mains cable 5, 6, 15, 17
 Mechanical seal 11, 12
 Motor cover 18
 Motor fan 12
 Motor housing 18
 Motor shaft 18

O

ON/OFF switch 3-6
 O-ring 9, 11, 12, 14, 16, 19

P

Pair transmitters 21
 Pairing 21
 Pressure switch 7, 9
 Printed circuit board 14-17
 Pump flange 11, 12
 Pump head 11, 19
 Pump housing 10
 Pump unit 3, 4, 10

R

Rectifier 15, 17
 Remote control 4, 20, 21

S

Sealing cord 11
 Seals 13
 Sensor 7, 8
 Status display 3

T

Technical specifications 25
 Tooth lock washer 13
 Troubleshooting 26

U

Unit housing 3, 4, 7

V

Voltage transformer 15, 17

W

Wheel 11, 12