

50 Accessories (0.164-821.0)

Overview technical documents/Professional/Suction apparatus/Wet-/dry vacuum cleaner/NT 45/1 Tact Te *EU (1.145-818.0)/Spare parts list NT 45/1 Tact Te/50 Accessories (0.164-821.0)

K6902154

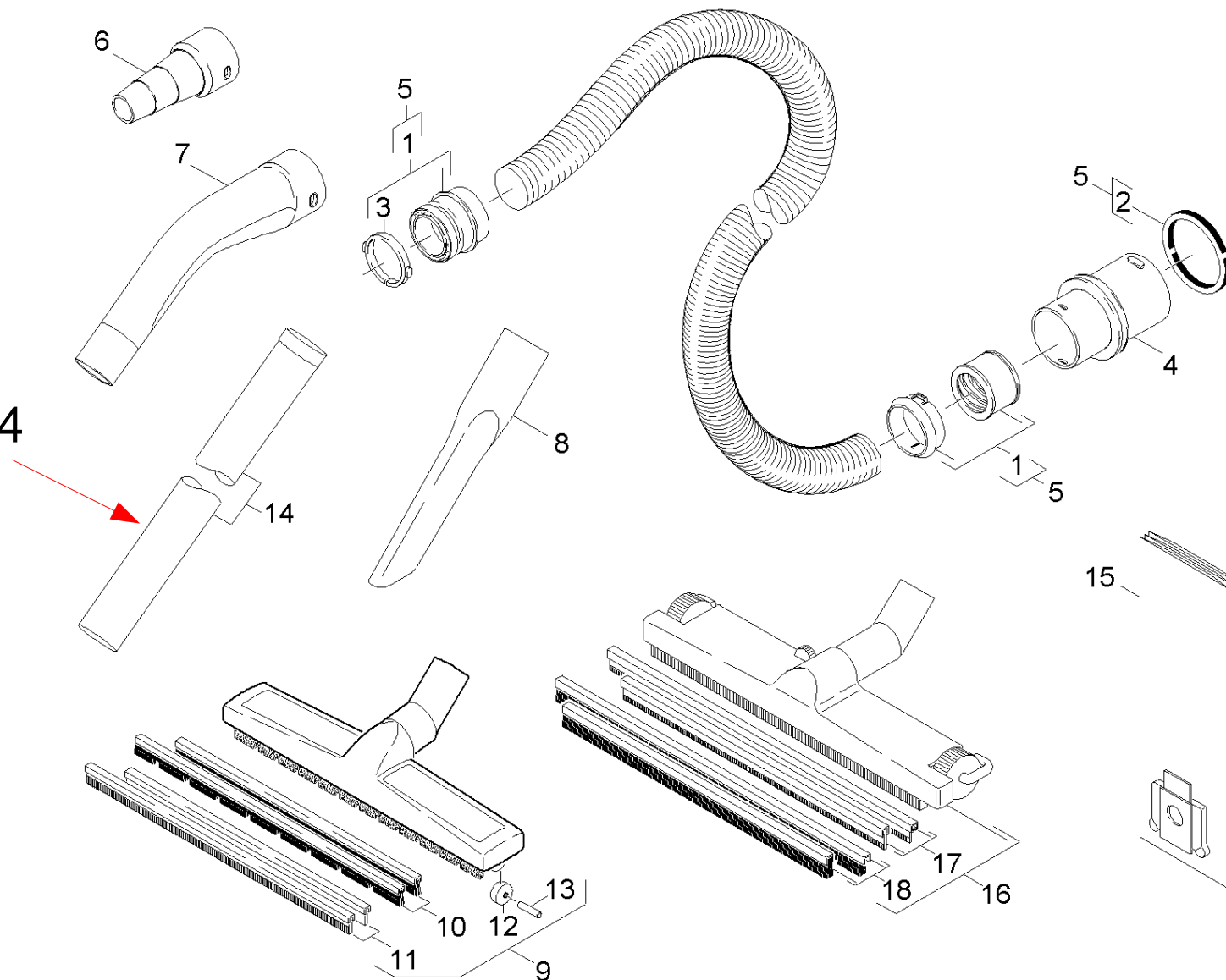

50 Accessories (0.164-821.0)

Overview technical documents/Professional/Suction apparatus/Wet-/dry vacuum cleaner/NT 45/1 Tact Te *EU (1.145-818.0)/Spare parts list NT 45/1 Tact Te/50 Accessories (0.164-821.0)

ET/VT (spare/wear parts)	Pos	Material #	Name	Qty.	Unit	from ser.nr.	up to ser.nr.
X	1	2.639-690.0	Repair set	1.000	ST	00000000000000000000	00000000000000000000
X-X	2	6.273-202.0	Cord cellular rubber	1.000	ST	00000000000000000000	00000000000000000000
X-X	3	5.031-703.0	Tension ring C35	1.000	ST	00000000000000000000	00000000000000000000
	4	5.443-464.0	Hosebarb	1.000	ST	00000000000000000000	00000000000000000000
X	5	6.906-275.0	Suction hose C35	1.000	ST		
Position text: /1.145-814.0							
X-X	5	4.440-626.0	Suction hose C DN35	1.000	ST	00000000000000000000	00000000000000000000
Position text: /1.145-806.0 / -818.0							
X-X	6	5.453-042.0	Sleeve for tool C35EL	1.000	ST		
X-X	7	5.031-718.0	Elbow	1.000	ST	00000000000000000000	00000000000000000000
Position text: /1.145-806.0 / -818.0							
X-X	7	5.031-939.0	Elbow	1.000	ST		
Position text: /1.145-814.0							
X-X	8	6.906-240.0	Crevice nozzle DN35	1.000	ST	00000000000000000000	00000000000000000000
X-X	9	6.903-284.0	Floor tool DN35	1.000	ST	00000000000000000000	00000000000000000000
X-X	10	6.903-278.0	Brush strips set	1.000	ST	00000000000000000000	00000000000000000000
X-X	11	6.903-277.0	Set suction lips	1.000	ST	00000000000000000000	00000000000000000000
X-X	12	6.435-292.0	Roller only for replacement	2.000	ST	00000000000000000000	00000000000000000000
X-X	13	6.437-026.0	Axle	2.000	ST	00000000000000000000	00000000000000000000
X-X	14	6.902-154.0	Suction tube	2.000	ST		
X-X	15	6.904-208.0	Filter bag 5St. Kae.	1.000	ZSA	00000000000000000000	00000000000000000000
X-X	16	6.906-384.0	Floor tool neutrally DN35	1.000	ST		
Position text: /1.145-818.0							
X-X	17	6.903-062.0	Rubber strip set	1.000	ST		
Position text: /1.145-818.0							

50 Accessories (0.164-821.0)

Overview technical documents/Professional/Suction apparatus/Wet-/dry vacuum cleaner/NT 45/1 Tact Te *EU (1.145-818.0)/Spare parts list NT 45/1 Tact Te/50 Accessories (0.164-821.0)

ET/VT (spare/wear parts)	PosMaterial #	Name	Qty.	Unit	from ser.nr.	up to ser.nr.
X-X	18	6.903-064.0Brush strip set	1.000	ST		
Position text: /1.145-818.0						