

**Rezerves daļu saraksts
(5.958-795.0) Spare parts list HD 830 BS *EU**

DE HINWEISE

Weitere Sprachen:

Diese Ersatzteilliste ist in weiteren Sprachen erhältlich. Sie erhalten diese unter www.kaercher.com im Bereich Service. Die Schreibweise der Teilenummer, z.B. 75456380, entspricht der Teilenummer 7.545-638.0.

Mengenangaben:

Die Mengenangaben in der Ersatzteilliste entsprechen den in der Baugruppe verbauten Stückzahlen der Bauteile.

Meterware:

Ersatzteile welche als Meterware geliefert werden sind auf Einbaulänge selbst zu kürzen. Die Stückzahlen sind als Mindestbestellmenge =1m angegeben und müssen je nach Bedarf auf weitere volle Meterzahlen erhöht werden.

Versionen/ Werknummern:

Sind Versionen oder Werknummern in der Ersatzteilliste angegeben, ist anhand dieser vor Bestellung zu prüfen, welches Bauteil für ihr Gerät verwendet werden muss.

Lackierte Teile:

Bei Bestellungen von lackierten Teilen welche in der Ersatzteilliste nicht in verschiedenen Farben ausgewiesen sind, ist zusätzlich die Farbnummer oder Farbe mit anzugeben.

Technische Änderungen:

Technische Änderungen sowie das Recht der ausschließlichen Auswertung unseres geistigen Eigentums behalten wir uns vor.

EN INSTRUCTIONS

Other languages:

This list of spare parts is also available in other languages. You can get this list from www.kaercher.com in the Service division. The designation of the part number e.g. 75456380 is equal to 7.545-638.0.

Quantity details:

The quantity details in the spare parts list correspond to the number of pieces of the component installed in the assembly group.

Piece goods:

Spare parts that are sold as piece goods are to be cut to the desired length. The quantities have been indicated as minimum order quantity =1m and must be rounded off to the full meter figure depending on your requirements.

Version/ Plant numbers:

If version or plant numbers are mentioned in the spare parts list, then use the same to check before ordering which spare part needs to be used for your appliance.

Painted parts:

While ordering painted parts that are not mentioned in the spare parts list in their colour variations, please mention the colour number or the colour you require.

Technical changes:

We reserve the right to make technical changes as well as the right to exclusive use of our intellectual property.

FR REMARQUES

Autres langues:

Cette liste de pièces de rechange est disponible en autres langues. Cela est disponible sous www.kaercher.com dans le menu Service. La désignation du numéro de pièce, par ex. 75456380, correspond au numéro de pièce 7.545-638.0.

Indications de quantité:

Les indications de quantité dans la liste de pièces de rechange correspondre aux nombres de pièces des composant utilisées dans la construction.

Matériel au mètre:

Les pièces de rechange qui sont livrées au mètre doivent être raccourcies à longueur souhaitée par l'acheteur même. Les nombres des pièces sont indiquées en quantité de commande minimale = 1m et doivent être augmentés selon le besoin à une chiffre de mètre complète.

Versions/ Numéros d'usine:

Lorsqu'il sont indiquées des versions ou des numéros d'usine dans la liste de pièces de rechange, vous devez vérifier que composant doit être utilisé pour votre appareil.

Pièces laquées:

Pour commander des pièces laquées, où les différentes couleurs ne sont pas indiquées dans la liste des pièces de rechange, vous devez indiquer en plus le numéro de la couleur ou seulement la couleur.

Modifications techniques:

Nous nous réservons la possibilité des modifications techniques ainsi le droit d'exploitation exclusive de notre propriété intellectuelle.

IT AVVERTENZE

Altre lingue:

Il presente elenco di parti di ricambio è disponibile sul nostro sito Web anche in altre lingue: sotto www.kaercher.com alla voce "Service".

L'indicazione del codice pezzo, ad es. 75456380, corrisponde al codice pezzo 7.545-638.0

Indicazioni di quantità:

Le indicazioni di quantità riportate dall'elenco "parti di ricambio" corrispondono al numero delle singole componenti contenute nella rispettiva unità.

Merce a metro:

Le parti di ricambio fornite come "merce a metro" devono venire in seguito accorciate alla lunghezza necessaria per il montaggio. La quantità unitaria è indicata come "quantità minima di ordinazione = 1m" e deve all'occorrenza venire moltiplicata per il numero intero di metri necessari.

Versioni / Numeri di fabbricazione:

Quando l'elenco "parti di ricambio" riporta diverse versioni o numeri di fabbricazione, confrontare la versione o il numero di fabbricazione del ricambio desiderato con quelle/i presenti nell'elenco e indicarla/o al momento dell'ordinazione.

Parti di ricambio verniciate:

Nel caso di ricambi verniciati, se l'elenco parti di ricambio non ne riporta espressamente i diversi colori, al momento dell'ordinazione è necessario indicare anche il colore o il numero del colore desiderato.

Modifiche tecniche:

Ci riserviamo il diritto di apportare modifiche tecniche così come il diritto di utilizzo esclusivo della nostra proprietà intellettuale.

ES INDICACIONES

Otros idiomas:

La lista de piezas de repuesto se puede adquirir en otros idiomas. La puede adquirir en www.kaercher.com en el área de servicios.

La notación de los números de las piezas, p.ej. 75456380 corresponde al número de pieza 7.545-638.0.

Cantidades:

Las indicaciones de cantidades de la lista de piezas de repuesto corresponden al número de piezas montadas en el componente.

Mercancía por metros:

Las piezas de repuesto que se suministran por metros se pueden cortar al largo deseado. La unidad mínima de pedido es de = 1 m y el número de metros completos se puede aumentar según necesidad.

Versiones/números de fábrica:

Si se indica la versión o número de fábrica en la lista de piezas de repuesto, se debe comprobar en ella la pieza a usar para su aparato antes de realizar el pedido.

Piezas lacadas:

Al realizar pedidos de piezas lacadas que no estén indicadas en los diferentes colores en la lista de piezas de repuesto, se debe indicar también la referencia del color o el color.

Modificaciones técnicas:

Reservados los derechos de realizar modificaciones técnicas y aprovechar nuestra propiedad intelectual.

PL WSKAZÓWKI

Pozostałe języki:

Ta lista części zamiennych jest dostępna w także w innych językach. Mogą ją Państwo pobrać ze strony www.kaercher.com w dziale Serwis.

Sposób zapisywania numeru części, np. 75456380, odpowiada numerowi części 7.545-638.0.

Dane ilości:

Dane ilości podane w liście części zamiennych odpowiadają liczbie sztuk podzespołów tworzących dany moduł.

Towar sprzedawany na metry:

Części zamienne dostarczane jako towar sprzedawany na metry po zamontowaniu należy samodzielnie skrócić do potrzebnej długości. Liczba sztuk podana jest jako minimalna ilość zamówienia = 1m i w zależności od potrzeb zwiększa się ją o kolejne pełne metry.

Wersje/ Numer zakładu:

Jeżeli w liście części zamiennych podane są wersje lub numery zakładu, przed zamówieniem na ich podstawie należy sprawdzić, który podzespół stosuje się w Państwa urządzeniu.

Części lakierowane:

W przypadku zamówień części lakierowanych, które w liście części zamiennych nie podano w wielu kolorach, należy dodatkowo zaznaczyć nr koloru lub kolor.

Zmiany techniczne:

Zastrzegamy sobie prawo do zmian technicznych oraz wyłącznego wykorzystywania naszej własności intelektualnej.

RU УКАЗАНИЯ:

Другие языки:

Данный список запасных частей также доступен на других языках. Вы найдете его на сайте www.kaercher.com в разделе Service. Маркировка номера детали, например, 75456380, соответствует номеру детали 7.545-638.0.

Указание количества:

Количественные данные в списке запасных частей соответствуют числу компонентов, входящих в состав узлов.

Товар, продаваемый на метры:

Запасные части, продающиеся на метры, необходимо обрезать до нужной длины. Число изделий указано в виде минимального объема заказа = 1м и их количество можно округлить до требуемого по мере необходимости.

Варианты исполнения/заводские номера:

Если варианты исполнения или заводские номера указаны в списке запасных частей, то перед заказом необходимо проверить, какая деталь подходит для вашего устройства.

Лакированные детали:

При заказе лакированных деталей, варианты расцветки которых не указаны в списке запасных частей, необходимо дополнительно указать номер цвета или необходимый для вас цвет.

Технические изменения:

Мы оставляем за собой право на технические изменения, а также право на исключительное использование нашей интеллектуальной собственности.

Spare parts list HD 830 BS *EU (5.958-795.0)	6
10 Individual parts.....	7
20 Pump set.....	9
21 Valves.....	10
3 Valve (3 Stück) from 2.885-299.0 (2.884-916.0).....	12
4 Spare part (4.132-007.0).....	14
17 Spare part set chemistry (2.883-862.0).....	16
100 Spare parts kit fuer Pumpenersatz (2.884-214.0).....	17
22 Piston.....	18
23 Valves.....	20
1 Spare part set chemistry (2.883-862.0).....	22
2 Nozzle insert only for replacement (4.769-034.0).....	23
12 Valve (3 Stück) from 2.885-299.0 (2.884-916.0).....	25
13 Spare part (4.132-007.0).....	27
24 Piston.....	29
11 Moulded part complete only for replaceme (4.030-069.0).....	31
25 Pump set complete.....	32
30 Motor.....	34
31 Motor.....	35
32 Transmission housing.....	37
200 Tool RPM meter digital.....	39
40 Accessories.....	41
41 Hand trigger gun.....	42
42 Hand trigger gun.....	44
5 level complete (4.481-209.0).....	46
43 Hand trigger gun.....	48
5 level complete (4.481-209.0).....	50
44 Jet pipe.....	52
45 Triple jet nozzle.....	54
46 Nozzle.....	56
0 Triple jet nozzle only for replacement 0 (4.767-150.0).....	58
1 Triple jet nozzle 040.....	59

Spare parts list HD 830 BS *EU (5.958-795.0)

Poz.	Nosaukums	Daudzums	Pārdoš. vienība	no sēr. Nr..	līdz sēr. Nr.
10	Individual parts	1.000	ST	0000000000	0000000000
20	Pump set	1.000	ST	0000000000	0000000000
30	Motor	1.000	ST	0000000000	0000000000
40	Accessories	1.000	ST	0000000000	0000000000

10 Individual parts

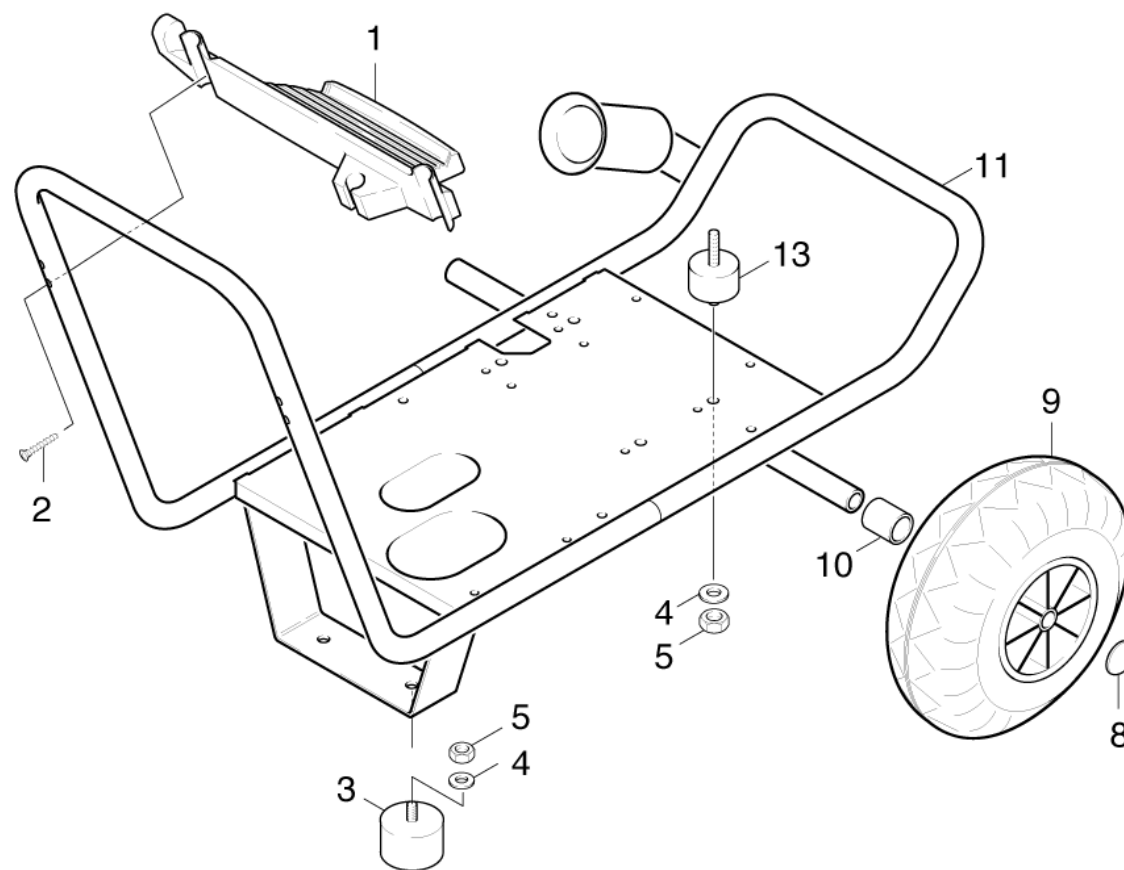

10 Individual parts

Rez.daļas/nodil.pakļ.daļas	Poz.	Materiāla Nr.	Nosaukums	Daudzums	Pārdoš. vienība	no sēr. Nr..	līdz sēr. Nr.
	1	5.321-273.0	Handhold	1.000	ST	0000000000	0000000000
	2	7.303-384.0	Sheet metal screw ST4,8X38,0-ST-A2S IS	2.000	ST	0000000000	0000000000
	3	6.339-025.0	Rubber buffer	2.000	ST	0000000000	0000000000
	4	7.312-004.0	Paplāksne 8 -200HV-A3E ISO 7090	6.000	ST	0000000000	0000000000
	5	7.311-427.0	Hexagon nut M8 -04-A2E ISO 10511	6.000	ST	0000000000	0000000000
X-X	8	6.343-137.0	Ātrais savienotājs	2.000	ST	0000000000	0000000000
X	9	6.435-009.0	Wheel	2.000	ST	0000000000	0000000000
	10	5.110-378.0	Sleeve	2.000	ST	0000000000	0000000000
	11	4.050-392.0	Frame	1.000	ST	0000000000	0000000000
	13	6.339-200.0	Rubber buffer	4.000	ST	0000000000	0000000000

20 Pump set

Poz.	Nosaukums	Daudzums	Pārdoš. vienība	no sēr. Nr..	līdz sēr. Nr.
21	Valves	1.000	ST	0000000000	0000000000
22	Piston	1.000	ST	0000000000	0000000000
23	Valves	1.000	ST	0000000000	0000000000
24	Piston	1.000	ST	0000000000	0000000000
25	Pump set complete	1.000	ST		

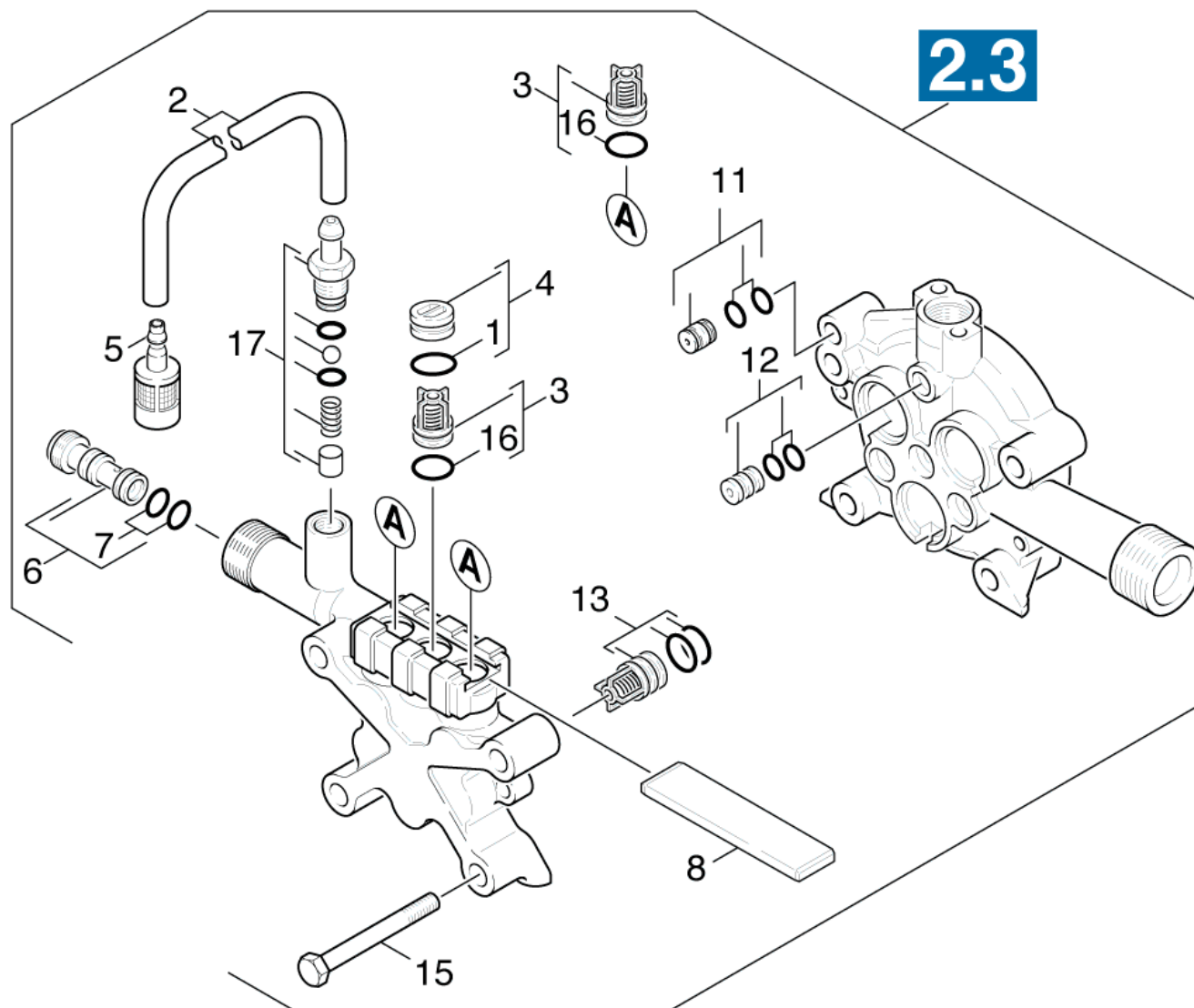

21 Valves

Rez.daļas/nodil.pakļ.daļas	Poz.	Materiāla Nr.	Nosaukums	Daudzums	Pārdoš. vienība	no sēr. Nr..	līdz sēr. Nr.
	1	6.363-273.0	Gredzenblīve 11,0 x 2,0	3.000	ST	0000000000	0000000000
	2	6.388-216.0	Šļūtene DN 5	1.000	M	0000000000	0000000000
X-X	3	2.884-916.0	Valve (3 Stück) from 2.885-299.0	1.000	ST	0000000000	0000000000
X-X	4	4.132-007.0	Spare part	3.000	ST	0000000000	0000000000
	5	4.862-032.0	Filtrās	1.000	ST	0000000000	0000000000
	6	4.769-032.0	nozzle insert	1.000	ST	0000000000	0000000000
	7	6.362-384.0	Gredzenblīve 9x1,5 - NBR 70	2.000	ST	0000000000	0000000000
	8	5.003-062.0	Plate	1.000	ST	0000000000	0000000000
	11	4.030-109.0	Throttle complete	1.000	ST	0000000000	0000000000
	12	4.030-125.0	Joining piece only for replacement	1.000	ST	0000000000	0000000000
X-X	13	4.580-330.0	Suction valve	3.000	ST	0000000000	0000000000
	15	7.304-097.0	Hexagonal head screw M8x70-8.8-A2E ISO	1.000	ST	0000000000	0000000000
	16	6.362-077.0	Gredzenblīve 10 x 2,2 NBR 70	3.000	ST	0000000000	0000000000
	17	2.883-862.0	Spare part set chemistry	1.000	ST	0000000000	0000000000
	100	2.884-214.0	Spare parts kit fuer Pumpenersatz	1.000	ST	0000000000	0000000000

3 Valve (3 Stück) from 2.885-299.0 (2.884-916.0)

Poz.	Materiāla Nr.	Nosaukums	Daudzums	Pārdoš. vienība
15	6.362-077.0	Gredzenblīve 10 x 2,2 NBR 70	1.000	ST

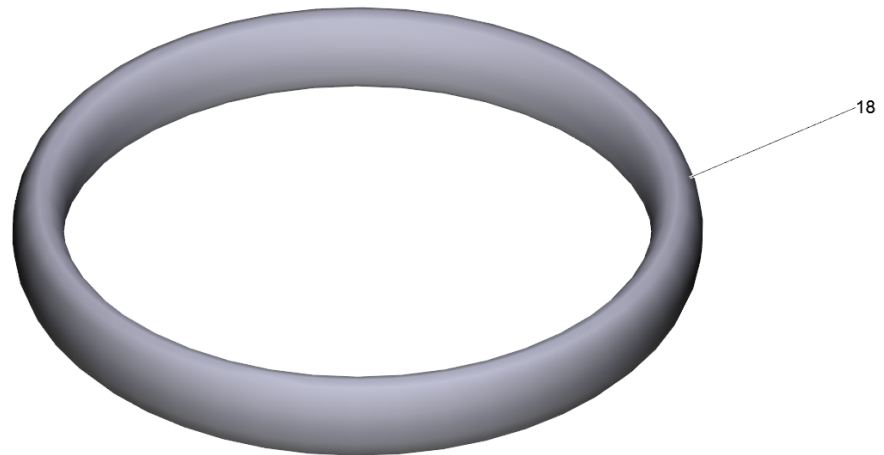
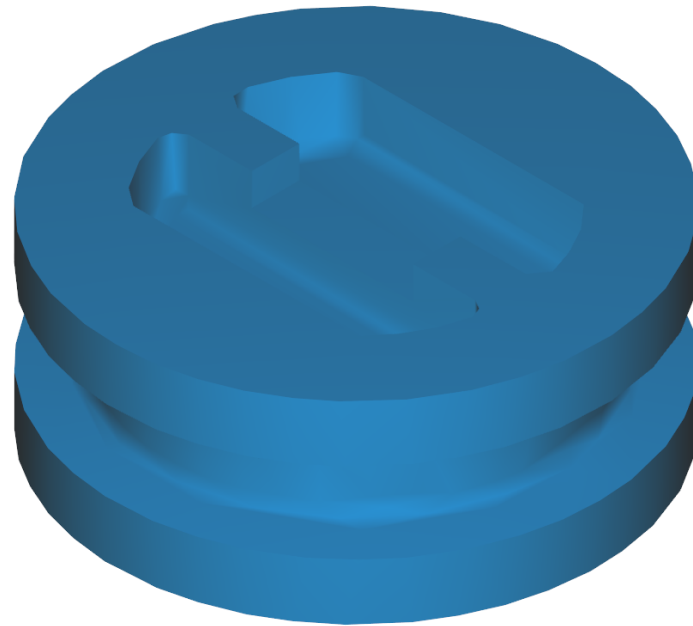

4 Spare part (4.132-007.0)

Poz.	Materiāla Nr.	Nosaukums	Daudzums	Pārdoš. vienība
18	6.362-458.0	Gredzenblīve 11,0x2,0-NBR 70	1.000	ST

17 Spare part set chemistry (2.883-862.0)

Poz.	Materiāla Nr.	Nosaukums	Daudzums	Pārdoš. vienība	no sēr. Nr..	līdz sēr. Nr.
10	5.110-714.0	Uzmava	1.000	ST	0000000000	0000000000
20	5.332-258.0	Spirālveida atspere	1.000	ST	0000000000	0000000000
30	5.380-014.0	Label	1.000	ST	0000000000	0000000000
40	5.443-448.0	Nipple chemistry	1.000	ST	0000000000	0000000000
50	6.362-175.0	Gredzenblīve 5,28x 1,78	1.000	ST	0000000000	0000000000
60	6.362-451.0	O-Ring seal 8,0 x 1,0	1.000	ST	0000000000	0000000000
70	7.401-909.0	Sphere	1.000	ST	0000000000	0000000000

100 Spare parts kit fuer Pumpenersatz (2.884-214.0)

Rez.daļas/nodil.pakļ.dajas	Poz.	Materiāla Nr.	Nosaukums	Daudzums	Pārdoš. vienība	no sēr. Nr..	līdz sēr. Nr.
	10	4.030-045.0	Joining piece only for replacement	1.000	ST	0000000000	0000000000
	20	4.030-109.0	Throttle complete	1.000	ST	0000000000	0000000000
X-X	30	4.580-330.0	Suction valve	3.000	ST	0000000000	0000000000
	40	4.580-331.0	Valve complete	3.000	ST	0000000000	0000000000
	50	4.591-036.0	Excess-current complete	1.000	ST	0000000000	0000000000
	60	5.110-707.0	Uzmava	3.000	ST	0000000000	0000000000
	70	5.115-720.0	Washer	3.000	ST	0000000000	0000000000
X-X	80	5.115-721.0	Paplāksne	3.000	ST	0000000000	0000000000
	90	6.362-384.0	Gredzenblīve 9x1,5 - NBR 70	2.000	ST	0000000000	0000000000
	100	6.362-458.0	Gredzenblīve 11,0x2,0-NBR 70	3.000	ST	0000000000	0000000000
	110	6.362-471.0	Gredzenblīve 80,0 X 3,0 -NBR 70	1.000	ST	0000000000	0000000000
	120	6.362-851.0	Gredzenblīve 4 x 2 NBR 90	1.000	ST	0000000000	0000000000
	130	6.365-393.0	Gredzens ar rievu 12x20x4/6	3.000	ST	0000000000	0000000000
X-X	140	6.365-394.0	Gredzens ar gropi 12x20x5,3/2,8	3.000	ST	0000000000	0000000000

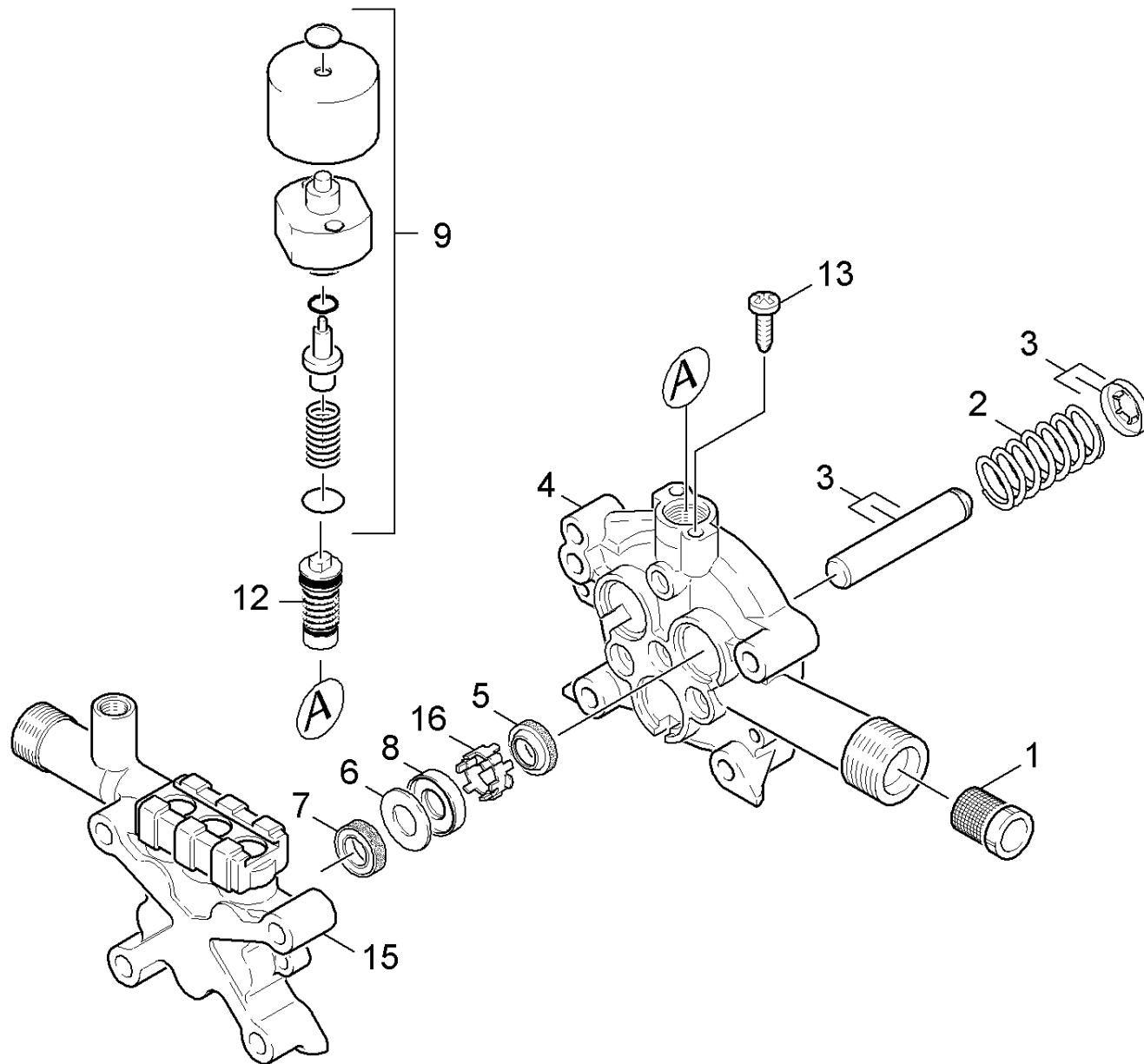

22 Piston

Rez.daļas/nodil.pakļ.daļas	Poz.	Materiāla Nr.	Nosaukums	Daudzums	Pārdoš. vienība	no sēr. Nr..	līdz sēr. Nr.
	1	6.414-252.0	Sieta filtrs	1.000	ST	0000000000	0000000000
	2	5.332-391.0	Piespiedējatšpere	3.000	ST	0000000000	0000000000
	3	4.553-173.0	Piston complete	3.000	ST	0000000000	0000000000
	4	5.060-642.0	Virzuļa vadotne	1.000	ST	0000000000	0000000000
	5	6.365-393.0	Gredzens ar rievu 12x20x4/6	3.000	ST	0000000000	0000000000
X-X	6	5.115-721.0	Paplāksne	3.000	ST	0000000000	0000000000
X-X	7	6.365-394.0	Gredzens ar gropi 12x20x5,3/2,8	3.000	ST	0000000000	0000000000
	8	5.115-720.0	Washer	3.000	ST	0000000000	0000000000
	9	4.580-359.0	Therموvalve	1.000	ST	0000000000	0000000000
	12	4.591-040.0	Spill valve complete	1.000	ST	0000000000	0000000000
	13	7.303-066.0	Screw M6x30 -St-R3R (In6Rd)	2.000	ST	0000000000	0000000000
	15	5.550-294.0	Cilindra galva	1.000	ST	0000000000	0000000000
	16	5.110-707.0	Uzmava	3.000	ST	0000000000	0000000000

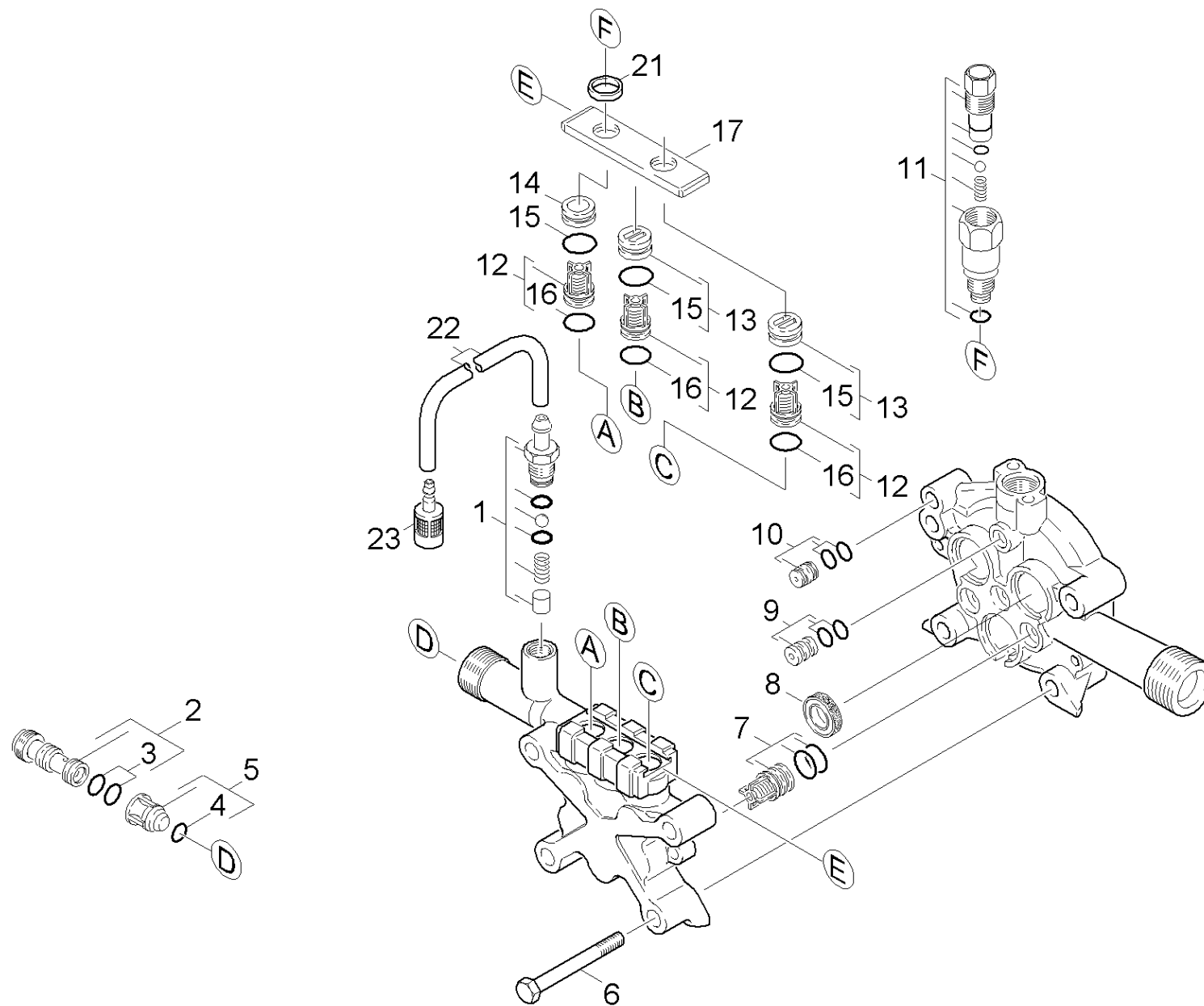

23 Valves

Rez.daļas/nodil.pakļ.daļas	Poz.	Materiāla Nr.	Nosaukums	Daudzums	Pārdoš. vienība	no sēr. Nr..	līdz sēr. Nr.
	1	2.883-862.0	Spare part set chemistry	1.000	ST	0000000000	0000000000
	2	4.769-034.0	Nozzle insert only for replacement	1.000	ST	0000000000	0000000000
	3	6.362-384.0	Gredzenblīve 9x1,5 - NBR 70	2.000	ST	0000000000	0000000000
X	4	6.363-613.0	Gredzenblīve 4 x 2 -NBR90	1.000	ST	0000000000	0000000000
	5	5.584-091.0	Pretvārsta ass	1.000	ST	0000000000	0000000000
	6	7.304-097.0	Hexagonal head screw M8x70-8.8-A2E ISO	1.000	ST	0000000000	0000000000
X-X	7	4.580-330.0	Suction valve	3.000	ST	0000000000	0000000000
X-X	8	6.365-394.0	Gredzens ar gropi 12x20x5,3/2,8	3.000	ST	0000000000	0000000000
	9	4.030-125.0	Joining piece only for replacement	1.000	ST	0000000000	0000000000
	10	4.030-070.0	Throttle complete	1.000	ST	0000000000	0000000000
X	11	4.580-348.0	Therموvalve	1.000	ST	0000000000	0000000000
X-X	12	2.884-916.0	Valve (3 Stück) from 2.885-299.0	1.000	ST	0000000000	0000000000
X-X	13	4.132-007.0	Spare part	1.000	ST	0000000000	0000000000
X-X	14	4.132-013.0	DRAIN PLUG	1.000	ST	0000000000	0000000000
	15	6.363-273.0	Gredzenblīve 11,0 x 2,0	3.000	ST	0000000000	0000000000
	16	6.362-077.0	Gredzenblīve 10 x 2,2 NBR 70	3.000	ST	0000000000	0000000000
	17	5.006-049.0	Plate	1.000	ST	0000000000	0000000000
X-X	21	5.115-799.0	Washer	1.000	ST	0000000000	0000000000
	22	6.388-216.0	Šļūtene DN 5	1.000	M	0000000000	0000000000
	23	9.181-001.0	Strainer	1.000	ST	0000000000	0000000000

1 Spare part set chemistry (2.883-862.0)

Poz.	Materiāla Nr.	Nosaukums	Daudzums	Pārdoš. vienība	no sēr. Nr..	līdz sēr. Nr.
10	5.110-714.0	Uzmava	1.000	ST	0000000000	0000000000
20	5.332-258.0	Spirālveida atspere	1.000	ST	0000000000	0000000000
30	5.380-014.0	Label	1.000	ST	0000000000	0000000000
40	5.443-448.0	Nipple chemistry	1.000	ST	0000000000	0000000000
50	6.362-175.0	Gredzenblīve 5,28x 1,78	1.000	ST	0000000000	0000000000
60	6.362-451.0	O-Ring seal 8,0 x 1,0	1.000	ST	0000000000	0000000000
70	7.401-909.0	Sphere	1.000	ST	0000000000	0000000000

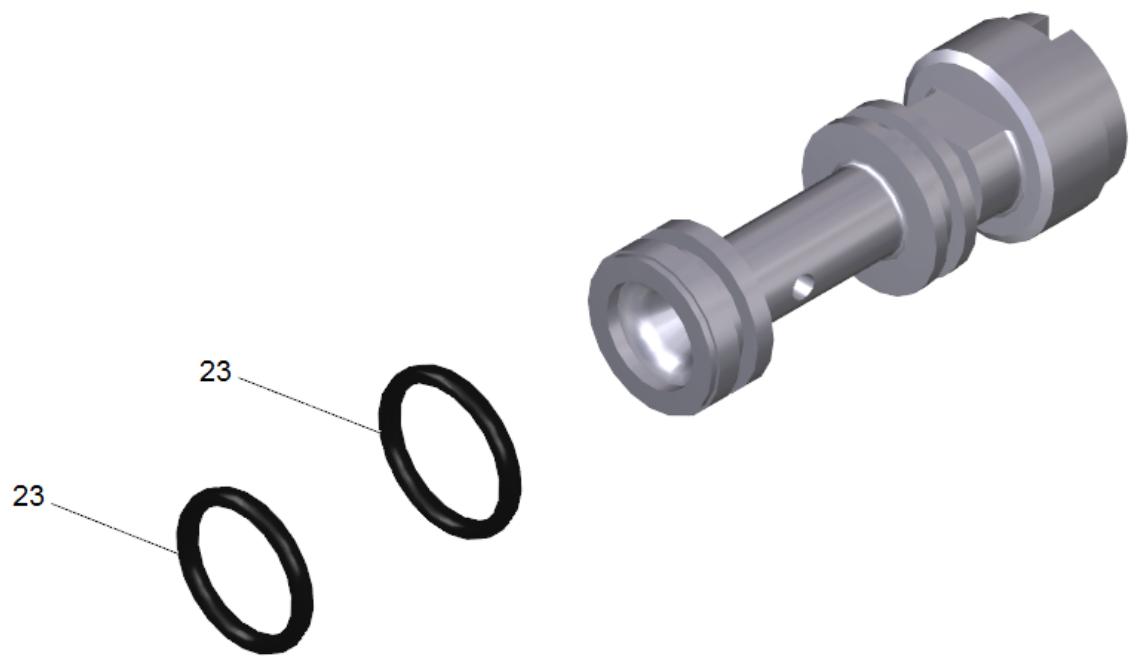

2 Nozzle insert only for replacement (4.769-034.0)

Poz.	Materiāla Nr.	Nosaukums	Daudzums	Pārdoš. vienība
23	6.362-384.0	Gredzenblīve 9x1,5 - NBR 70	2.000	ST

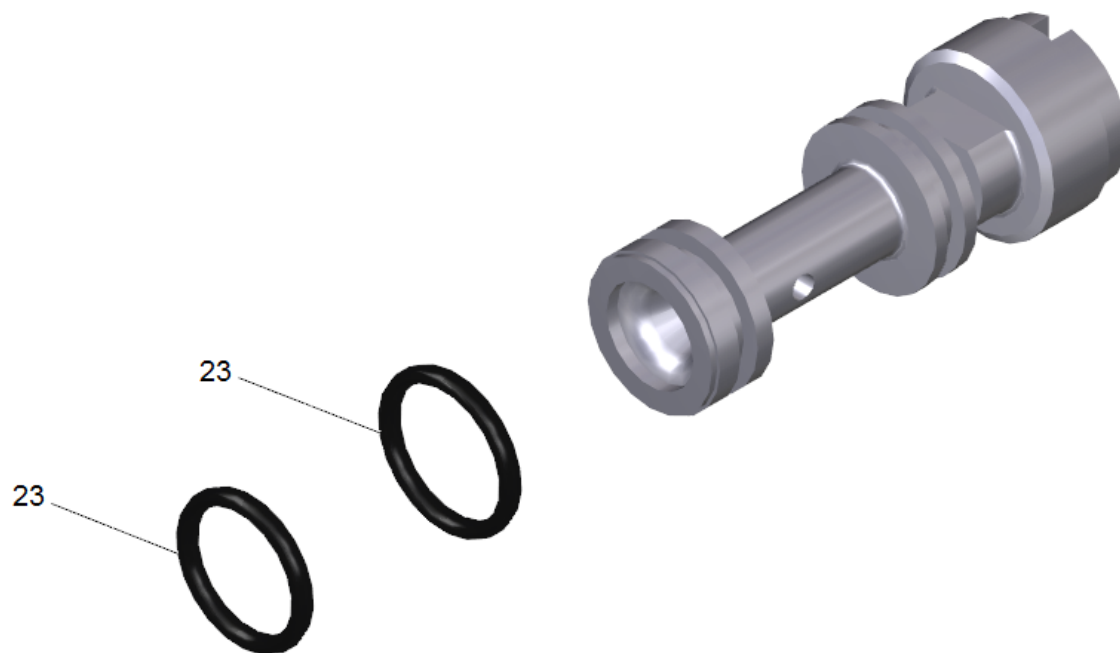

12 Valve (3 Stück) from 2.885-299.0 (2.884-916.0)

Poz.	Materiāla Nr.	Nosaukums	Daudzums	Pārdoš. vienība
15	6.362-077.0	Gredzenblīve 10 x 2,2 NBR 70	1.000	ST

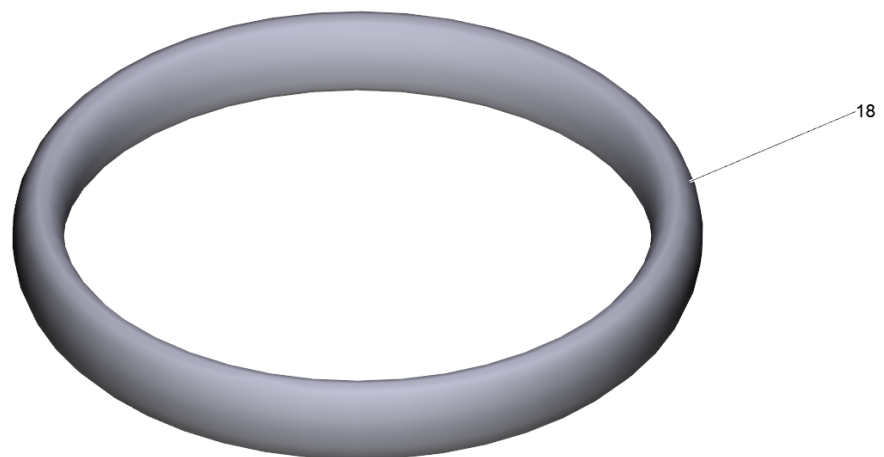
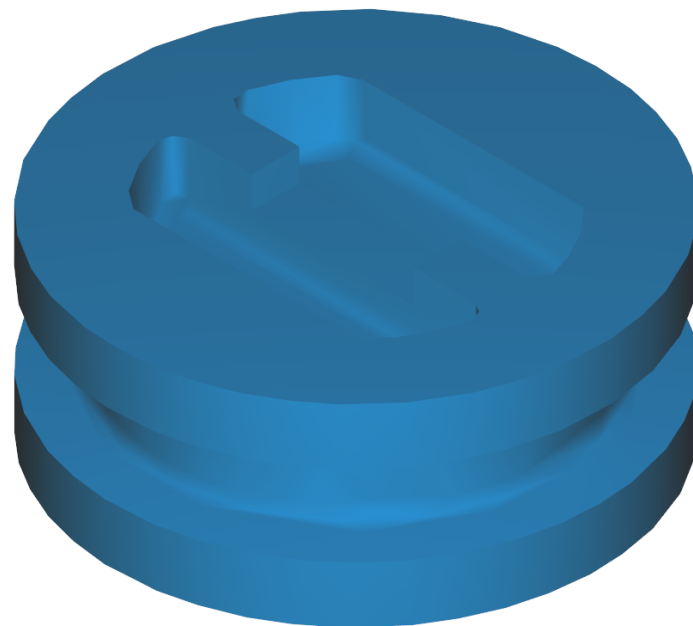

13 Spare part (4.132-007.0)

Poz.	Materiāla Nr.	Nosaukums	Daudzums	Pārdoš. vienība
18	6.362-458.0	Gredzenblīve 11,0x2,0-NBR 70	1.000	ST

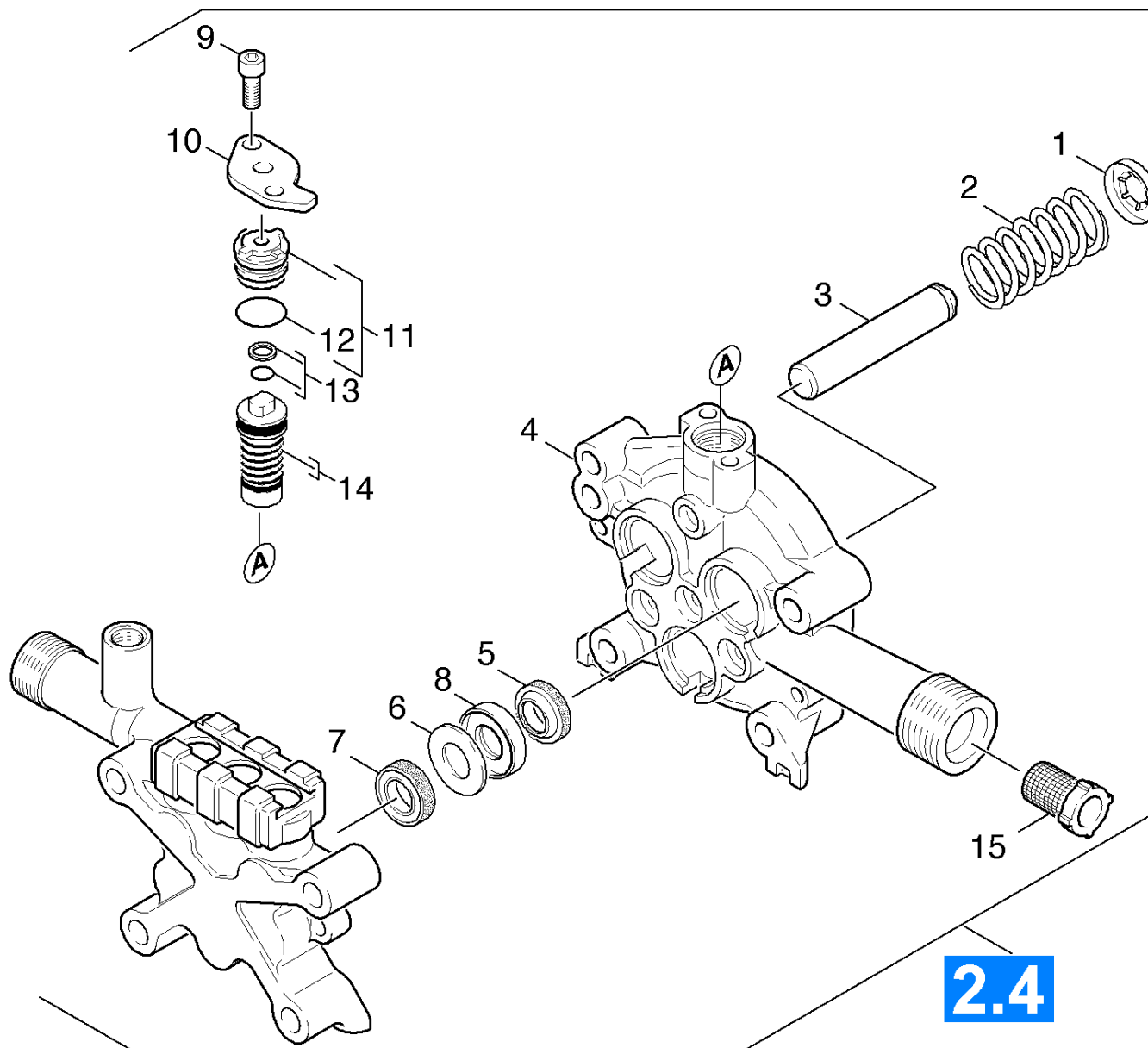

24 Piston

Rez.daļas/nodil.pakļ.daļas	Poz.	Materiāla Nr.	Nosaukums	Daudzums	Pārdoš. vienība	no sēr. Nr..	līdz sēr. Nr.
X-X	1	5.115-671.0	Lock washer	1.000	ST	0000000000	0000000000
X-X	2	5.332-437.0	Pressure spring	3.000	ST	0000000000	0000000000
	3	4.553-173.0	Piston complete	3.000	ST	0000000000	0000000000
	4	4.060-820.0	Piston	1.000	ST	0000000000	0000000000
X-X	5	6.365-414.0	Gredzens ar gropi 12X20X5/6	3.000	ST	0000000000	0000000000
X-X	6	5.115-721.0	Paplāksne	3.000	ST	0000000000	0000000000
X-X	7	6.365-394.0	Gredzens ar gropi 12x20x5,3/2,8	3.000	ST	0000000000	0000000000
	8	5.115-720.0	Washer	3.000	ST	0000000000	0000000000
	9	7.306-090.0	Screw M6x16 -8.8-R3R (In6Rd)	2.000	ST	0000000000	0000000000
	10	5.064-127.0	Cover	1.000	ST	0000000000	0000000000
	11	4.030-069.0	Moulded part complete only for replaceme	1.000	ST	0000000000	0000000000
	12	6.362-169.0	Gredzenblīve 12,0 X 2,0	1.000	ST	0000000000	0000000000
X-X	13	6.362-575.0	Gredzenblīve 12,42 KOMPL	1.000	ST	0000000000	0000000000
X-X	14	4.591-037.0	valve fort replacement	1.000	ST	0000000000	0000000000
	15	6.414-252.0	Sieta filtrs	1.000	ST	0000000000	0000000000

11 Moulded part complete only for replaceme (4.030-069.0)

Poz.	Materiāla Nr.	Nosaukums	Daudzums	Pārdoš. vienība
94	6.362-169.0	Gredzenblīve 12,0 X 2,0	1.000	ST

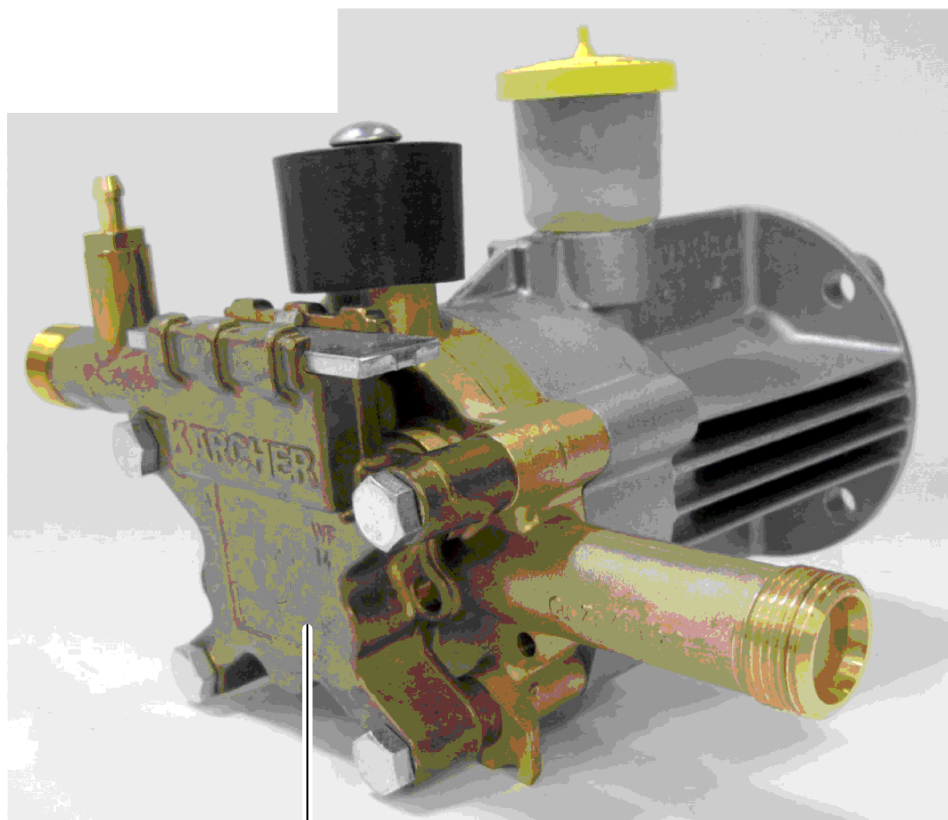

0

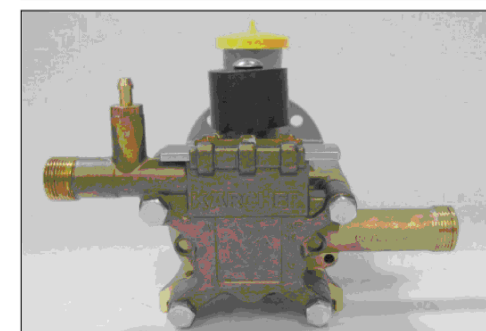
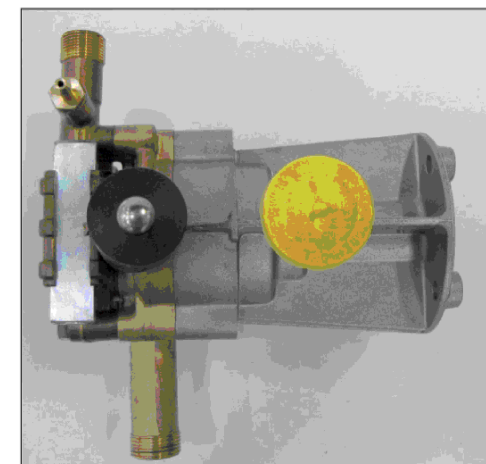
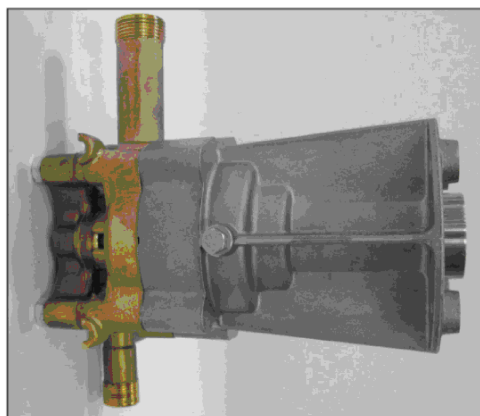

25 Pump set complete

Materiāla Nr.	Nosaukums	Daudzums	Pārdoš. vienība
3.532-684.0	Pump set HD 830 B	1.000	ST

30 Motor

Poz.	Nosaukums	Daudzums	Pārdoš. vienība	no sēr. Nr..	līdz sēr. Nr.
31	Motor	1.000	ST	0000000000	0000000000
32	Transmission housing	1.000	ST	0000000000	0000000000
200	Tool RPM meter digital	1.000	ST		

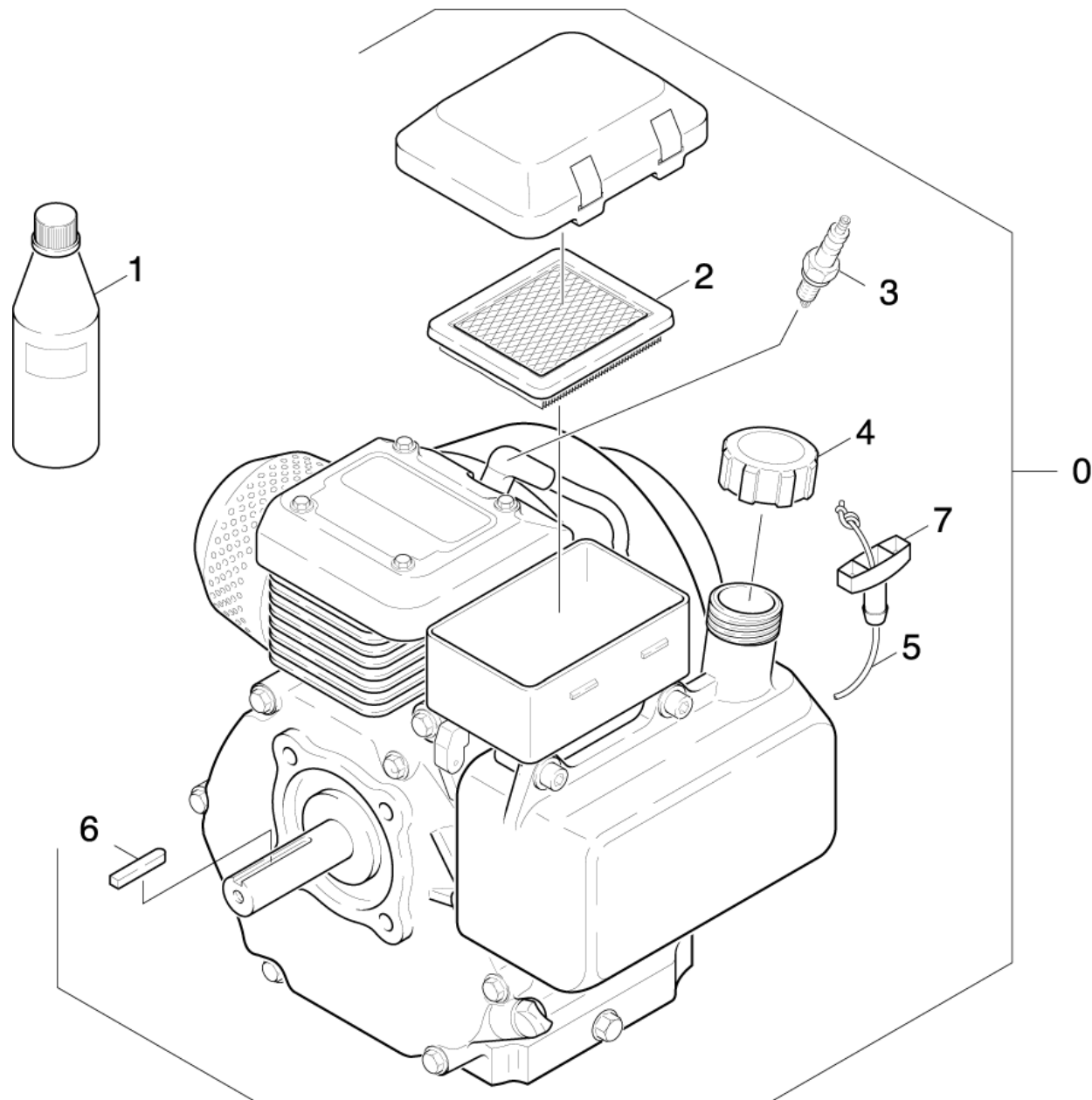

31 Motor

Poz.	Materiāla Nr.	Nosaukums	Daudzums	Pārdoš. vienība	no sēr. Nr..	līdz sēr. Nr.
0	6.491-718.0	Motor 5,0HP HONDA	1.000	ST	0000000000	0000000000
1	6.288-050.0	Transmisijas eļļa 1 l	1.000	ST	0000000000	0000000000
2	6.491-726.0	Filter	1.000	ST	0000000000	0000000000
3	6.491-550.0	Ignition plug BPR6ES	1.000	ST	0000000000	0000000000
4	6.491-723.0	Cap of a tank	1.000	ST	0000000000	0000000000
5	6.491-715.0	Pull cord GCV135 28462-ZL8-003	1.000	ST	0000000000	0000000000
6	6.491-614.0	Parallel key	1.000	ST	0000000000	0000000000
7	6.491-503.0	Handhold	1.000	ST	0000000000	0000000000

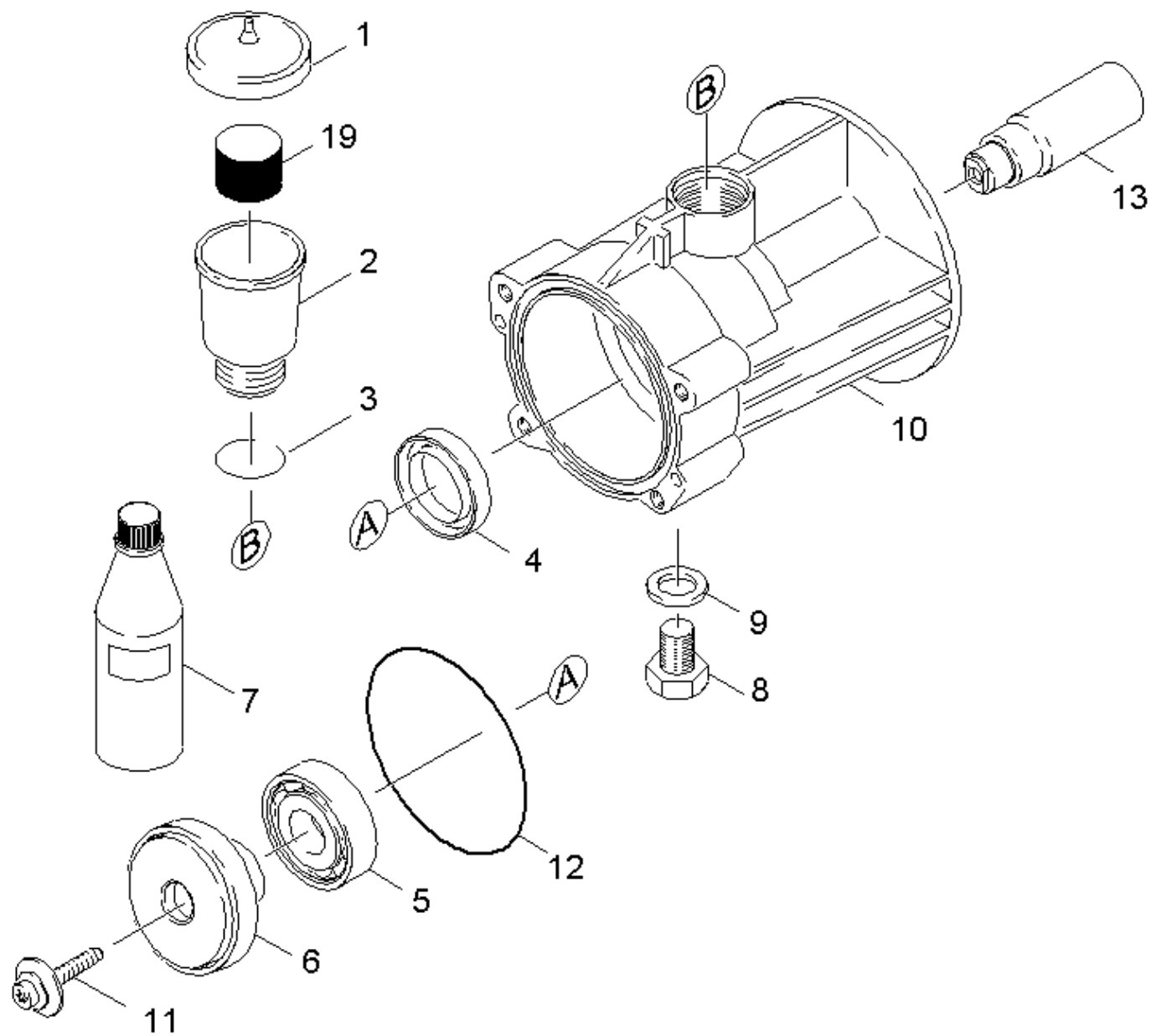

32 Transmission housing

Rez.daļas/nodil.pakļ.dājas	Poz.	Materiāla Nr.	Nosaukums	Daudzums	Pārdoš. vienība	no sēr. Nr..	līdz sēr. Nr.
X-X	1	5.063-651.0	Cover	1.000	ST	0000000000	0000000000
	2	5.070-194.0	Tank	1.000	ST	0000000000	0000000000
	3	6.362-168.0	o ring seal	1.000	ST	0000000000	0000000000
	4	7.367-018.0	Vārpstas blīvslēgs A26x37x7 -NBR DI	1.000	ST	0000000000	0000000000
	5	6.401-427.0	Angular contact ball bearing	1.000	ST	0000000000	0000000000
	6	6.401-289.0	Wobble plate	1.000	ST	0000000000	0000000000
	7	6.288-050.0	Transmisijas eļļa 1 l	1.000	ST	0000000000	0000000000
	8	7.382-085.0	Screw plug M10x1-St-A2E DIN 910	1.000	ST	0000000000	0000000000
	9	7.362-003.0	Blīvgredzens A10x13,5 -Cu DIN 7603	1.000	ST	0000000000	0000000000
	10	4.060-813.0	Housing with sleeve	1.000	ST	0000000000	0000000000
	11	6.304-048.0	Cylinder head screw M6x19	4.000	ST	0000000000	0000000000
	12	6.362-471.0	Gredzenblīve 80,0 X 3,0 -NBR 70	1.000	ST	0000000000	0000000000
	13	5.471-088.0	Coupling element horizontal	1.000	ST	0000000000	0000000000
	19	5.132-107.0	Plug	1.000	ST	0000000000	0000000000

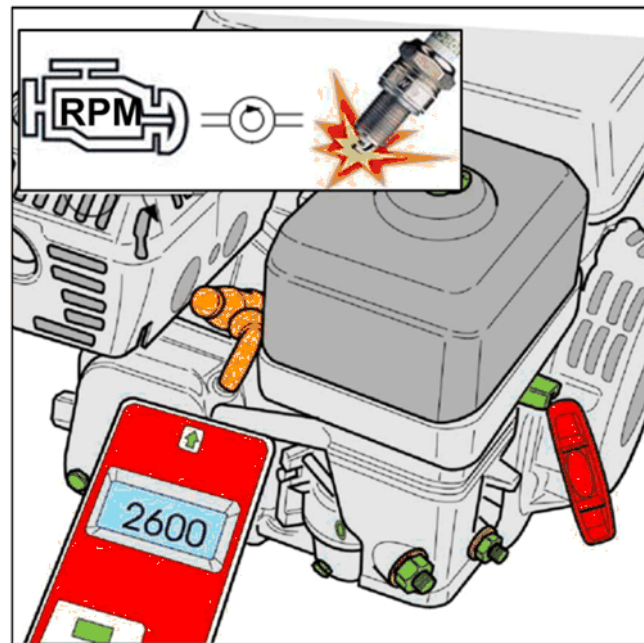
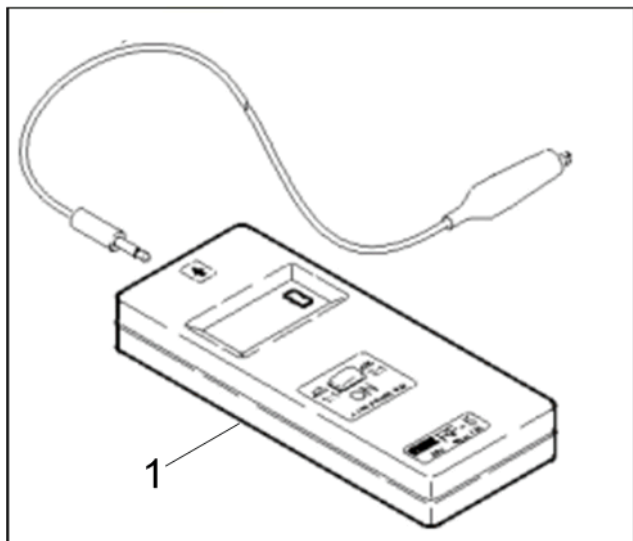

200 Tool RPM meter digital

Poz.	Materiāla Nr.	Nosaukums	Daudzums	Pārdoš. vienība
1	6.803-012.0	RPM Meter digital	1.000	ST

40 Accessories

Poz.	Nosaukums	Daudzums	Pārdoš. vienība	no sēr. Nr.	līdz sēr. Nr.	Daž. informācija
41	Hand trigger gun	1.000	ST	0000000000	0000000000	VERSION 1
42	Hand trigger gun	1.000	ST			VERSION 2
43	Hand trigger gun	1.000	ST			VERSION 3
44	Jet pipe	1.000	ST	0000000000	0000000000	
45	Triple jet nozzle	1.000	ST	0000000000	0000000000	VERSION 1
46	Nozzle	1.000	ST			VERSION 2

41 Hand trigger gun

Poz.	Materiāla Nr.	Nosaukums	Daudzums	Pārdoš. vienība	no sēr. Nr..	līdz sēr. Nr.
0		Stockpiling discontinued	1.000	ST	0000000000	0000000000
1	7.303-096.0	Skrūve 4x22 -ST-10.9-R2R (IN6RD)	1.000	ST	0000000000	0000000000
2	5.321-206.0	Tureklis	1.000	ST	0000000000	0000000000
3	5.322-083.0	Handhold few extended Low End	1.000	ST	0000000000	0000000000
4	6.303-025.0	Oval head screw 4,2x16-St-vz	7.000	ST	0000000000	0000000000
6	5.481-052.0	Lever	1.000	ST	0000000000	0000000000
7	7.307-417.0	Tapa ar vītņi M8x16 -45H-A2E ISO 4026	1.000	ST	0000000000	0000000000
8	4.481-050.0	Lever	1.000	ST	0000000000	0000000000
9	5.411-067.0	Screw plug	1.000	ST	0000000000	0000000000
10	6.362-584.0	Gredzenblīve 12,42X 1,78	1.000	ST	0000000000	0000000000
11	5.332-157.0	Spirālveida atspere	1.000	ST	0000000000	0000000000
12	5.582-058.0	Vārstu plate	1.000	ST	0000000000	0000000000
13	5.107-259.0	Stienis	1.000	ST	0000000000	0000000000
14	6.362-571.0	Gredzenblīve, pilns komplekts 1ST.-R.	1.000	ST	0000000000	0000000000
15	4.427-179.0	Manifold	1.000	ST	0000000000	0000000000
16	5.031-259.0	Moulded part	1.000	ST	0000000000	0000000000
17	6.389-853.0	Augstspiediena šūtene DN6 10m	1.000	ST	0000000000	0000000000
18	2.880-990.0	spare part set o ring from 2.880-296.0	1.000	ST	0000000000	0000000000
19	6.363-115.0	Gredzenblīve, pilns komplekts 1ST.-R.	1.000	ST	0000000000	0000000000

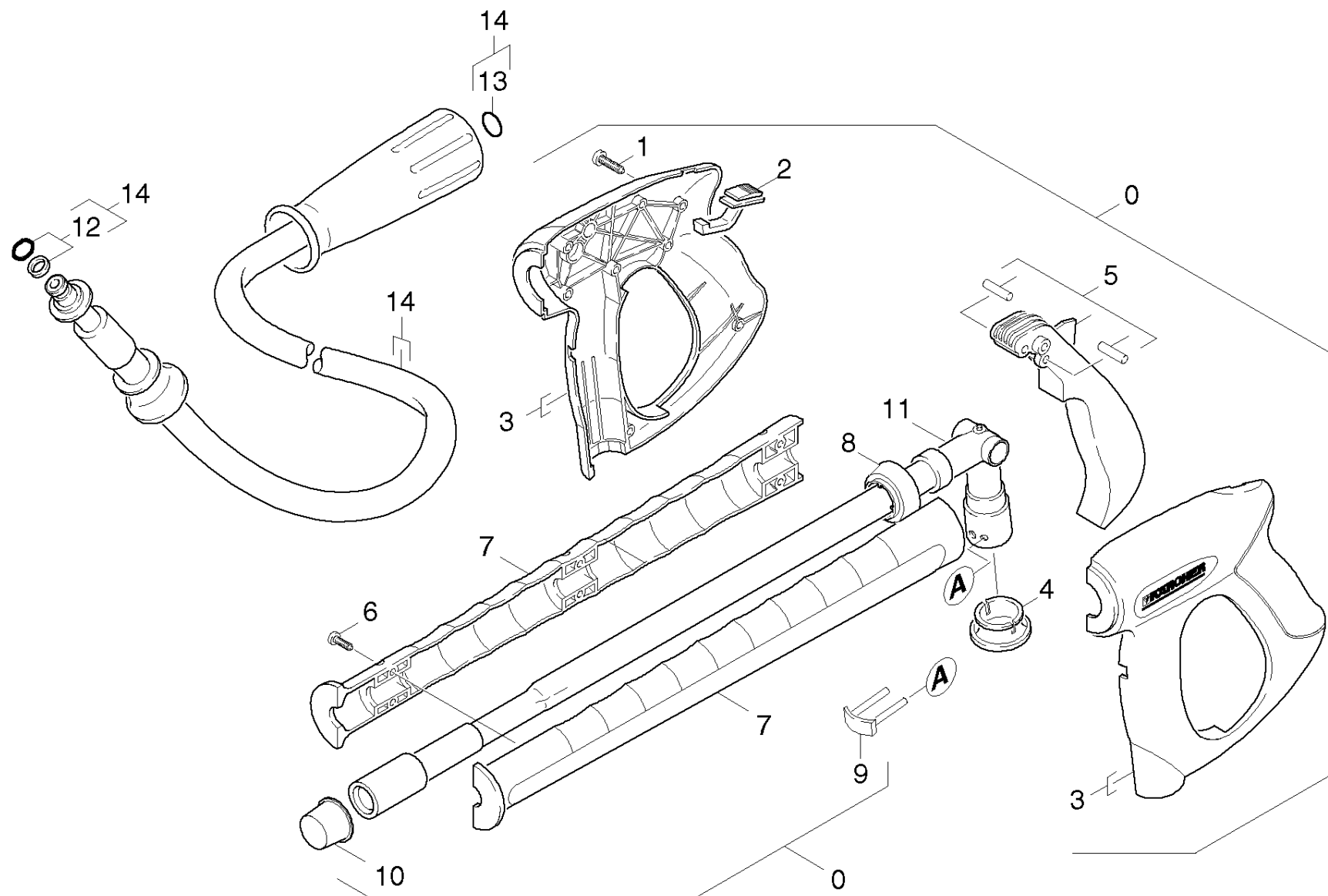

42 Hand trigger gun

Rez.daļas/nodil.pakļ.daļas	Poz.	Materiāla Nr.	Nosaukums	Daudzums	Pārdoš. vienība
X	0	4.775-554.0	Hand trigger gun Low End Nippel 10	1.000	ST
	1	7.303-096.0	Skrūve 4x22 -ST-10.9-R2R (IN6RD)	7.000	ST
	2	5.481-331.0	Slīdnis	1.000	ST
	3	5.322-082.0	Handhold few hand trigger gun Low End	1.000	ST
	4	5.110-596.0	Uzmava	1.000	ST
	5	4.481-209.0	level complete	1.000	ST
	6	7.303-129.0	Skrūve 4x16 -10.9-R2R (K-In6Rd)	6.000	ST
	7	5.322-083.0	Handhold few extended Low End	1.000	ST
	8	5.032-801.0	Moulded part	1.000	ST
	9	4.037-013.0	Spare part	1.000	ST
	10	6.368-012.0	Protecting cap 22X1,5	1.000	ST
	11	4.427-004.0	Manifold complete for replacement LowEnd	1.000	ST
	12	6.363-115.0	Gredzenblīve, pilns komplekts 1ST.-R.	1.000	ST
	13	2.880-990.0	spare part set o ring from 2.880-296.0	1.000	ST
	14	6.389-853.0	Augstspiediena šļūtene DN6 10m	1.000	ST

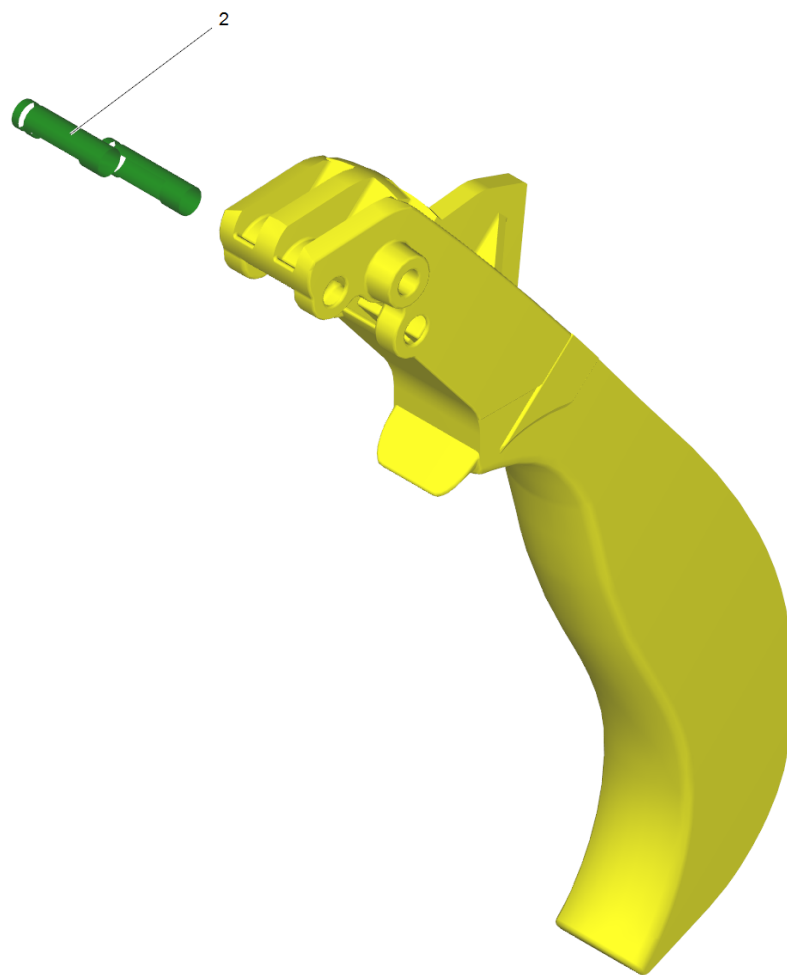

5 level complete (4.481-209.0)

Poz.	Materiāla Nr.	Nosaukums	Daudzums	Pārdoš. vienība
2	5.314-119.0	Pin	2.000	ST

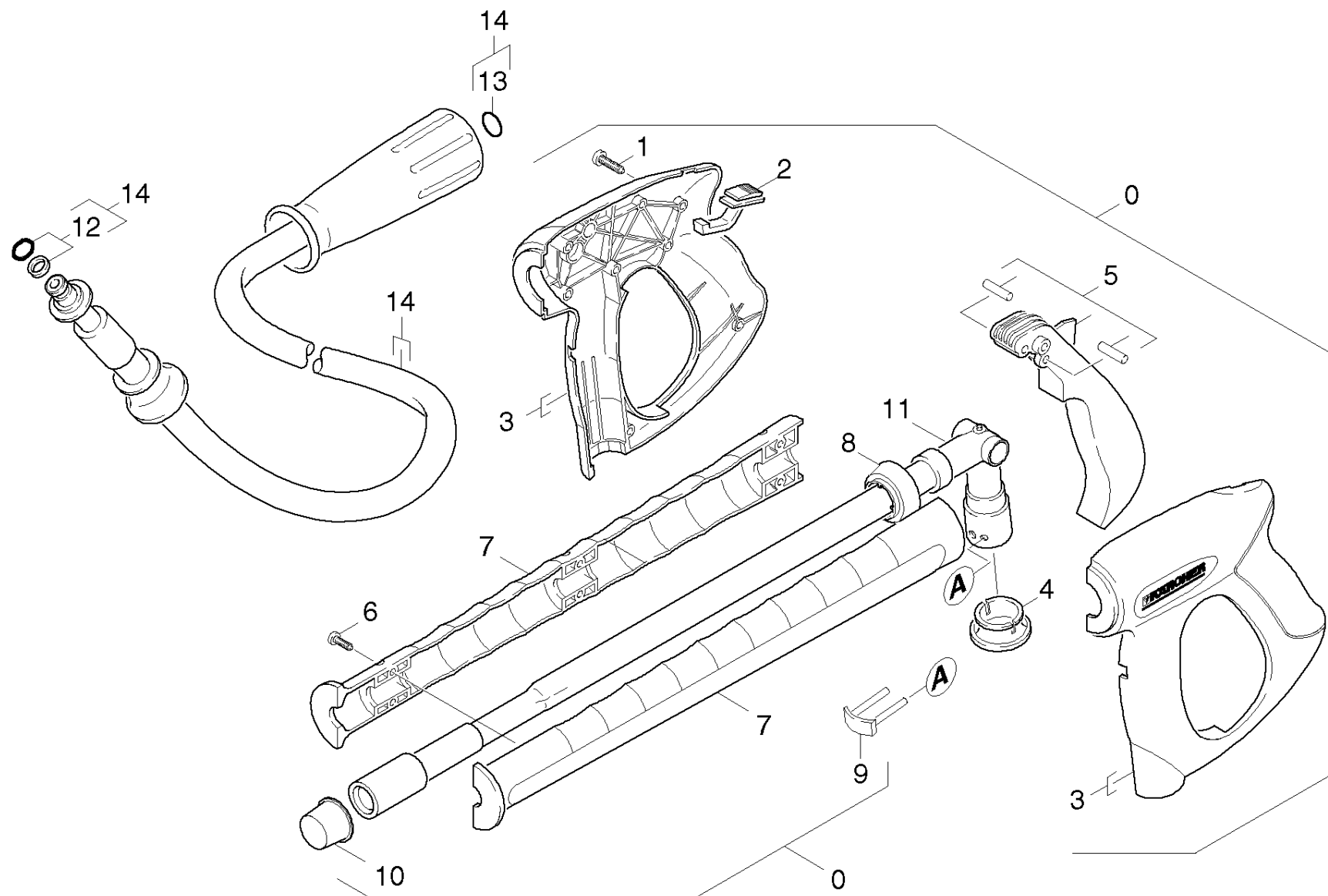

43 Hand trigger gun

Rez.daļas/nodil.pakļ.daļas	Poz.	Materiāla Nr.	Nosaukums	Daudzums	Pārdoš. vienība	no sēr. Nr..	līdz sēr. Nr.
	0	4.775-529.0	Trigger gun	1.000	ST	0000000000	0000000000
	1	7.303-096.0	Skrūve 4x22 -ST-10.9-R2R (IN6RD)	7.000	ST	0000000000	0000000000
	2	5.481-331.0	Slīdnis	1.000	ST	0000000000	0000000000
	3	5.322-082.0	Handhold few hand trigger gun Low End	1.000	ST	0000000000	0000000000
	4	5.110-596.0	Uzmava	1.000	ST	0000000000	0000000000
	5	4.481-209.0	level complete	1.000	ST	0000000000	0000000000
	6	7.303-129.0	Skrūve 4x16 -10.9-R2R (K-In6Rd)	6.000	ST	0000000000	0000000000
	7	5.322-083.0	Handhold few extended Low End	1.000	ST	0000000000	0000000000
	8	5.032-801.0	Moulded part	1.000	ST	0000000000	0000000000
	9	4.037-013.0	Spare part	1.000	ST	0000000000	0000000000
	10	6.368-012.0	Protecting cap 22X1,5	1.000	ST	0000000000	0000000000
X	11	4.427-363.0	Manifol complete only for replacement	1.000	ST	0000000000	0000000000
X-X	12	4.363-691.0	O-ring seal	1.000	ST		
	13	2.880-990.0	spare part set o ring from 2.880-296.0	1.000	ST		
X-X	14	6.391-238.0	Standarta šļūtene DN6 25 MPa 10 m	1.000	ST		

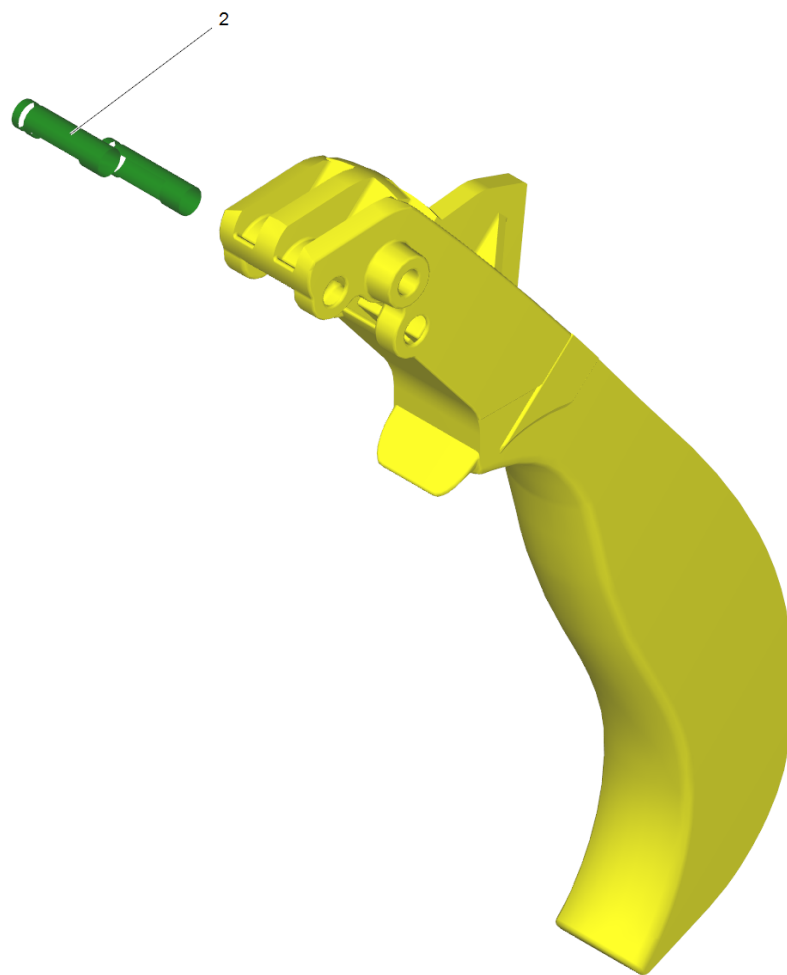

5 level complete (4.481-209.0)

Poz.	Materiāla Nr.	Nosaukums	Daudzums	Pārdoš. vienība
2	5.314-119.0	Pin	2.000	ST

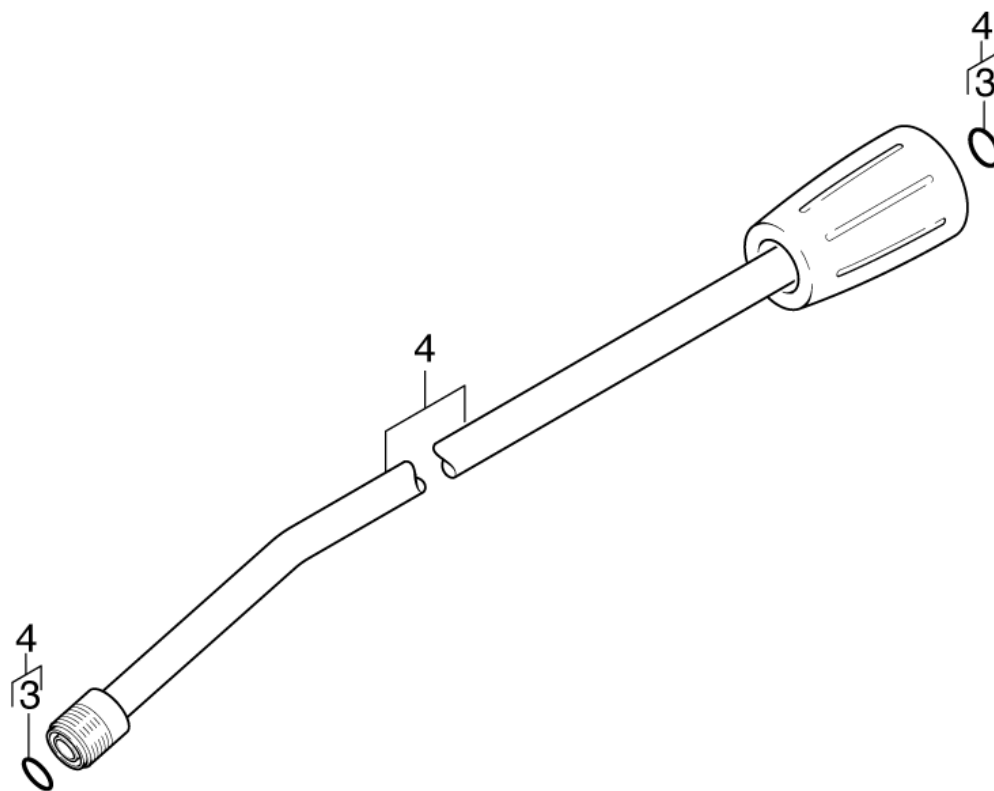

44 Jet pipe

Poz.	Materiāla Nr.	Nosaukums	Daudzums	Pārdoš. vienība	no sēr. Nr..	līdz sēr. Nr.
3	2.880-990.0	spare part set o ring from 2.880-296.0	1.000	ST	0000000000	0000000000
4	4.760-665.0	Jet pipe packaged only for replacement	1.000	ST	0000000000	0000000000

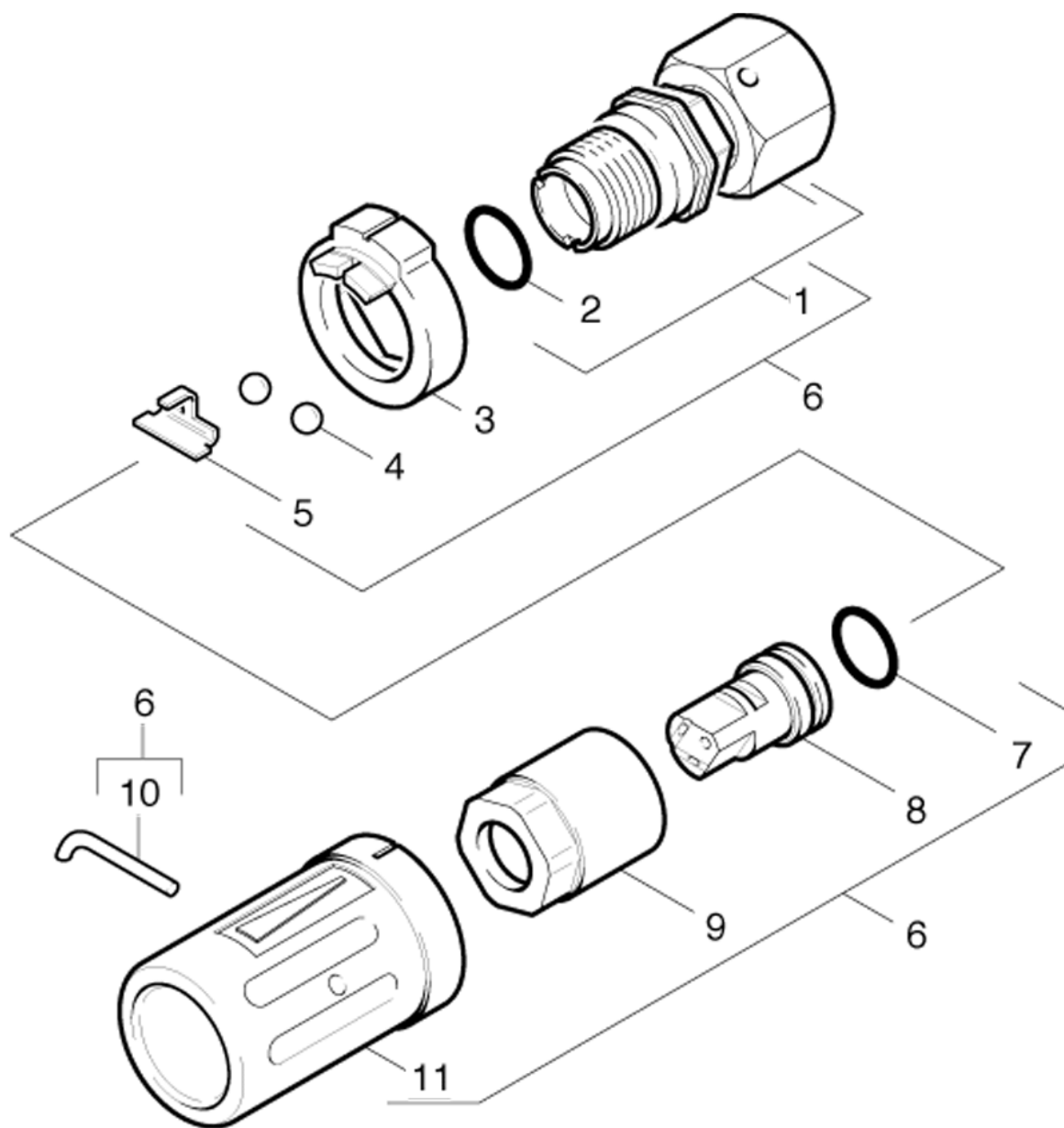

45 Triple jet nozzle

Poz.	Materiāla Nr.	Nosaukums	Daudzums	Pārdoš. vienība	no sēr. Nr..	līdz sēr. Nr.
1	4.402-042.0	Screw union	1.000	ST	0000000000	0000000000
2	6.362-460.0	Gredzenblīve 14,0 X 2,5-NBR 70	1.000	ST	0000000000	0000000000
3	5.030-528.0	Spare part	1.000	ST	0000000000	0000000000
4	7.401-902.0	Sfēra 5 G20 -1.4034 DIN 5401	2.000	ST	0000000000	0000000000
5	5.042-405.0	Turētājs	1.000	ST	0000000000	0000000000
6		Stockpiling discontinued	1.000	ST	0000000000	0000000000
7	6.362-480.0	Gredzenblīve 12,42x 1,78	1.000	ST	0000000000	0000000000
8	5.415-603.0	Triple jet nozzle 040	1.000	ST	0000000000	0000000000
9	5.311-117.0	Hexagon nut	1.000	ST	0000000000	0000000000
10	5.037-059.0	hook	1.000	ST	0000000000	0000000000
11	5.394-269.0	Aizsargdetaja	1.000	ST	0000000000	0000000000

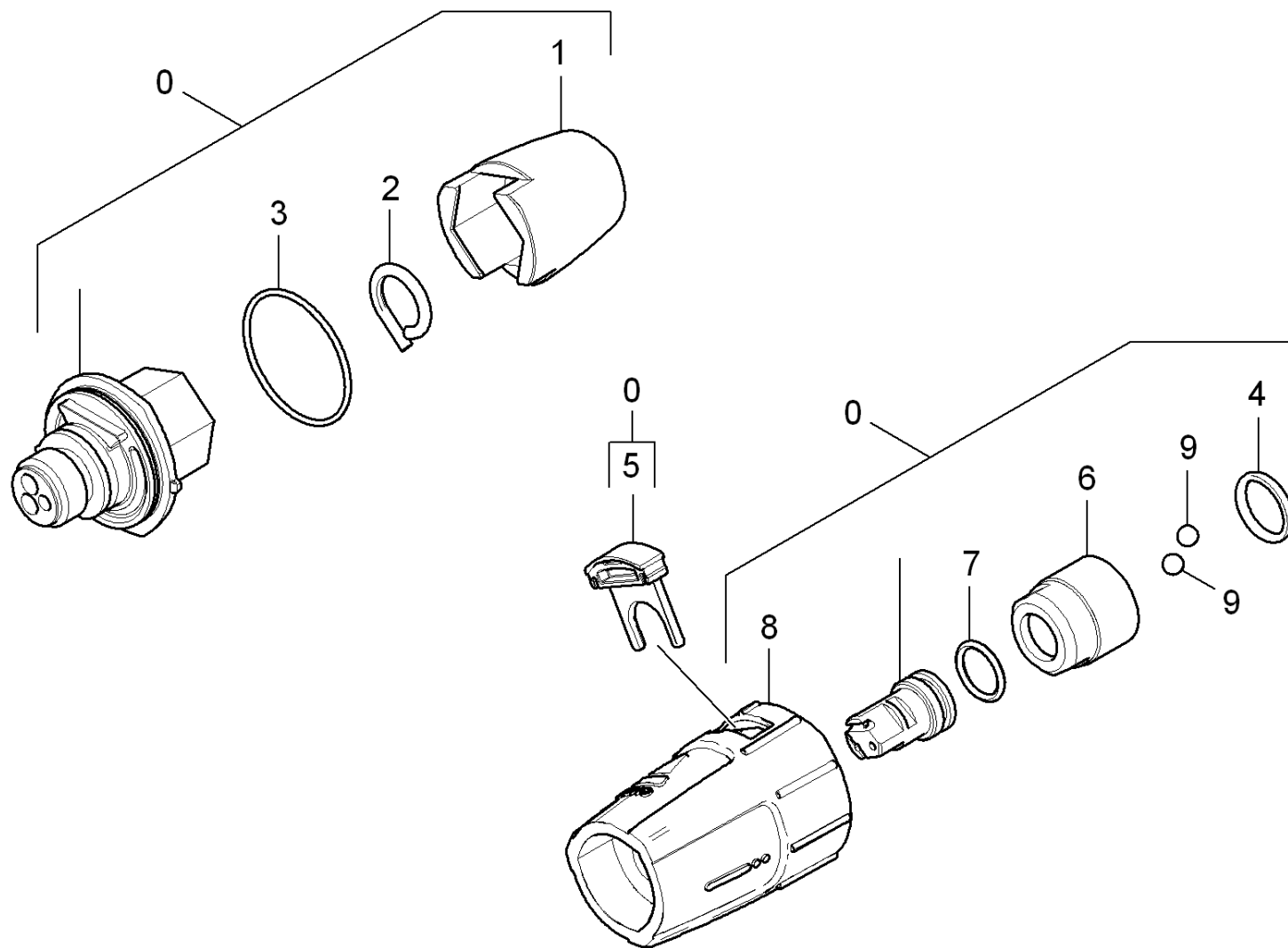

46 Nozzle

Poz.	Materiāla Nr.	Nosaukums	Daudzums	Pārdoš. vienība
0	4.767-150.0	Triple jet nozzle only for replacement 0	1.000	ST
1	5.394-530.0	Protection part complete	1.000	ST
2	6.343-150.0	Pin 03	1.000	ST
3	6.362-409.0	O-Ring seal 32,0 X 1,5	1.000	ST
4	6.362-460.0	Gredzenblīve 14,0 X 2,5-NBR 70	1.000	ST
5	5.321-884.0	Spaile	1.000	ST
6	5.311-225.0	Nut	1.000	ST
7	6.362-480.0	Gredzenblīve 12,42x 1,78	1.000	ST
8	5.394-859.0	Aizsargdetāļa	1.000	ST
9	7.401-902.0	Sfēra 5 G20 -1.4034 DIN 5401	2.000	ST

0 Triple jet nozzle only for replacement 0 (4.767-150.0)

Poz.	Nosaukums	Daudzums	Pārdoš. vienība
1	Triple jet nozzle 040	1.000	ST

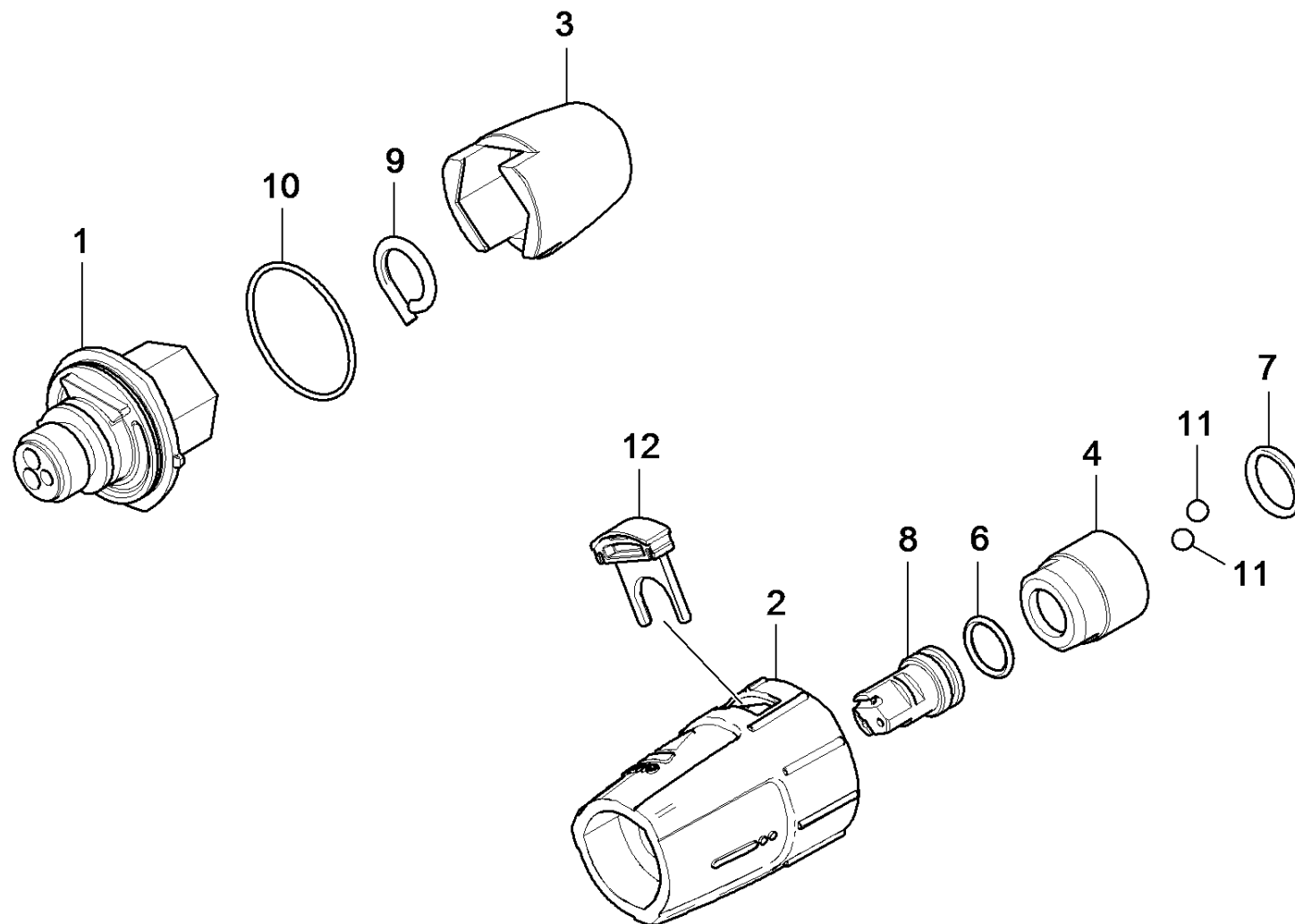

1 Triple jet nozzle 040

Poz.	Materiāla Nr.	Nosaukums	Daudzums	Pārdoš. vienība
2	5.394-859.0	Aizsargdetāja	1.000	ST
3	5.394-530.0	Protection part complete	1.000	ST
4	5.311-225.0	Nut	1.000	ST
6	6.362-480.0	Gredzenblīve 12,42x 1,78	1.000	ST
7	6.362-460.0	Gredzenblīve 14,0 X 2,5-NBR 70	1.000	ST
8	5.415-603.0	Triple jet nozzle 040	1.000	ST
9	6.343-150.0	Pin 03	1.000	ST
10	6.362-409.0	O-Ring seal 32,0 X 1,5	1.000	ST
11	7.401-902.0	Sfēra 5 G20 -1.4034 DIN 5401	2.000	ST
12	5.321-884.0	Spaile	1.000	ST