

# 34 Gear Hub 25 D14 (4.626-011.0)

Professional \ Industrial cleaning systems \ Maximum pressure cleaners \ HD 9/50-4 Cage \ Spare parts list HD 9/50-4 400V \ Pump set \ Piston \ Gear Hub 25 D14

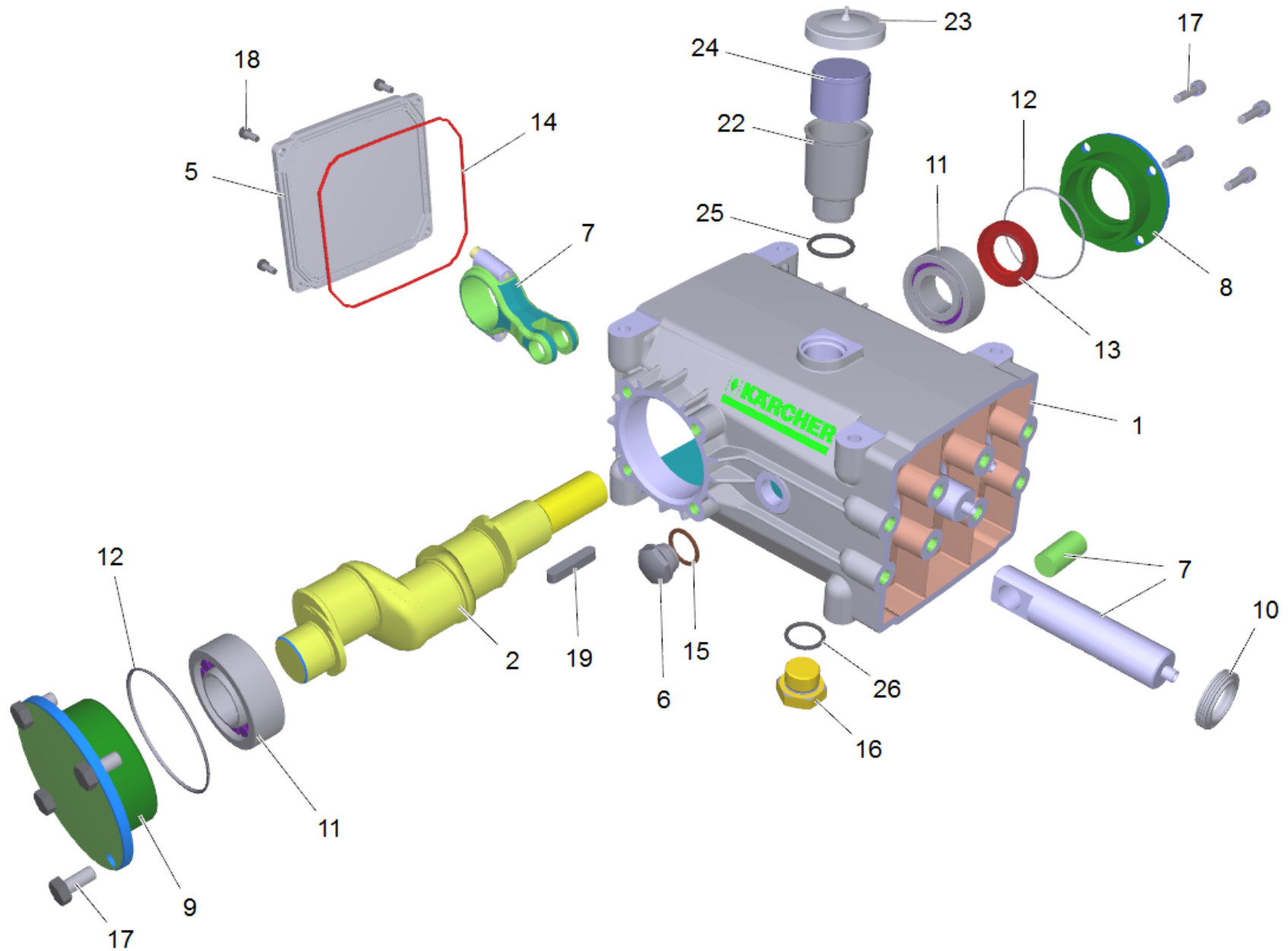

## 34 Gear Hub 25 D14 (4.626-011.0)

Professional \ Industrial cleaning systems \ Maximum pressure cleaners \ HD 9/50-4 Cage \ Spare parts list HD 9/50-4 400V \ Pump set \ Piston \ Gear Hub 25 D14

**KÄRCHER**

POS	Article no.	Description	Quantity	Unit
1	5.064-151.0	Crankcase	1	PC
2	5.103-036.0	Crankshaft lift 25	1	PC
5	5.064-154.0	Cover	1	PC
6	5.411-062.0	Screw plug	1	PC
7	4.880-006.0	Spare part set piston rod	3	PC
8	5.064-218.0	Bearing cover A	1	PC
9	5.064-219.0	Bearing cover B	1	PC
10	6.367-032.0	Rotary shaft seal 24X 35-NBR	3	PC
11	6.401-384.0	Cylindere bearing NJ 2206 E P/C3	2	PC
12	6.362-887.0	O-Ring seal 65,0 X 2,5	2	PC
13	6.367-099.0	Rotary shaft seal 52x30	1	PC
14	6.363-257.0	O-Ring seal	1	PC
15	6.362-585.0	Seal	1	PC
16	5.411-177.0	Screw plug	1	PC
17	7.304-397.0	Hexagonal head screw M8x20-8.8-A2E ISO	8	PC
18	7.306-022.0	Cylinder head screw M 6x20-8.8-A2E ISO47	4	PC
19	7.318-038.0	Parallel key A 8x7x40-C45K DIN 6885-1	1	PC
22	5.070-194.0	Tank	1	PC
23	5.064-457.0	Cover plate qusty grey oil	1	PC
24	5.132-107.0	Plug	1	PC
25	6.362-168.0	O-Ring seal 22,3 X 2,4-NBR 70	1	PC
26	6.363-319.0	O-Ring seal 21,5X3,2	1	PC