

New Unit Information



**HD 6/16-4 M, HD 7/18-4 M,
HD 9/19 M, HD 9/20-4 M**

all versions

1.524-...

These units are the new top models among the mid-range mobile high-pressure cleaner. Its compact, vertical design enables easy handling and space-saving storage.

Drive unit

- 4-pole electric motor with approx 1500 rpm.
 HD 6/16-4 ...: 230 V / 1~ / 50 Hz.
 HD 7/18-4 ...: 380 V / 1~ / 50 Hz.
 HD 9/20-4 ...: 400 V / 3~ / 50 Hz (EU I).
 230 V / 3~ / 50 Hz (EU II).
- 2-pole electric motor with approx 2800 rpm.
 HD 9/19 ...: 400 V / 3~ / 50 Hz (EU I).
 230 V / 3~ / 50 Hz (EU II).
- Air-cooled motor housing.
- Water-cooled motor housing with additional air cooling (HD 9/20-4 ... only).

Pump

- 3-piston axial pump with stainless steel pistons
- Cylinder head and water inlet made from brass.
- High-pressure and suction valves made from stainless steel.
- Direct shut-off when handgun closed due to pressure switch control.
- Overflow valve for pressure and flow control.
- Control injector.
- Non-return valve
- Pressure gauge.

Cleaning agent system

- Cleaning agent injector.
- Cleaning agent non-return valve.
- Switch CHEM system, continuously variable 2 way metering valve on the back of the unit.

Electrics

- Unit switch with overload protection.
- Pressure switch control.

HD 7/18 ...: only units:

- Pressure switch control with 2-phase switching.

Other characteristics

- Softgrip Easypress handgun with improved ergonomics.
- Maximum user convenience through improved, continuously variable pressure and water flow control.
- Servo-press rotary control with ceramic insert.
- Improved movability on stairs due to large wheels (Ø 250mm).
- Easy oil level checking from outside without removing the housing cover.

View from the front (all MX versions)



- | | |
|--|-------------------------------|
| 1 Safety latch | 12 Water connection |
| 2 Trigger lever | 13 Pressure gauge |
| 3 Softgrip easy-press handgun | 14 Oil level check |
| 4 Servo-press rotary control | 15 Unit cover |
| 5 High-pressure hose | 16 Unit switch (Q1) |
| 6 Steel tube with roll-over handle | 17 Unit cover retaining screw |
| 7 Mains plug (3~) | 18 Crank handle, hose reel |
| 8 Mains cable | 19 Hose reel |
| 9 Mains plug (1~) | 20 Sliding handle |
| 10 Three-way nozzle | |
| 11 Roller guide for high-pressure hose | |

View from the front (all M versions)



- | | | | |
|----|----------------------------------|----|----------------------------|
| 1 | Safety latch | 11 | Mains plug (3~) |
| 2 | Trigger lever | 12 | Mains cable |
| 3 | Softgrip easy-press handgun | 13 | Mains plug (1~) |
| 4 | Servo-press rotary control | 14 | Oil level check |
| 5 | High-pressure hose | 15 | Unit cover |
| 6 | Steel tube with roll-over handle | 16 | Unit switch (Q1) |
| 7 | Pressure gauge | 17 | Unit cover retaining screw |
| 8 | Three-way nozzle | 18 | Carrying handle |
| 9 | High-pressure connection | 19 | Sliding handle |
| 10 | Water connection | | |

Rear view



M unit

- 1 Hose reel (only MX unit)
- 2 Crank handle, hose reel (only MX unit)
- 3 High-pressure hose
- 4 Cleaning agent bottle
- 5 Mains cable storage and compartment for spare nozzle
- 6 Connection 2, cleaning agent bottle
- 7 Storage compartment 2, cleaning agent bottle
- 8 Storage compartment 1, cleaning agent bottle
- 9 Connection 1, cleaning agent bottle
- 10 Cleaning agent metering valve and switchover from cleaning agent bottle 1 to cleaning agent bottle 2
- 11 Storage, handgun
- 12 Dirt blaster (accessories, supplied with Plus units)

View from below, pump head HD 6/16-4 and HD 9/20-4

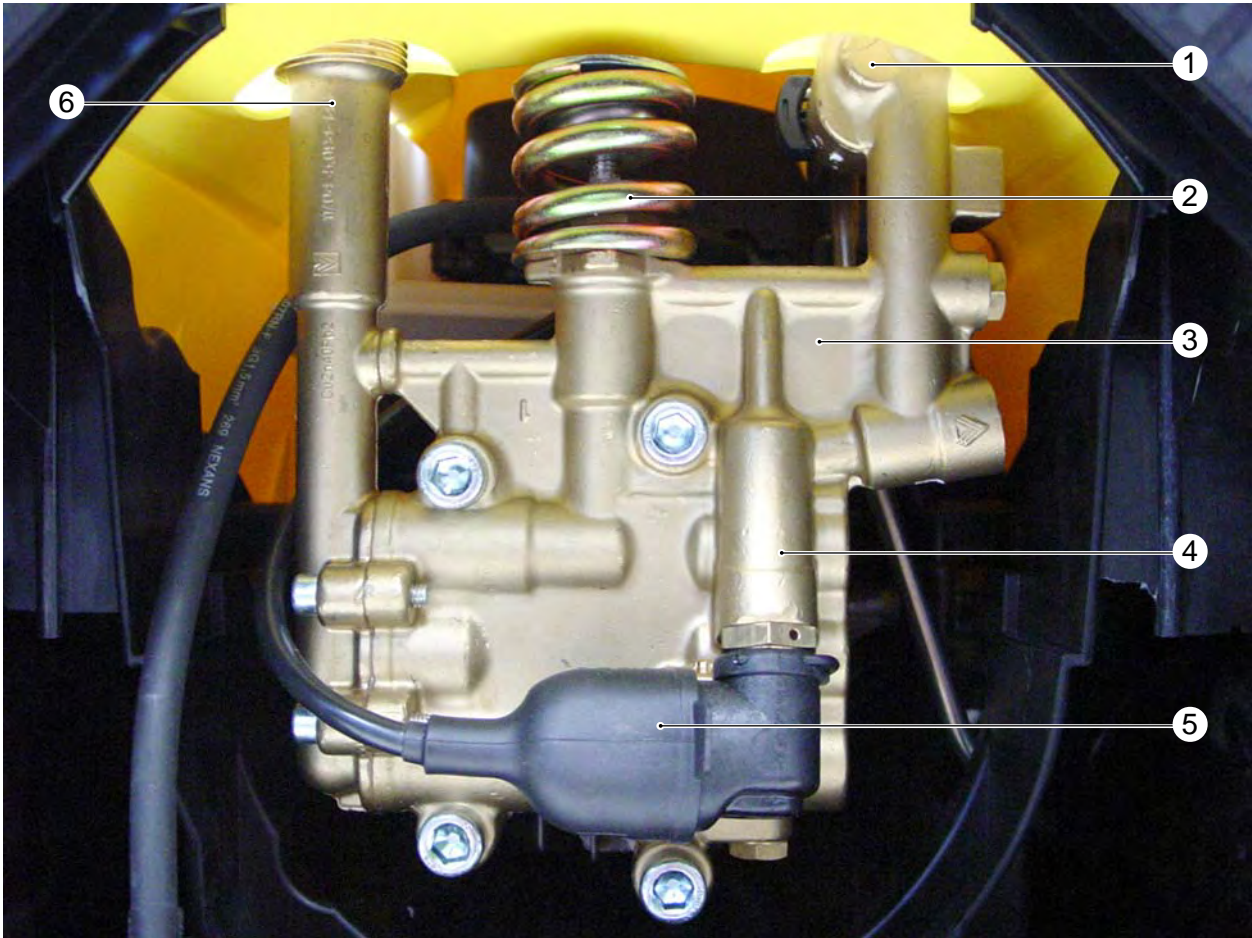

Pump head 1~unit

- 1 High-pressure connection
- 2 Overflow valve
- 3 Pump head (HD 6/16-4, HD 9/20-4)
- 4 Control piston, pressure switch
- 5 Pressure switch (Q2) (HD 6/16-4, HD 9/20-4)
- 6 Water connection

Note:

The pressure switch (Q2) cannot be adjusted!

View from below, pump head HD 7/18-4 and HD 9/19

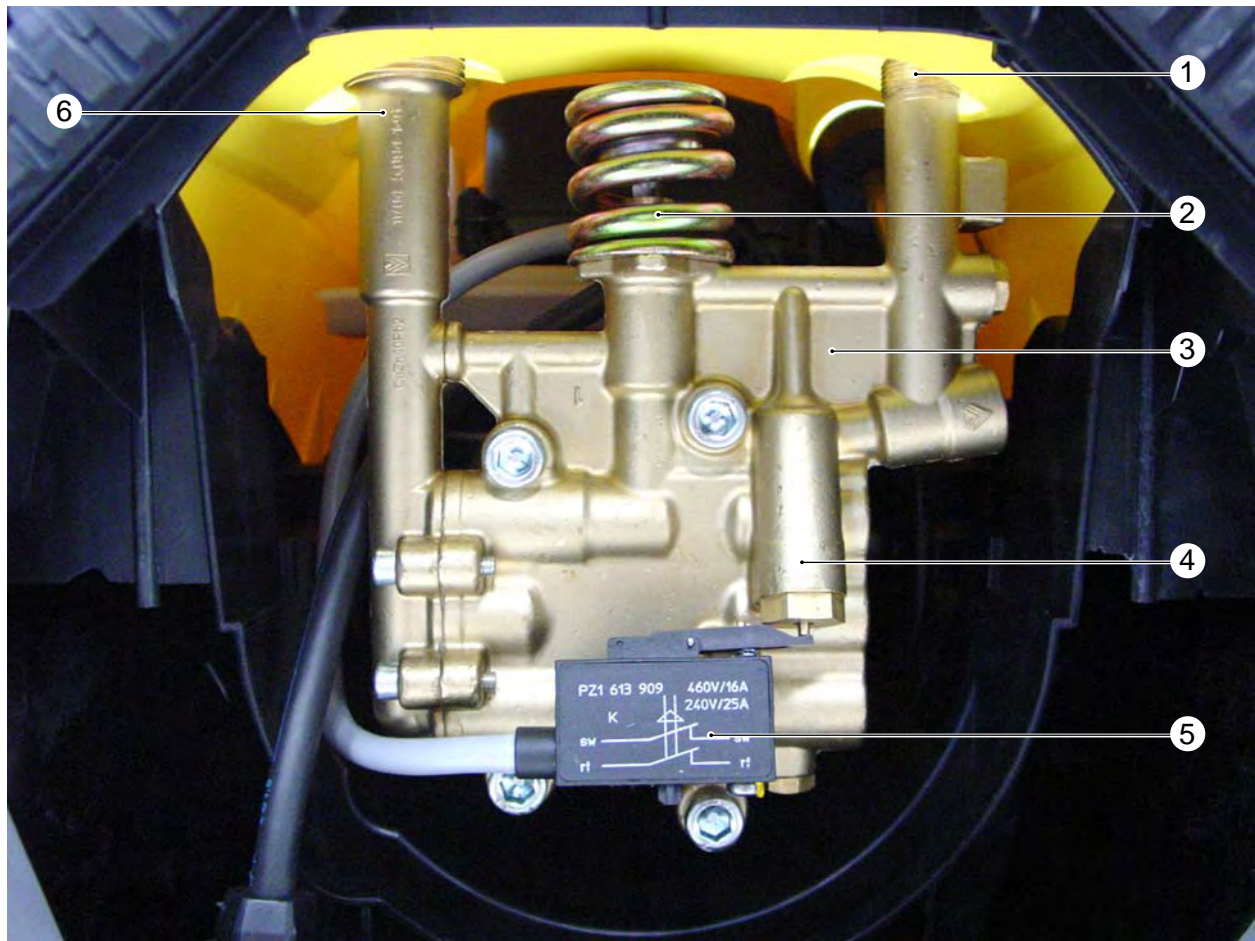

Pump head 3-unit

- 1 High-pressure connection
- 2 Overflow valve
- 3 Pump head (HD 7/18-4, HD 9/19)
- 4 Control piston, pressure switch
- 5 Pressure switch (Q2) (HD 7/18-4, HD 9/19)
- 6 Water connection

Note:

The pressure switch (Q2) cannot be adjusted!

View from the front (housing open / air-cooled motor)

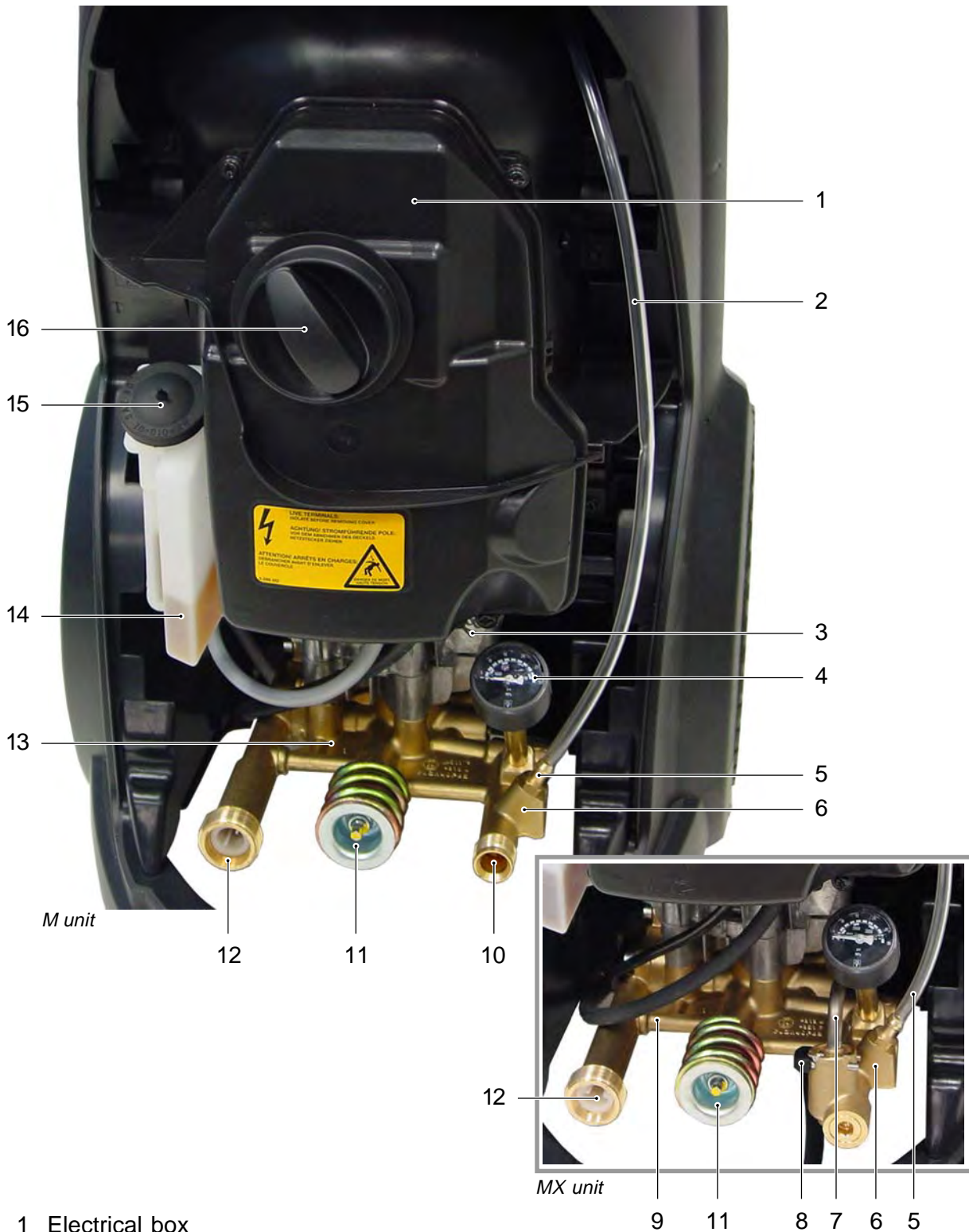

- 1 Electrical box
- 2 Cleaning agent hose
- 3 Motor
- 4 Pressure gauge
- 5 Cleaning agent connection with non-return valve
- 6 Cleaning agent injector
- 7 High-pressure tube (MX unit only)
- 8 Retaining clip, for holding the high-pressure tube (MX unit only)

- 9 Pump head (MX unit)
- 10 High-pressure connection
- 11 Overflow valve
- 12 Water connection
- 13 Pump head (M unit)
- 14 Oil reservoir
- 15 Oil reservoir fastener
- 16 Unit switch

View from the front (housing open / air/water-cooled motor)

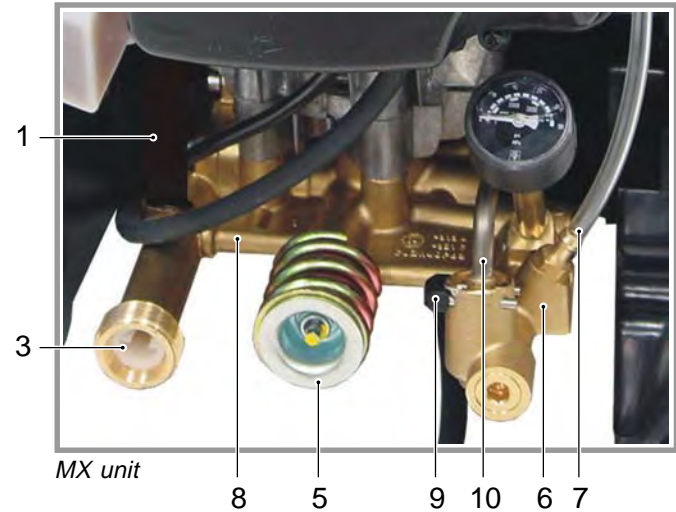
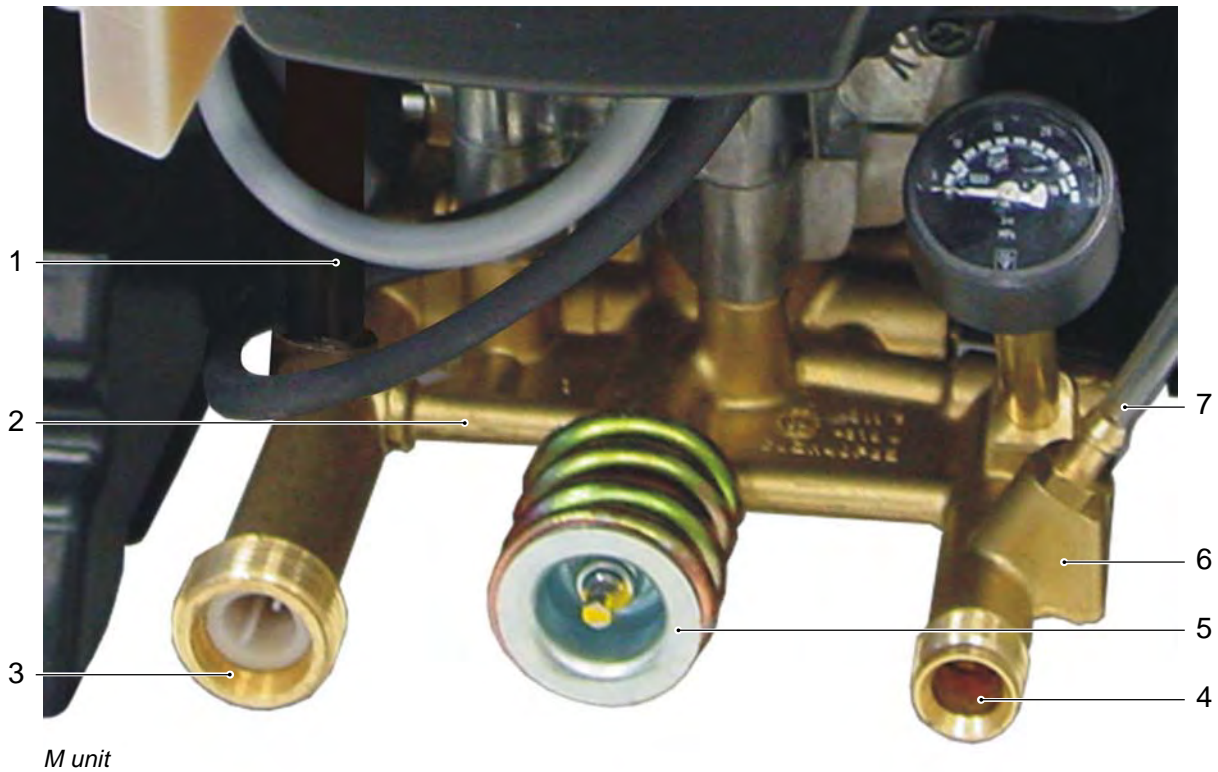

- 1 Connection, motor water-cooling
- 2 Pump head, M unit
- 3 Water connection
- 4 High-pressure connection
- 5 Overflow valve
- 6 Cleaning agent injector

- 7 Cleaning agent connection with non-return valve
- 8 Pump head, MX unit
- 9 Retaining clip, for holding the high-pressure tube (MX unit only)
- 10 High-pressure tube (MX unit only)

Electrical box open, HD 6/16-4

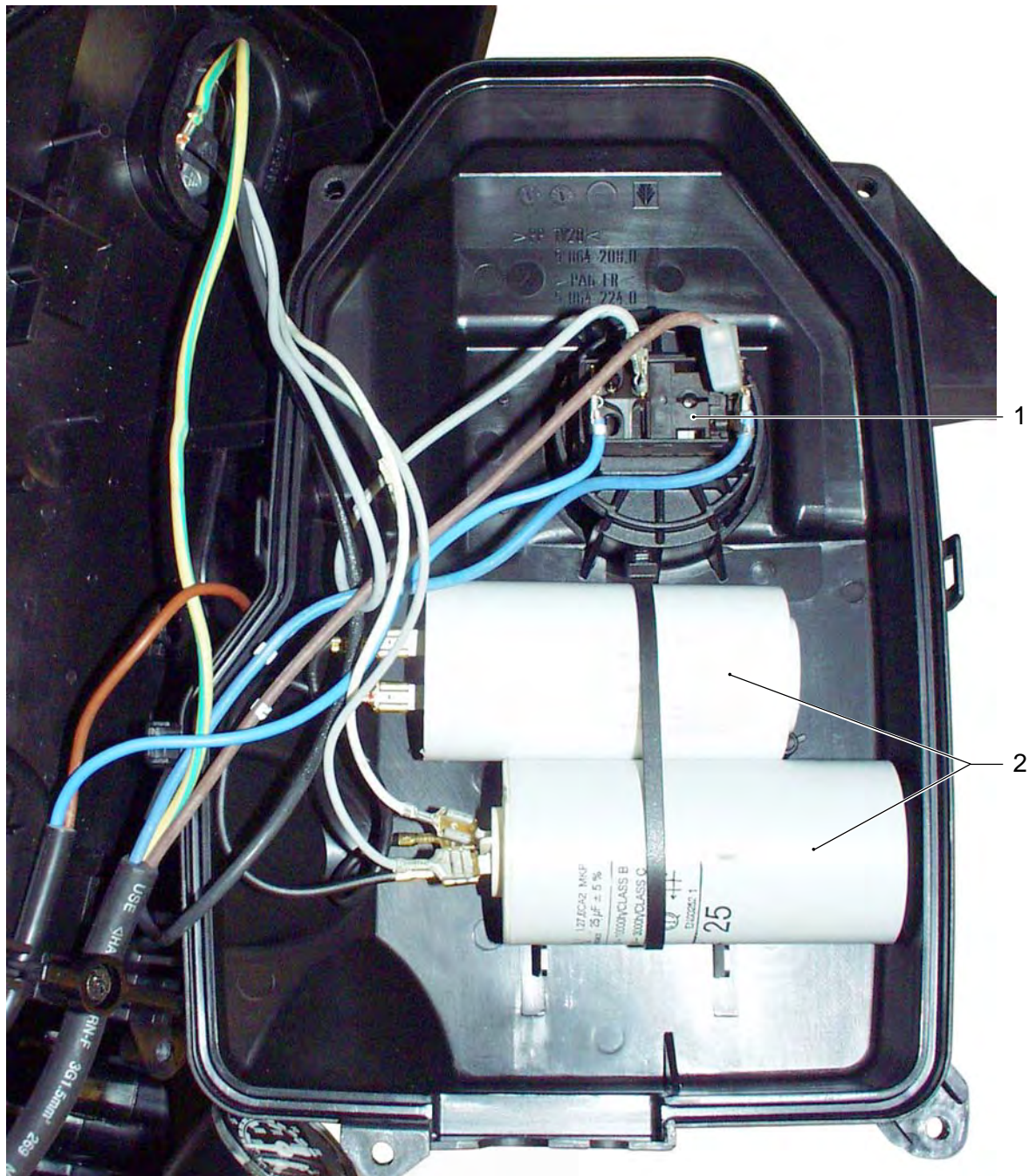

- 1 Unit switch (Q1)
- 2 Operating capacitors (2x 30µF)

Electrical box open, HD 7/18-4 and HD 9/19

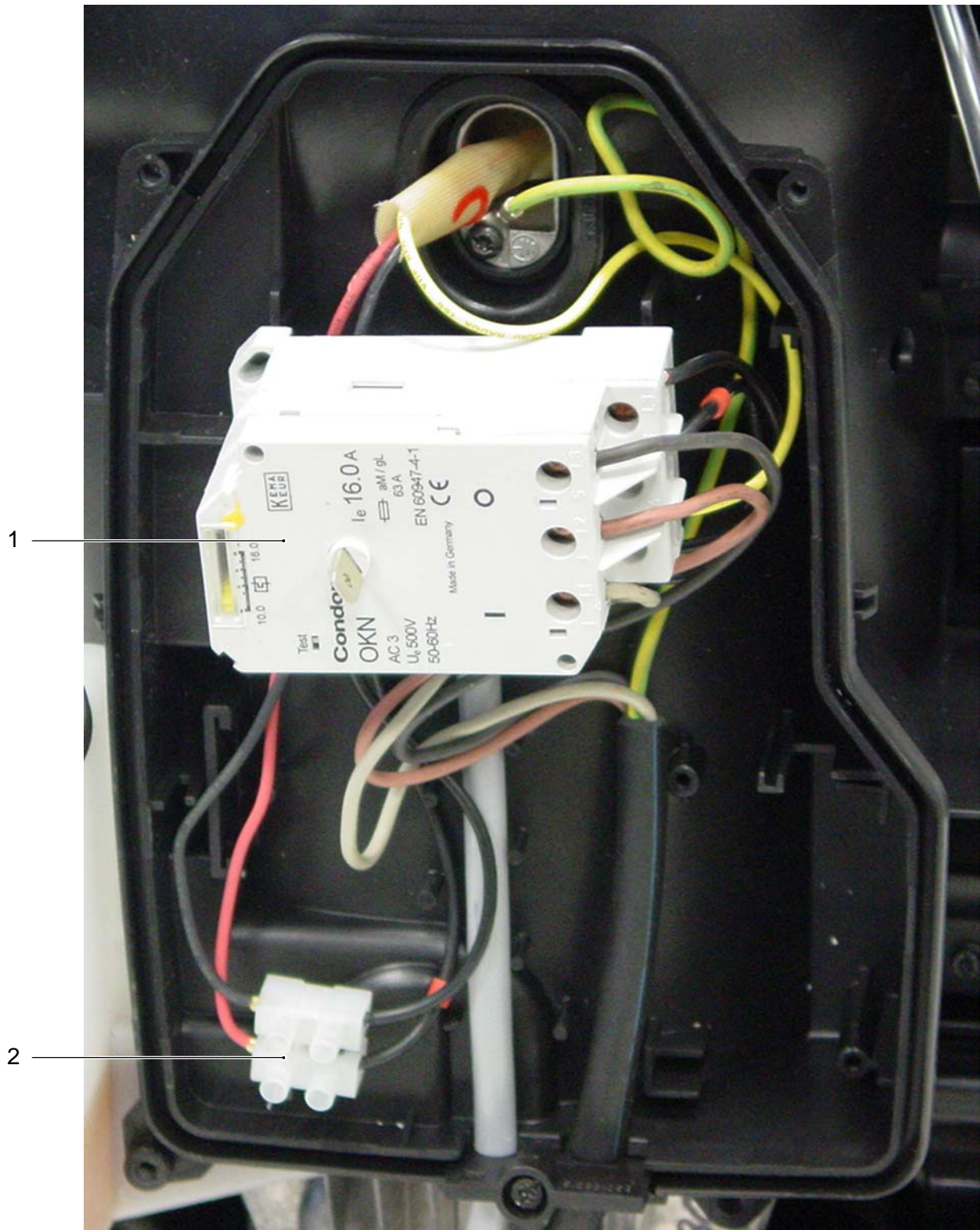

- 1 Unit switch (Q1)
- 2 Terminal strip, pressure switch (Q2)

Electrical box open, HD 7/18-4 and HD 9/19

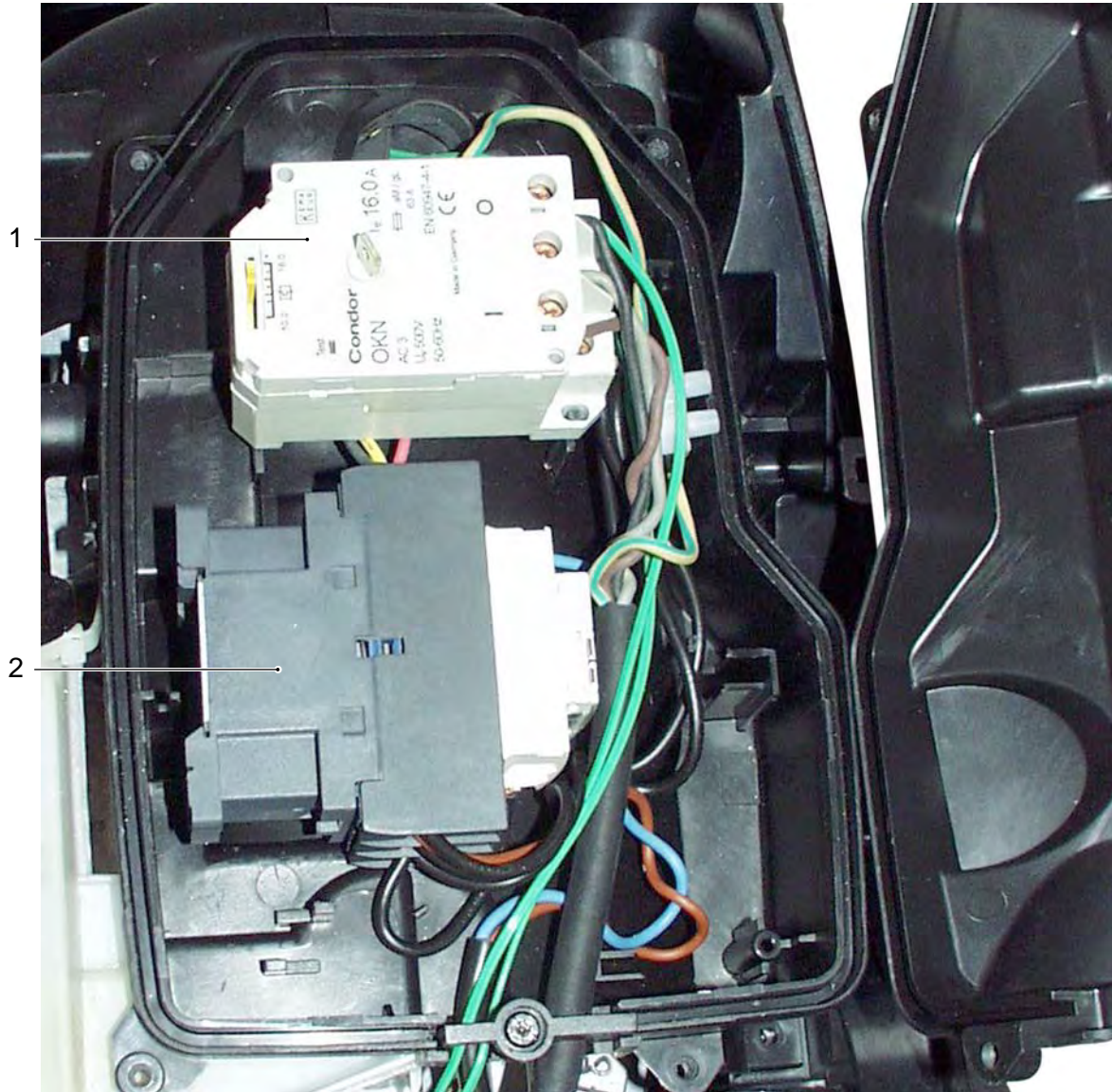

- 1 Unit switch (Q1)
- 2 Contactor

Motor pump unit

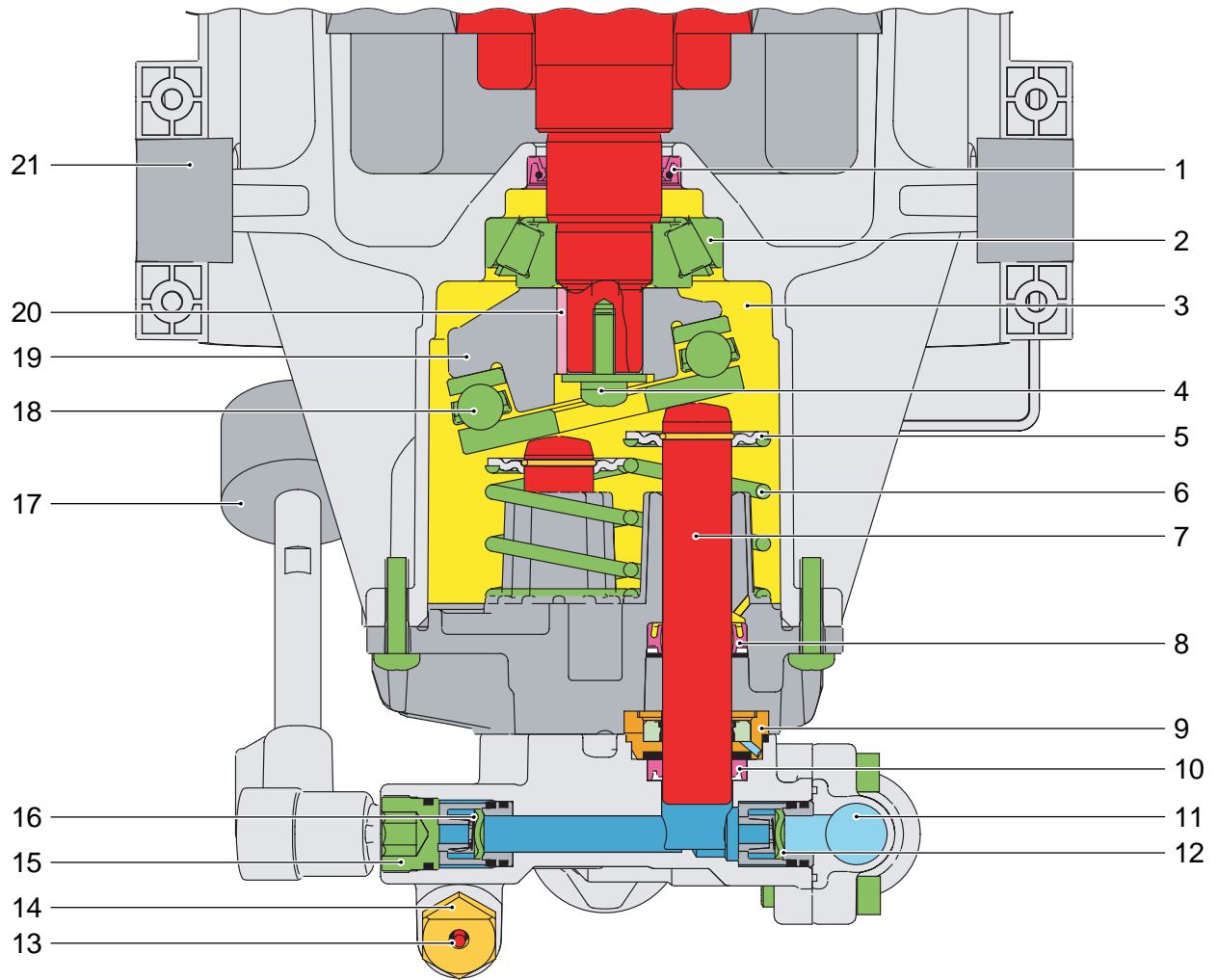

- | | |
|----------------------------------|--|
| 1 Shaft seal | 12 Suction valve |
| 2 Lower motor bearing | 13 Control piston, pressure switch |
| 3 Oil bath | 14 Control piston threaded connection, pressure switch |
| 4 Swash plate retaining screw | 15 Screw plug for pressure valve |
| 5 Fixing plate for piston spring | 16 Pressure valve |
| 6 Piston spring | 17 Pressure gauge |
| 7 Piston | 18 Thrust bearing |
| 8 Oil seal | 19 Swash plate |
| 9 Low-pressure seal | 20 Key |
| 10 High-pressure seal | 21 Rubber motor bearing |
| 11 Pump - intake side | |

Pump with overflow valve, HD 6/16-4 and HD 9/20-4

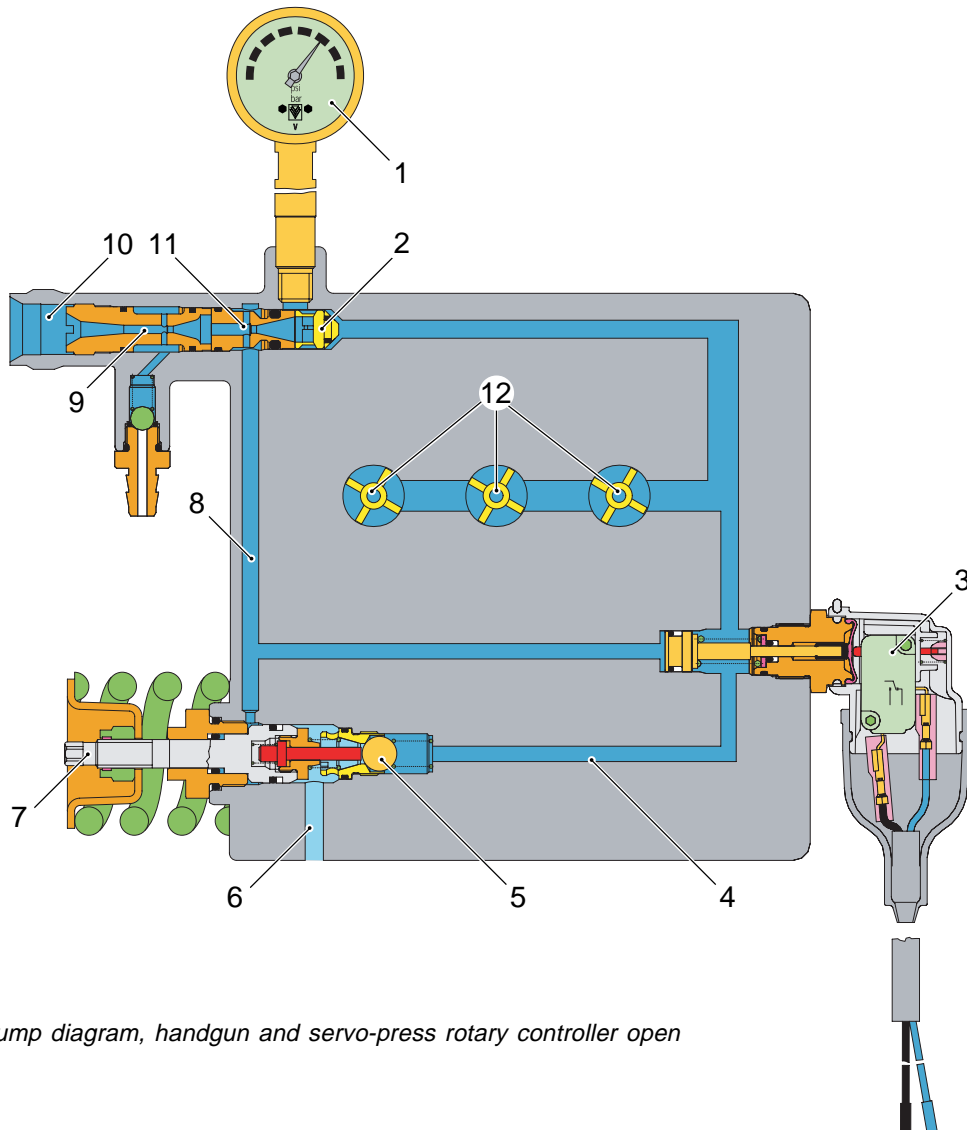

Pump diagram, handgun and servo-press rotary controller open

- 1 Pressure gauge
- 2 Non-return valve
- 3 Pressure switch (Q2)
- 4 Connection bore to overflow valve
- 5 Overflow valve ball
- 6 Connection bore to the suction chamber
- 7 Piston rod
- 8 Connection bore to the control pressure injector
- 9 Cleaning agent injector
- 10 High-pressure outlet
- 11 Control pressure injector
- 12 Pressure chamber with pressure valves

If the servo-press rotary control is fully open the water flows from the pressure chamber (12), through the non-return valve (2), through the control pressure injector (11) to the high-pressure outlet (10).

The pump pressure pushes the ball (5) of the overflow valve onto the valve seat and therefore seals off the connection bore (6) to the suction chamber. The pressure gauge (1) displays the operating pressure in the pressure chamber (12). However, the effect of the control pressure injector (11) causes a lower pressure in the connection bore (8).

Pump with overflow valve, HD 6/16-4 and HD 9/20-4

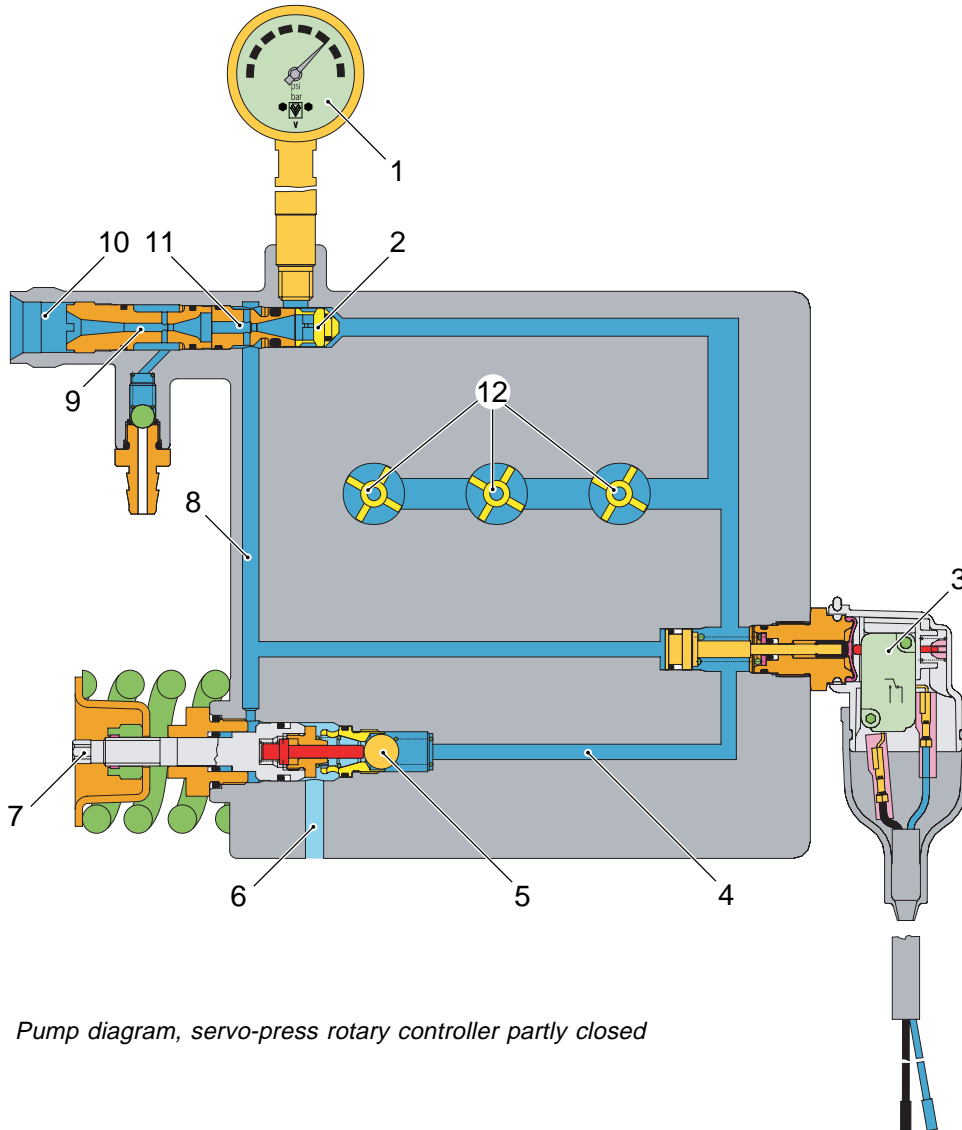

Pump diagram, servo-press rotary controller partly closed

- 1 Pressure gauge
- 2 Non-return valve
- 3 Pressure switch (Q2)
- 4 Connection bore to overflow valve
- 5 Overflow valve ball
- 6 Connection bore to the suction chamber
- 7 Piston rod
- 8 Connection bore to the control pressure injector
- 9 Cleaning agent injector
- 10 High-pressure outlet
- 11 Control pressure injector
- 12 Pressure chamber with pressure valves

If the servo-press rotary controller is partly closed the pressure in the pressure chamber (12) no longer increases. However, the reduced water flow reduces the effect of the control pressure injector (11), so that the pressure in the connection bore (8) rises. This pushes the piston rod (7) slightly to the right against the spring pressure. The spindle point of the rod pushes the ball (5) out of its seat slightly so that part of the pumped flow flows to the suction chamber.

The pressure switch (3) is pressed slightly to the right by the increased pressure in the connection bore (8), however not far enough to switch off the pressure switch.

Pump with overflow valve, HD 6/16-4 and HD 9/20-4

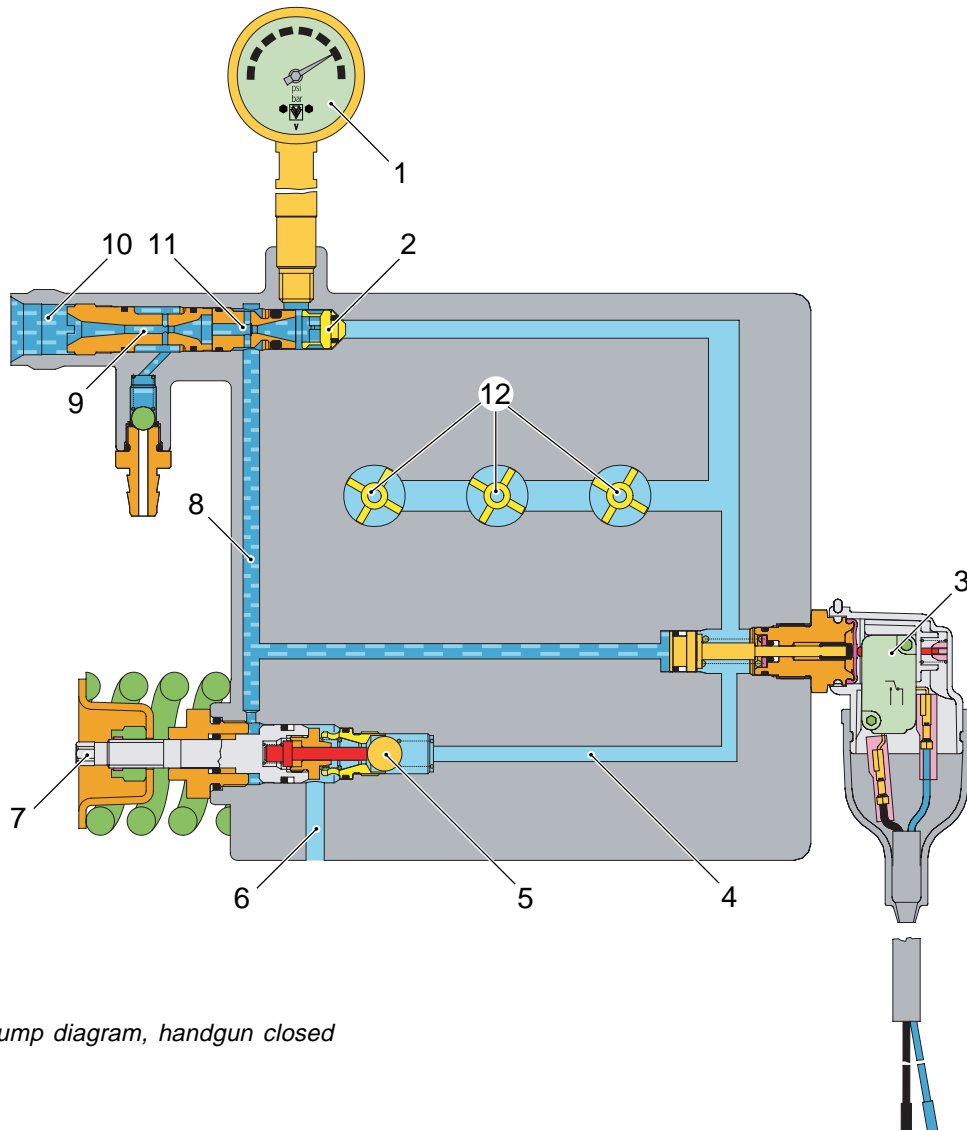

Pump diagram, handgun closed

- 1 Pressure gauge
- 2 Non-return valve
- 3 Pressure switch (Q2)
- 4 Connection bore to overflow valve
- 5 Overflow valve ball
- 6 Connection bore to the suction chamber
- 7 Piston rod
- 8 Connection bore to the control pressure injector
- 9 Cleaning agent injector
- 10 High-pressure outlet
- 11 Control pressure injector
- 12 Pressure chamber with pressure valves

When the handgun is closed the pressure in the pressure chamber (12) suddenly rises. This peak pressure acts through the connection bores (8) on the piston rod (7) and the pressure switch (3). The ball (5) is pushed out of its seat by the piston rod (7) and the whole pumped flow can flow through the connection bore (6) to the suction chamber.

The pressure switch (3) switches off the motor. As soon as the handgun is closed the non-return valve (2) closes. This means the full system pressure between the handgun and non-return valve remains enclosed.

If the handgun is opened again the pressure in the system drops suddenly, the overflow valve returns to its original position and the pressure switch (3) switches the motor back on.

Pump with overflow valve, HD 7/18-4 and HD 9/19

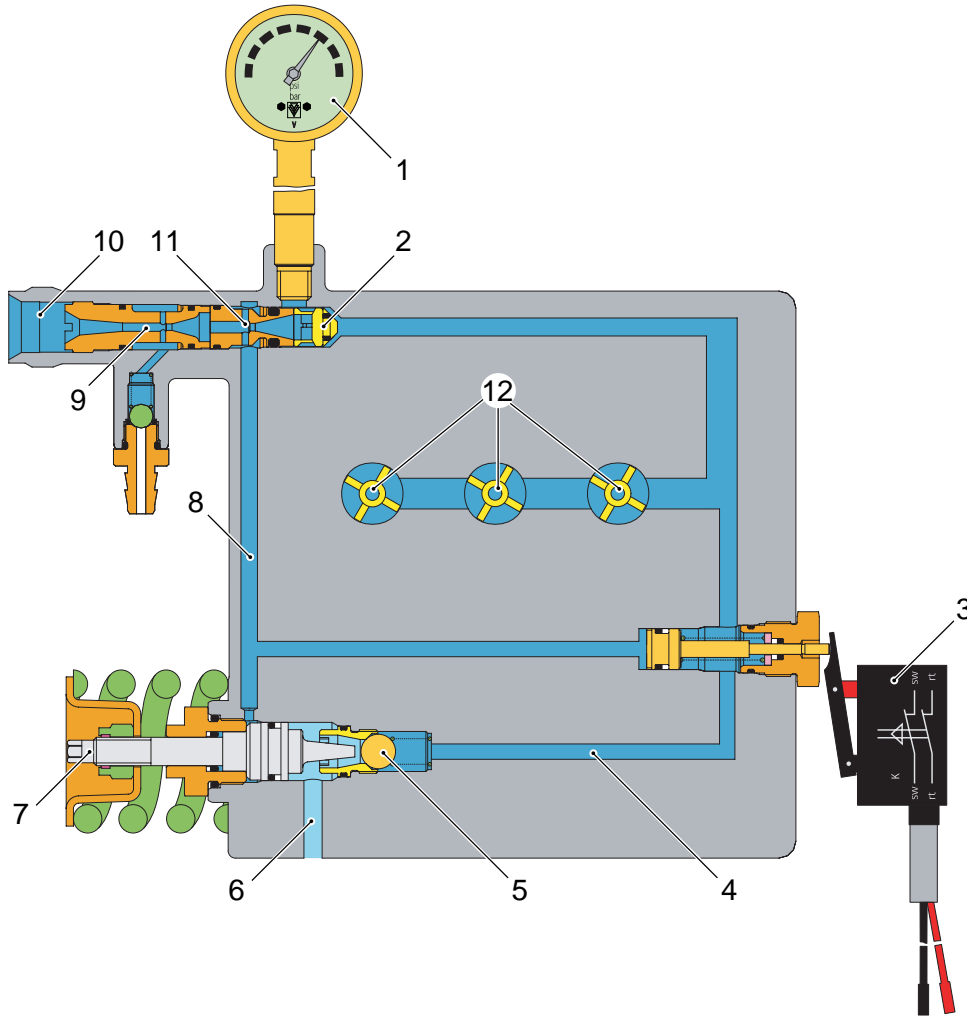

Pump diagram, handgun and servo-press rotary controller open

- 1 Pressure gauge
- 2 Non-return valve
- 3 Pressure switch (Q2)
- 4 Connection bore to overflow valve
- 5 Overflow valve ball
- 6 Connection bore to the suction chamber
- 7 Piston rod
- 8 Connection bore to the control pressure injector
- 9 Cleaning agent injector
- 10 High-pressure outlet
- 11 Control pressure injector
- 12 Pressure chamber with pressure valves

If the servo-press rotary control is fully open the water flows from the pressure chamber (12), through the non-return valve (2), through the control pressure injector (11) to the high-pressure outlet (10).

The pump pressure pushes the ball (5) of the overflow valve onto the valve seat and therefore seals off the connection bore (6) to the suction chamber. The pressure gauge (1) displays the operating pressure in the pressure chamber (12). However, the effect of the control pressure injector (11) causes a lower pressure in the connection bore (8).

Pump with overflow valve, HD 7/18-4 and HD 9/19

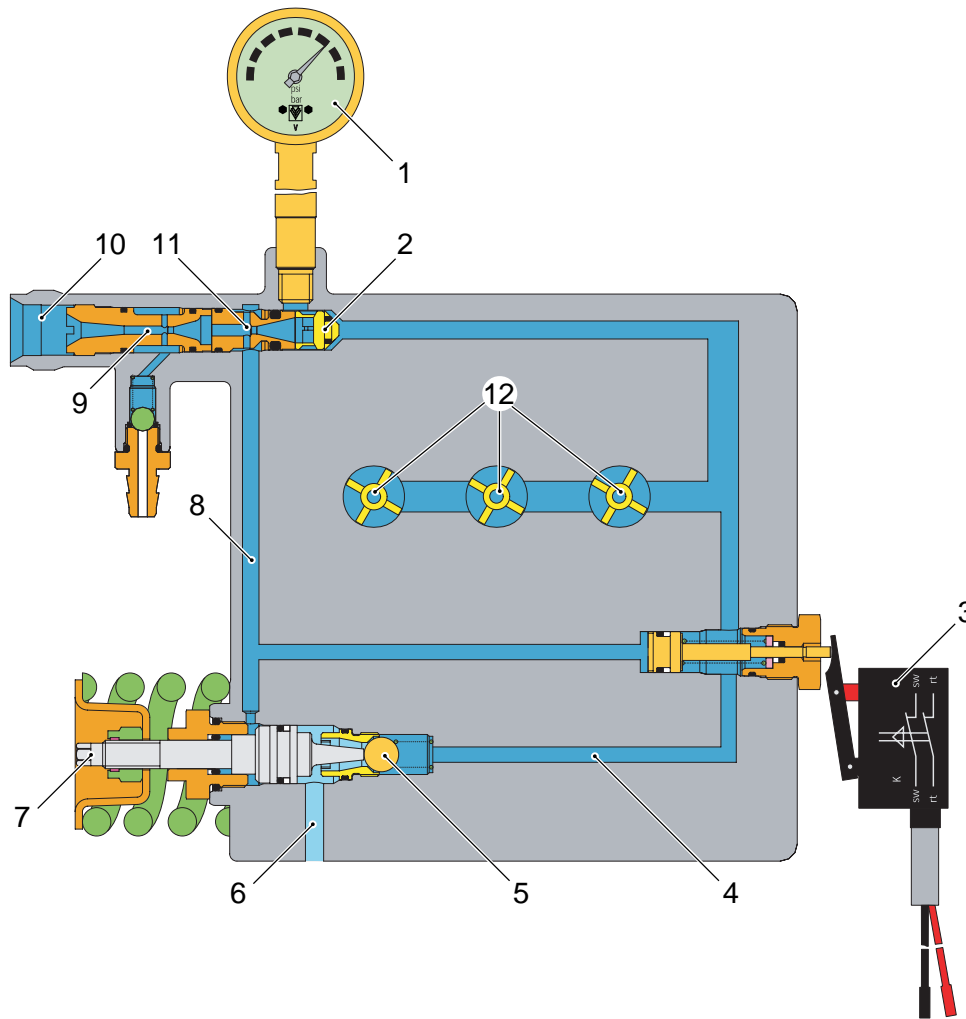

Pump diagram, servo-press rotary controller partly closed

- 1 Pressure gauge
- 2 Non-return valve
- 3 Pressure switch (Q2)
- 4 Connection bore to overflow valve
- 5 Overflow valve ball
- 6 Connection bore to the suction chamber
- 7 Piston rod
- 8 Connection bore to the control pressure injector
- 9 Cleaning agent injector
- 10 High-pressure outlet
- 11 Control pressure injector
- 12 Pressure chamber with pressure valves

If the servo-press rotary controller is partly closed the pressure in the pressure chamber (12) no longer increases. However, the reduced water flow reduces the effect of the control pressure injector (11), so that the pressure in the connection bore (8) rises. This pushes the piston rod (7) slightly to the right against the spring pressure. The spindle point of the rod pushes the ball (5) out of its seat slightly so that part of the pumped flow flows to the suction chamber.

The pressure switch (3) is pressed slightly to the right by the increased pressure in the connection bore (8), however not far enough to switch off the pressure switch.

Pump with overflow valve, HD 7/18-4 and HD 9/19

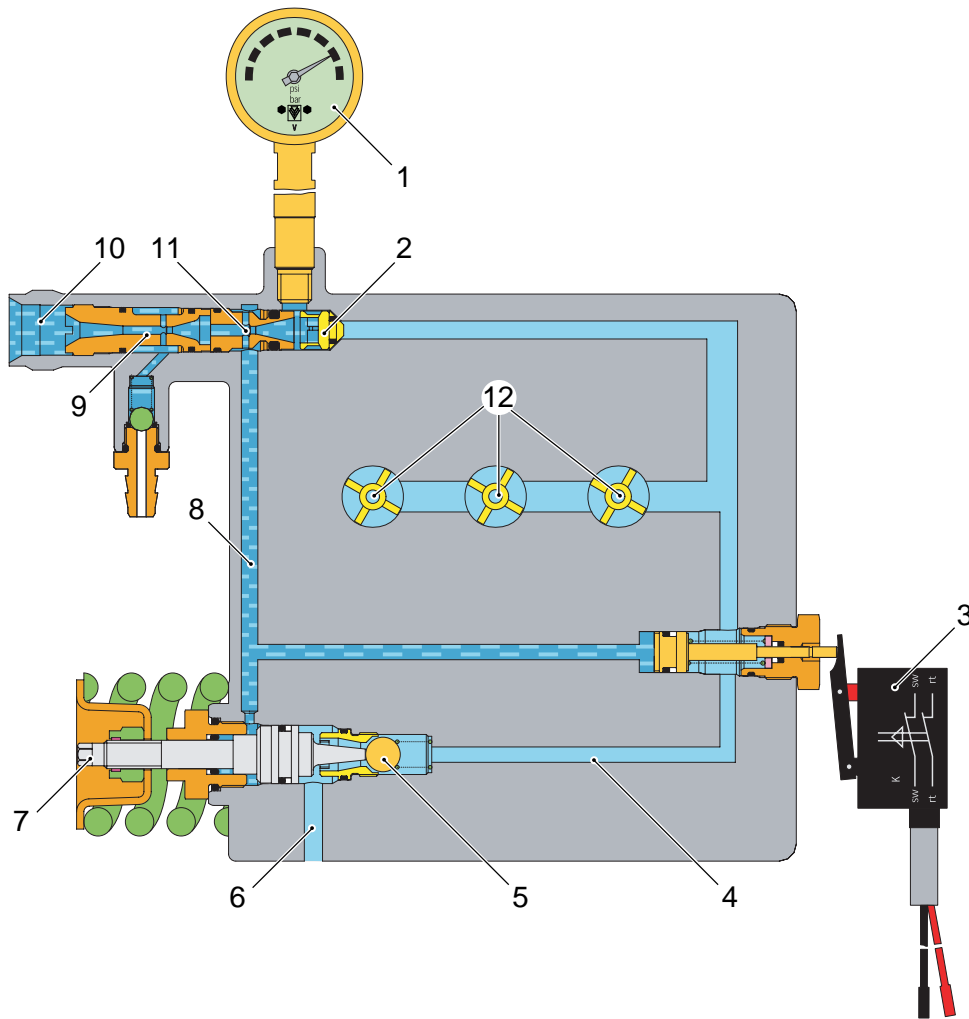

Pump diagram, handgun closed

- 1 Pressure gauge
- 2 Non-return valve
- 3 Pressure switch (Q2)
- 4 Connection bore to overflow valve
- 5 Overflow valve ball
- 6 Connection bore to the suction chamber
- 7 Piston rod
- 8 Connection bore to the control pressure injector
- 9 Cleaning agent injector
- 10 High-pressure outlet
- 11 Control pressure injector
- 12 Pressure chamber with pressure valves

When the handgun is closed the pressure in the pressure chamber (12) suddenly rises. This peak pressure acts through the connection bores (8) on the piston rod (7) and the pressure switch (3). The ball (5) is pushed out of its seat by the piston rod (7) and the whole pumped flow can flow through the connection bore (6) to the suction chamber.

The pressure switch (3) switches 2 of the 3 phases off, causing the motor to switch off.

As soon as the handgun is closed the non-return valve (2) closes. This means the full system pressure between the handgun and non-return valve remains enclosed.

If the handgun is opened again the pressure in the system drops suddenly, the overflow valve returns to its original position and the pressure switch (3) switches the motor back on.

Softgrip easy-press handgun

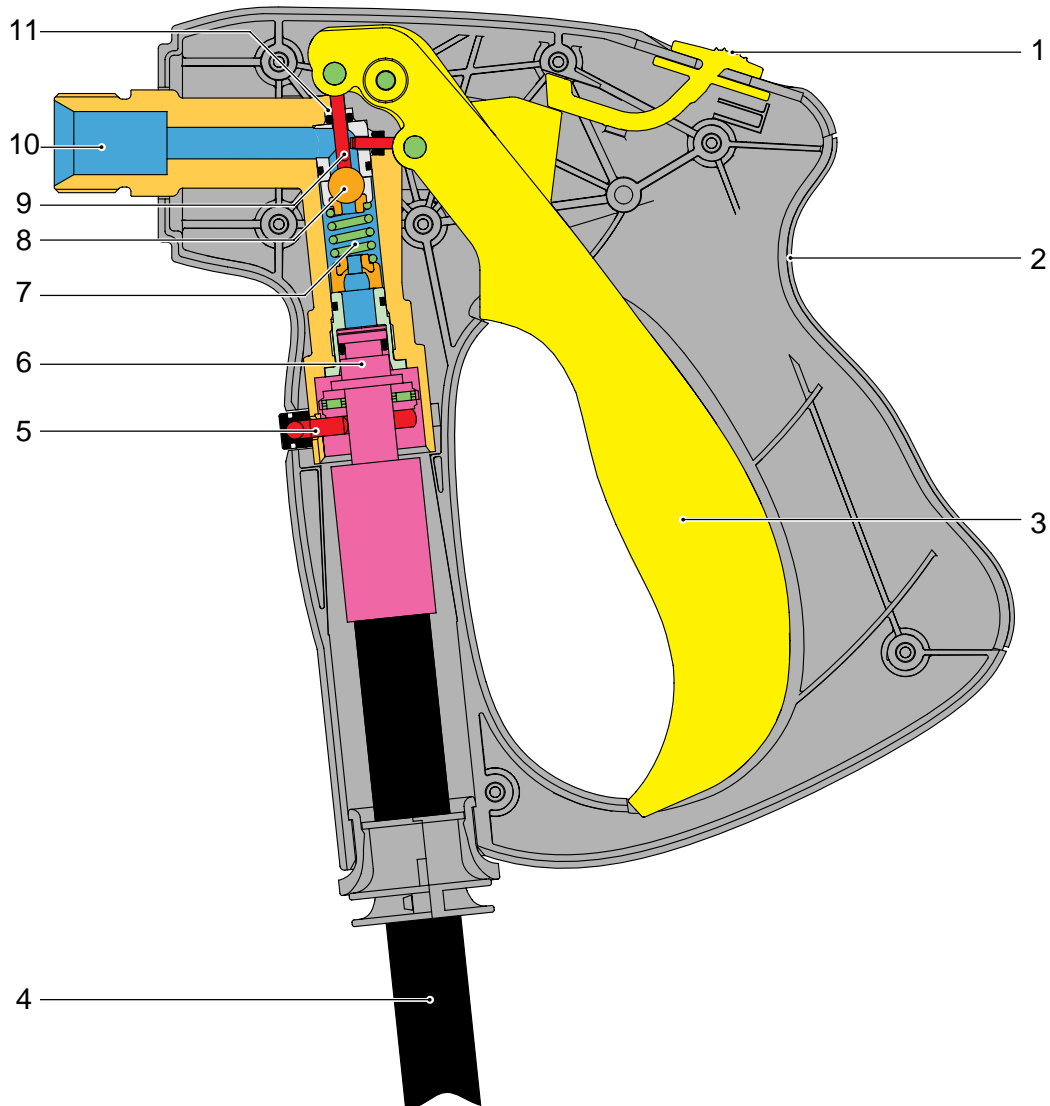

- 1 Safety latch
- 2 Handgun cover
- 3 Trigger lever
- 4 High-pressure hose
- 5 Safety bolt
- 6 Coupling, handgun - hose
- 7 Spring
- 8 Valve ball
- 9 Valve piston
- 10 Connection for spray lance
- 11 O-ring / support ring

When the trigger lever (3) is pressed, the valve piston (9) presses the valve ball (8) downwards against the spring (7). The water can flow from the hose (4) through the handgun into the spray lance.

The hose (4) can be pulled downwards and out of the handgun by pulling out the safety bolt (5).

Pressure / flow control (servo-press rotary control)

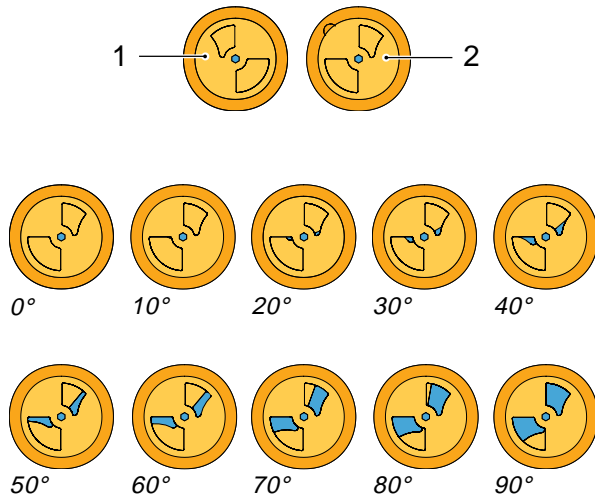

Water flow at opening angle 0° - 90°

The pressure and flow control is designed as a rotary control between the handgun and spray lance.

There are two ceramic discs (1, 2) inside the high-pressure duct.

The ceramic disc (2) is rigidly connected to the handgun connection (6). The ceramic disc (1) is connected to the rotary control (5) and can therefore be adjusted. The holes in the ceramic discs (1, 2) are staggered; this enables the flow rate and pressure to be varied when the discs are rotated.

The diagram shows the two superimposed ceramic discs (1, 2) and the water flow (blue) at various opening angles of 0° - 90°.

At the minimum setting the water flows through a small hole in the middle of the ceramic discs (1, 2).

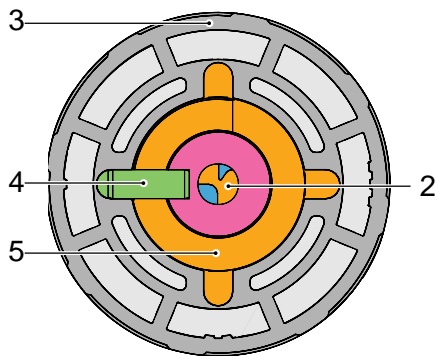

Cross-section through servo-press rotary control (handgun side)

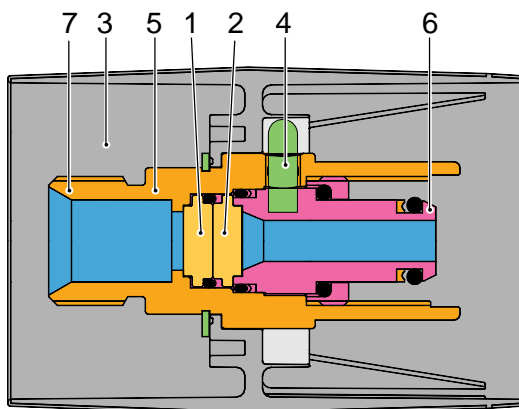

- 1 Ceramic disc - spray lance side
- 2 Ceramic disc - handgun side
- 3 Rotary control handle
- 4 Connecting pin
- 5 Rotary control housing
- 6 Handgun connection
- 7 Spray lance connection

Longitudinal section through servo-press rotary control

Three-way nozzle

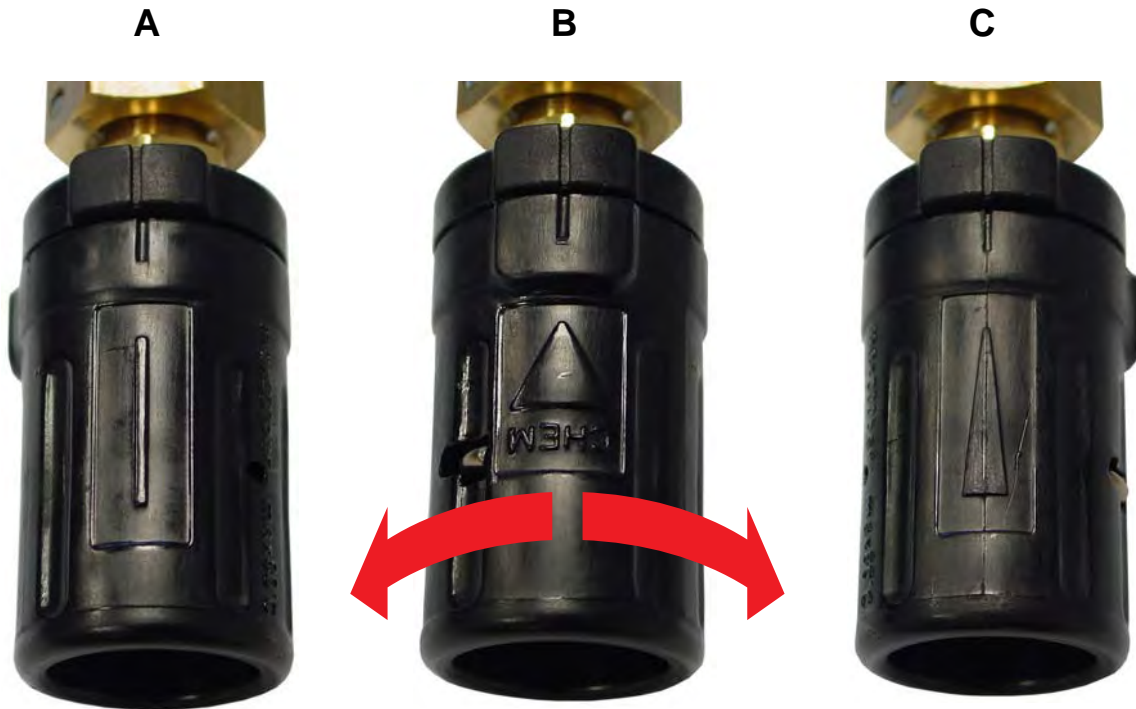

The triple nozzle can be set to three positions. Rotate the nozzle head (4) to switch between the chemicals nozzle (3) and the high-pressure nozzles (1, 2). The symbol on the nozzle head indicates which type of nozzle is set.

Setting (A) means high-pressure pencil jet.

Setting (B) means low-pressure fan jet. This setting is used to apply the cleaning agent.

Setting (C) means high-pressure fan jet.

To set the required nozzle type, the handgun must be closed and the nozzle head rotated to the positions (A, B, C) shown above.

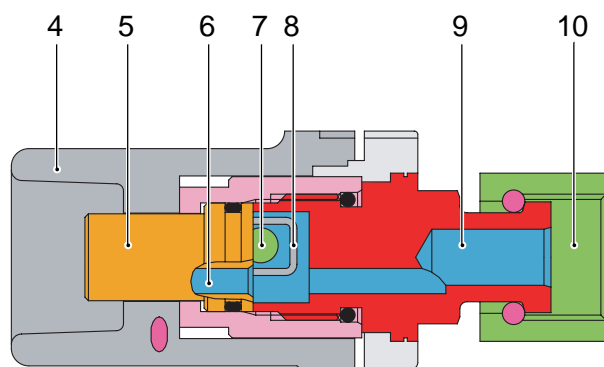
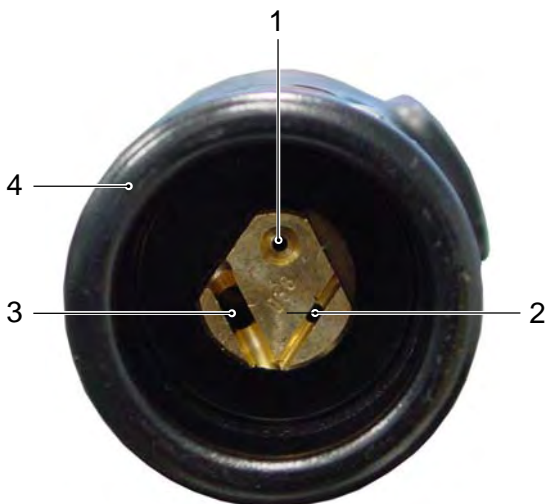

- 1 High-pressure pencil jet (A)
- 2 High-pressure fan jet (C)
- 3 Low-pressure fan jet (B)
- 4 Adjustable nozzle head
- 5 Nozzle

- 6 Nozzle duct
- 7 Valve ball 2x
- 8 Valve ball cage
- 9 High-pressure duct
- 10 Spray lance connection

Set the overflow valve

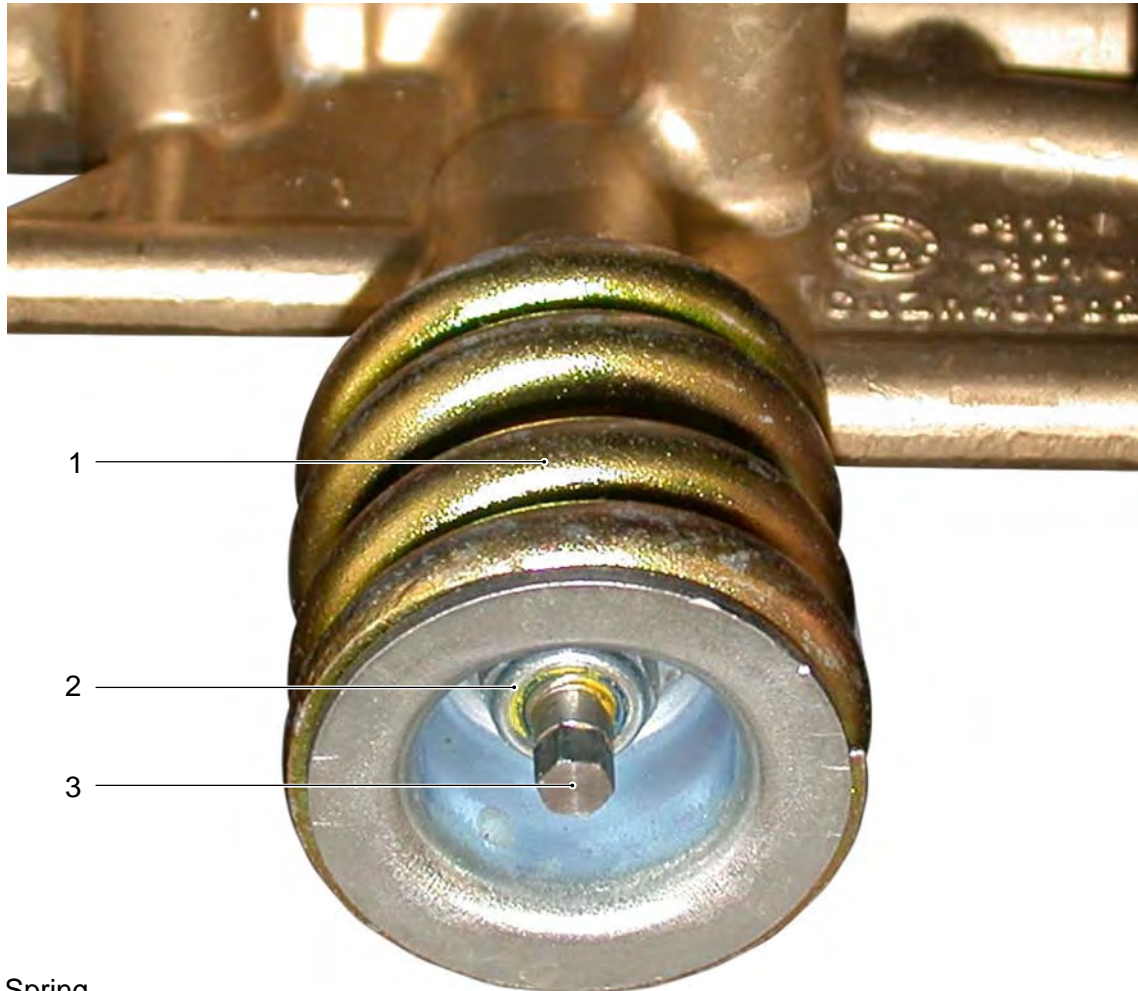

- 1 Spring
- 2 Adjusting nut, self-locking
- 3 Overflow valve spindle with hexagonal nut

Adjust the overflow valve at the handgun using the servo-press rotary control (standard accessory)

- Connect the testing pressure gauge with high-pressure hose and handgun with servo-press rotary control to the high-pressure outlet.
- Turn the servo-press rotary control to the **lowest** setting and let the unit run.
- Use the adjusting nut (2) to set the spring (1) pressure so that the overflow valve opening pressure is reached (see technical specifications).
- Switch off the unit and open the handgun to depressurise it.

Adjust the overflow valve in the standard handgun

- Adjust the testing pressure gauge with high-pressure hose and standard handgun to the high-pressure outlet. Insert the **new** high-pressure nozzle!
- Open the handgun and let the unit run.
- Use the adjusting nut (2) to set the spring (1) pressure so that the high-pressure operating pressure is reached (see technical specifications).
- Switch off the unit and open the handgun to depressurise it.

Troubleshooting

Fault	Measure
Unit is not running	<ul style="list-style-type: none"> - Check mains voltage, check/replace connection cable and mains fuse. - Check fuse (F1). - Check/replace unit switch (Q1). - Check/replace pressure switch (Q2).
Unit does not become pressurised	<ul style="list-style-type: none"> - Check/increase water supply volume. - Clean/replace water strainer. - Vent the unit. - Check/replace high-pressure nozzle. - Check pressure and suction valves for leaks/replace. - Check/adjust/replace overflow valve.
Unit constantly switches on and off when the handgun is closed	<ul style="list-style-type: none"> - Check handgun and O-rings at high-pressure connection for leaks/replace. - Check/replace cleaning agent non-return valve. - Check/adjust/replace overflow valve. - Check/replace non-return valve. - Check/replace pressure switch/control piston.
Unit does not switch off when handgun closed	<ul style="list-style-type: none"> - Check/adjust/replace overflow valve. - Check/replace non-return valve. - Check/replace pressure switch (Q2). - Check/replace pressure switch/control piston.
Cleaning agent is not sucked in	<ul style="list-style-type: none"> - Clean/replace cleaning agent non-return valve. - Check/replace cleaning agent nozzle. - Replace injector. - Clean/replace cleaning agent sieve. - Check/replace metering valve.
Water leak between cylinder head and piston housing	<ul style="list-style-type: none"> - Check/replace high-pressure and low-pressure seals.
Oil leak between cylinder head and piston housing	<ul style="list-style-type: none"> - Replace oil seals. - Check/replace piston.

Technical specifications

Unit type	Unit No.	Circuit Diagram	Operating instructions	Spare parts list
HD 6/16-4 M 230 V / 1 Ph / 50 Hz	1.524-100.0	0.089-003.0	5.961-712.0	5.970-406.0
HD 6/16-4 M Plus 230 V / 1 Ph / 50 Hz	1.524-107.0	0.089-003.0	5.961-712.0	5.970-406.0
HD 6/16-4 MX 230 V / 1 Ph / 50 Hz	1.524-101.0	0.089-003.0	5.961-712.0	5.970-406.0
HD 6/16-4 MX Plus 230 V / 1 Ph / 50 Hz	1.524-108.0	0.089-003.0	5.961-712.0	5.970-406.0
HD 7/18-4 M 400 V / 3 Ph / 50 Hz	1.524-200.0	0.087-804.0	5.961-712.0	5.970-409.0
HD 7/18-4 M Plus 400 V / 3 Ph / 50 Hz	1.524-208.0	0.087-804.0	5.961-712.0	5.970-4069.0
HD 7/18-4 MX 400 V / 3 Ph / 50 Hz	1.524-201.0	0.087-804.0	5.961-712.0	5.970-409.0
HD 7/18-4 MX Plus 400 V / 3 Ph / 50 Hz	1.524-211.0	0.087-804.0	5.961-712.0	5.970-409.0
HD 9/19 M 400 V / 3 Ph / 50 Hz	1.524-300.0	0.087-804.0	5.961-712.0	5.970-471.0
HD 9/19 M Plus 400 V / 3 Ph / 50 Hz	1.524-308.0	0.087-804.0	5.961-712.0	5.970-471.0
HD 9/19 MX 400 V / 3 Ph / 50 Hz	1.524-301.0	0.087-804.0	5.961-712.0	5.970-471.0
HD 9/19 MX Plus 400 V / 3 Ph / 50 Hz	1.524-311.0	0.087-804.0	5.961-712.0	5.970-471.0
HD 9/20-4 M *EU I 400 V / 3 Ph / 50 Hz	1.524-401.0	0.088-885.0	5.961-712.0	5.970-530.0
HD 9/20-4 M Plus *EU I 400 V / 3 Ph / 50 Hz	1.524-403.0	0.088-885.0	5.961-712.0	5.970-530.0
HD 9/20-4 MX Plus *EU I 400 V / 3 Ph / 50 Hz	1.524-404.0	0.088-885.0	5.961-712.0	5.970-530.0
HD 9/20-4 M *EU II 230 V / 3 Ph / 50 Hz	1.524-402.0	0.088-885.0	5.961-712.0	5.970-530.0

The technical data sheet and the circuit diagram will be included in the next issue of the spare parts CD-ROM (DISIS) and are available in kaercher-inside (<https://kaercher-inside.com>).

Special Tools

Multimeter	6.803-022
Mounting mandrel high-pressure /oil seal HD 6/16	2.901-031
Mounting mandrel high-pressure /oil seal HD 7/18	2.901-033
Appropriate tools for HD 9/19	
Strike mandrel high-pressure /oil seal HD 9/20	5.901-05
Mounting sleeve high-pressure /oil seal HD 9/20	5.901-182
Assembly/dismantling tool - overflow valve seat	4.901-054
Valve pliers	4.901-062
Shut-off valve	4.580-034
Testing pressure gauge	4.742-025

Tightening torques

Cylinder head screws	40-45 Nm
Piston housing	5-7 Nm
Handgun, pressure control	40 Nm
Pressure valves, threaded connection	40-45 Nm
Pressure switch, threaded connection	15-17 Nm
Suction valves - threaded connection	35-40 Nm
Overflow valve seat	8-10 Nm
Swash plate	9-12 Nm
Motor housing	9-12 Nm
Overflow valve, threaded connection	30-35 Nm
Cleaning agent injector	1.5-2.5 Nm
Suction cover, threaded connection	12-15 Nm
Fan wheel, threaded connection	9-12 Nm