

CV 38/2
CV 48/2
Service Manual



Contents

1	Preface	3
2	Safety instructions	3
3	Technical Features	3
4	Parts of the system	4
5	Basic settings and service procedures	5
6	Maintenance and care	8
7	Troubleshooting	11
8	Technical specifications	13
9	Circuit diagram	14

1 Preface

Good service work requires extensive and practice-oriented training as well as well-structured training materials.

Hence we offer regular basic and advanced training programmes covering the entire product range for all service engineers.

In addition to this, we also prepare service manuals for important appliances - these can be initially used as instruction guides and later on as reference guides.

Apart from this, we also regular information about product enhancements and their servicing.

If you should require supplements, have corrections or questions regarding this document, please address these citing the following subject to:

international-service@de.kaercher.com

Subject:	Fall 108579
----------	--------------------

The responsible product specialist will take care of your issue.

Copying and duplication of texts and diagrams as well as third-party access to this information is permitted only with the explicit permission of the company:

Alfred Kärcher GmbH & Co. KG

P O Box 160

D - 71349 Winnenden

www.kaercher.com

2 Safety instructions

2.1 Hazard levels

⚠ Danger

Immediate danger that can cause severe injury or even death.

⚠ Warning

Possible hazardous situation that could lead to severe injury or even death.

Caution

Possible hazardous situation that could lead to mild injury to persons or damage to property.

3 Technical Features

Structure:

- Two-motoric brush vacuum
- Height adjustable handle
- The height of the brush head can be adjusted to match the pile height of the carpet (with indicator lamp).
- 3-fold filter: Dust filter (fleece filter), motor protection filter, exhaust filter
- Filter filling display
- CV 38/2: Working width 335 mm (13.2 in.)
- CV 48/2: Working width 430 mm (16.9 in.)

Drive:

- Suction turbine (blower motor)
- The second motor drives the brush roller by means of a toothed gear (brush motor).

4 Parts of the system

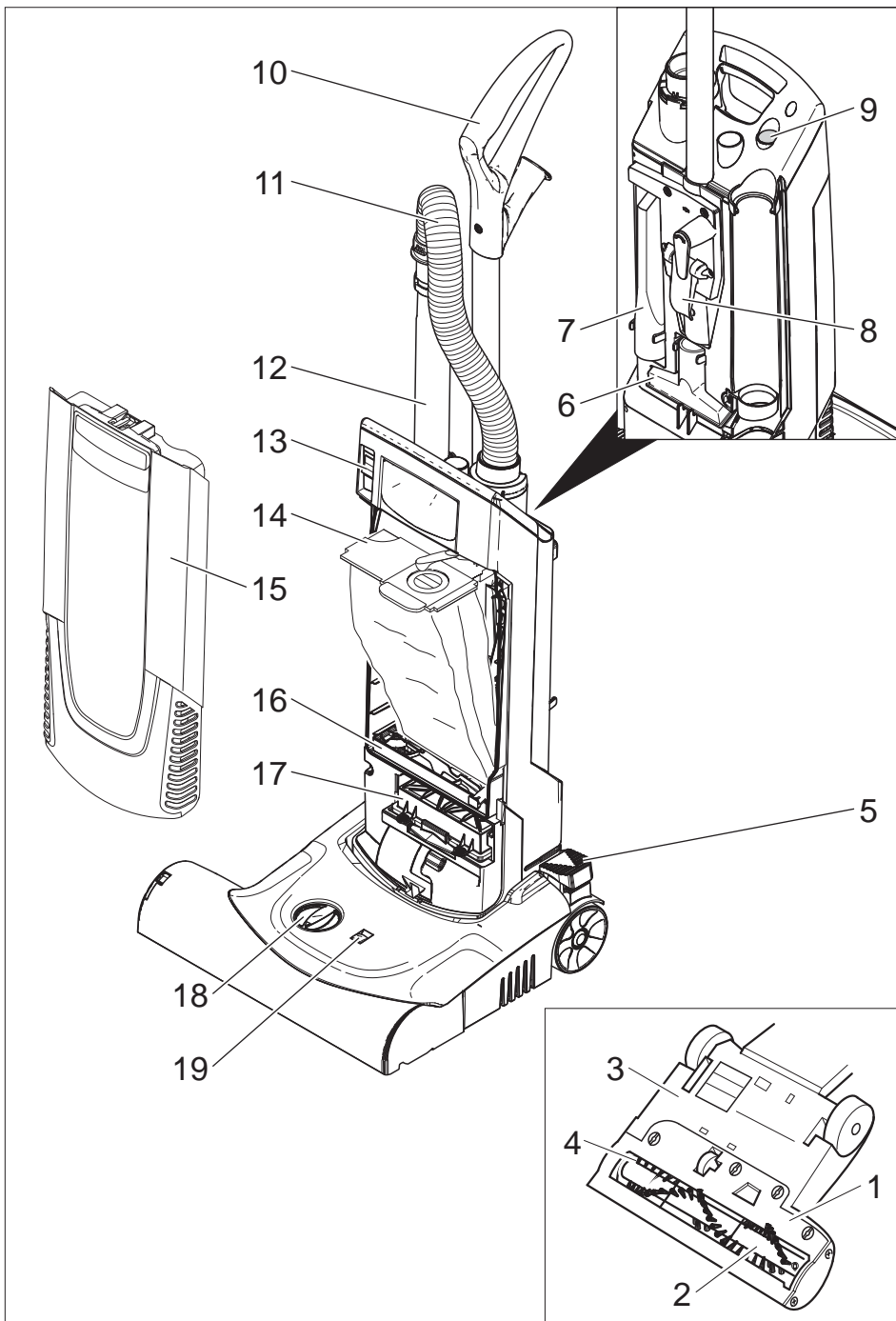

- | | | | |
|----|--|----|--|
| 1 | Brush cover | 18 | Pile height adjustment knob
(Standard series in position 2) |
| 2 | Brush | 19 | Indicator lamp - Electronic brush control (orange) |
| 3 | Brush head | | |
| 4 | Indicator bundle
(CV 38/2 only) | | |
| 5 | Unlocking brushg head | | |
| 6 | Upholstery nozzle | | |
| 7 | Crevice nozzle | | |
| 8 | Handle adjustment | | |
| 9 | Indicator lamp on the filter housing (red) | | |
| 10 | Handle | | |
| 11 | Suction hose | | |
| 12 | Suction pipe | | |
| 13 | Power switch | | |
| 14 | Filter bag | | |
| 15 | Filter cover | | |
| 16 | Motor filter | | |
| 17 | Blower filter | | |

5 Basic settings and service procedures

5.1 Replace the cable hook or the handle adjustment



- 1 Fastening screws for rear cover
- 2 Cable hook
- 3 Handle adjustment
- 4 Rear cover

- ➔ Unscrew locking screws.
- ➔ Remove rear cover.
- ➔ Replace the cable hook or the handle adjustment.
- ➔ Install the new cable hook or a new handle adjustment in reverse sequence.

5.2 Remove top cover.

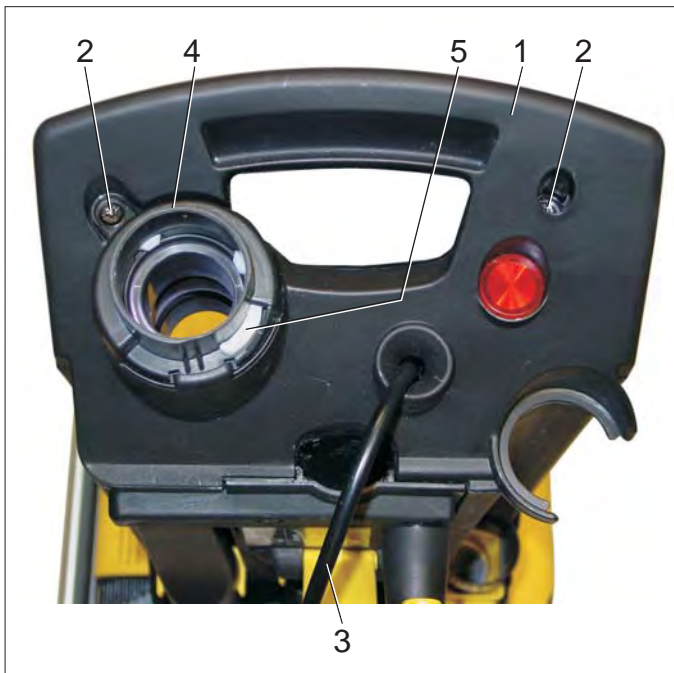

- 1 Top cover
 - 2 Fastening screws for top cover
 - 3 Power cord
 - 4 Suction hose connection
 - 5 Safety ring
- ➔ Unscrew locking screws.

- ➔ Remove top cover.

5.3 Replace washer ring

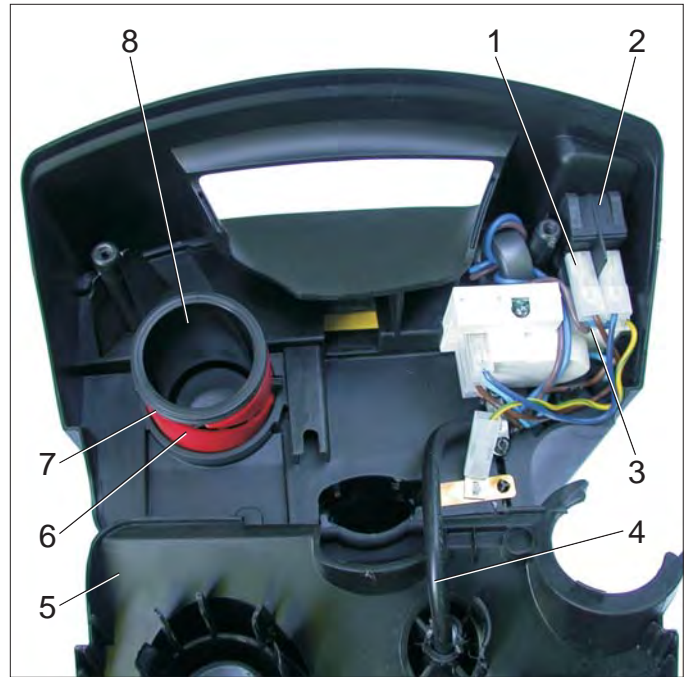

- 1 Connection plug of the mains cable
 - 2 Power switch
 - 3 Connection plug of the circuit board
 - 4 Power cord
 - 5 Top cover
 - 6 Ring
 - 7 Washer ring
 - 8 Suction hose connection neck
- ➔ Remove washer ring.
- ➔ Insert new washer ring.

5.4 Replacing the mains cable

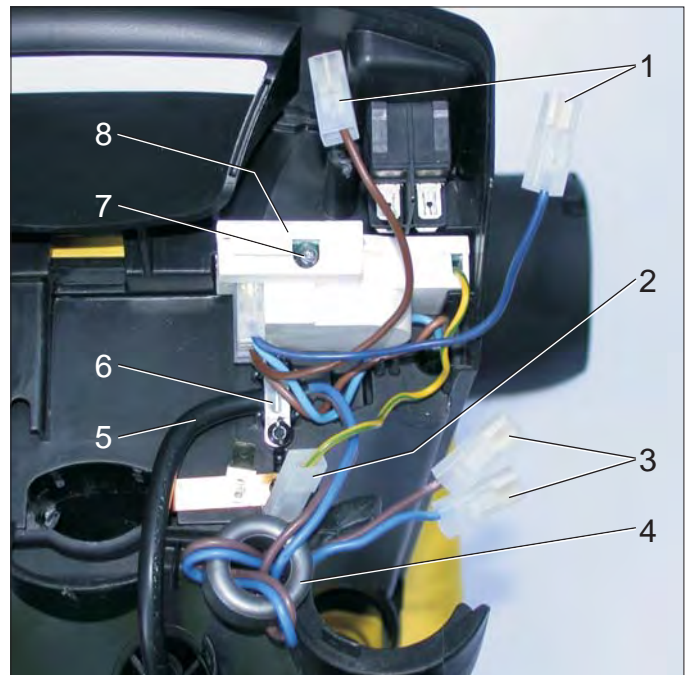

- 1 Connection plug of the circuit board
- 2 Connection plug of the earth cable (protective conductor)
- 3 Connection plug of the mains cable
- 4 Ferrit ring (anti-interference ring)
- 5 Power cord
- 6 Clamp for mains cable
- 7 Indicator lamp
- 8 Suction hose connection neck

8 Circuit board with casing

- Pull the connection plug of the mains cable off the appliance switch (top).
- Remove the clamp.
- Remove the mains cable from the cable guide.
- Install the new mains cable in reverse sequence.

5.5 Replace the circuit board

The low pressure sensor on the printed circuit board measures the vacuum in the suction system. With rising vacuum pressure (filter bag is full), the indicator lamp glows. If the circuit board is defective, it must be replaced including the casing.

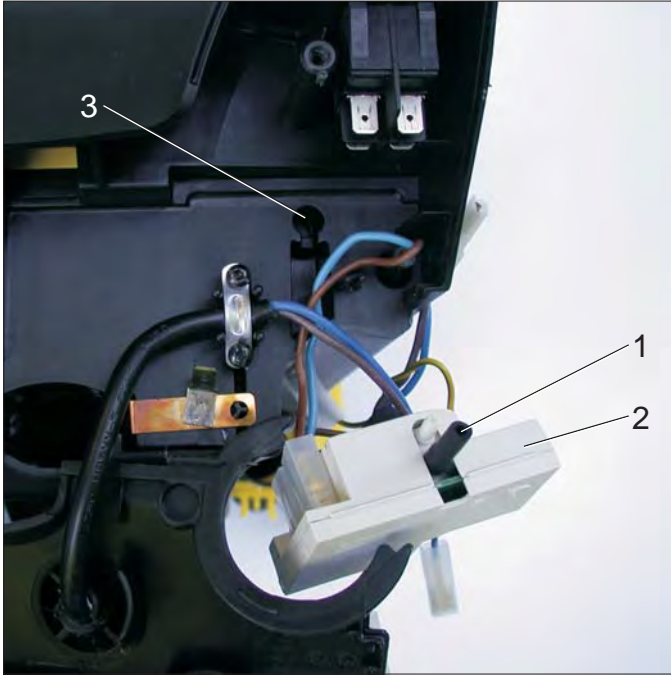

- 1 Vacuum hose of the circuit board
- 2 Circuit board with casing
- 3 Connection for vacuum hose

- Pull the connection plug of the circuit board off the appliance switch (bottom).
- Remove the connection plug of the earth cable (protective conductor)
- Remove the circuit board.
- Install the new circuit board in reverse sequence.

Note: When installing the circuit board with casing, make sure that the vacuum hose is properly connected to the connection.

5.6 Removing the brush head cover

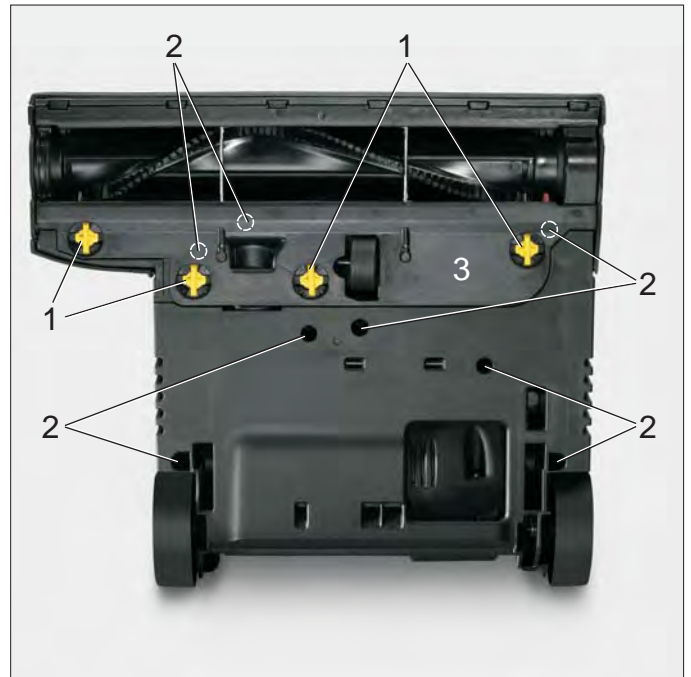

- 1 Lock the journal for the slide plate
- 2 Fastening screws for brush head cover
- 3 Slide plate
- Turn the lock journal by 90° in anti-clock-wise direction.
- Fold the slide plate up and remove it.
- Unscrew locking screws.

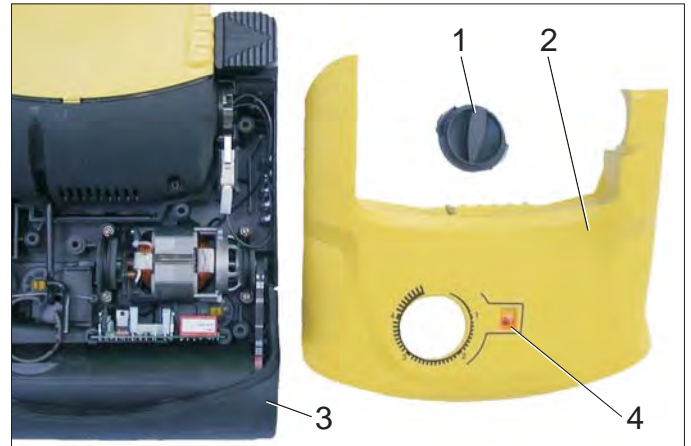

- 1 Pile height adjustment knob
- 2 Brush head cover
- 3 Brush head
- 4 Indicator lamp - Electronic brush control (orange)
- Remove the pile height adjustment knob
- Remove the brush head cover.

5.7 Replace the brush motor

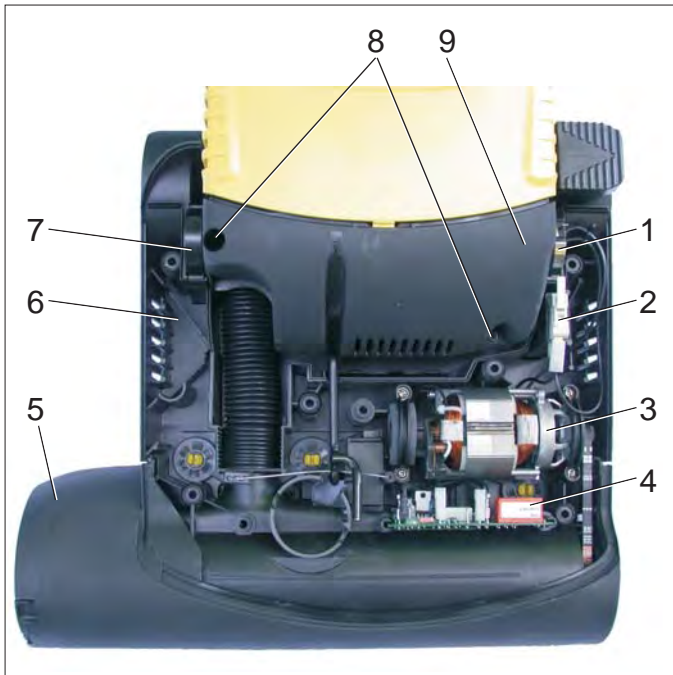

- 1 Switch cam
- 2 Brush motor switch
- 3 Brush motor
- 4 Brush motor electronics
- 5 Safety bumper
- 6 Brush head casing
- 7 Bearing bowl incl. spring clamp
- 8 Fastening screws of the casing top
- 9 Housing top

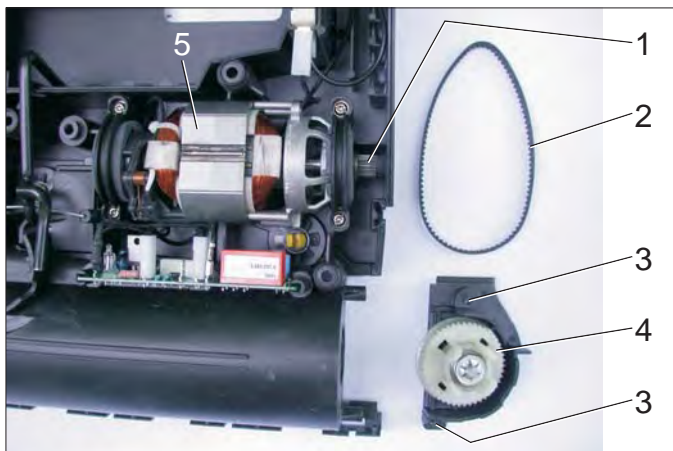

- 1 Drive pinions of the brush motor
 - 2 Drive belt
 - 3 Fastening screws of the drive bearing
 - 4 Drive bearing of the brush
 - 5 Brush motor
- Unscrew locking screws.
 - Pull out the drive bearing.
 - Remove the drive belt.
 - Remove the brush motor.
 - Install the new brush motor in reverse sequence.
 - As required: Clean the inside of the indicator lamp cover (orange) of the brush head cover of carbon brush residue.

5.8 Pile height adjustment

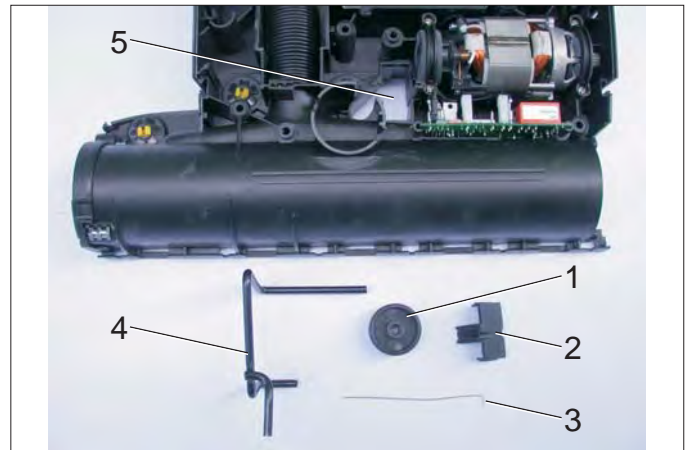

- 1 Impeller
- 2 Impeller cover
- 3 Steel spring
- 4 Metal clip
- 5 Opening of impeller

5.9 Replacing the suction turbine



- 1 Filter cover
 - 2 Bearing locations
 - 3 Filter casing
- Lift up the complete filter casing and remove it from the bearing locations.
 - Remove the filter cover.

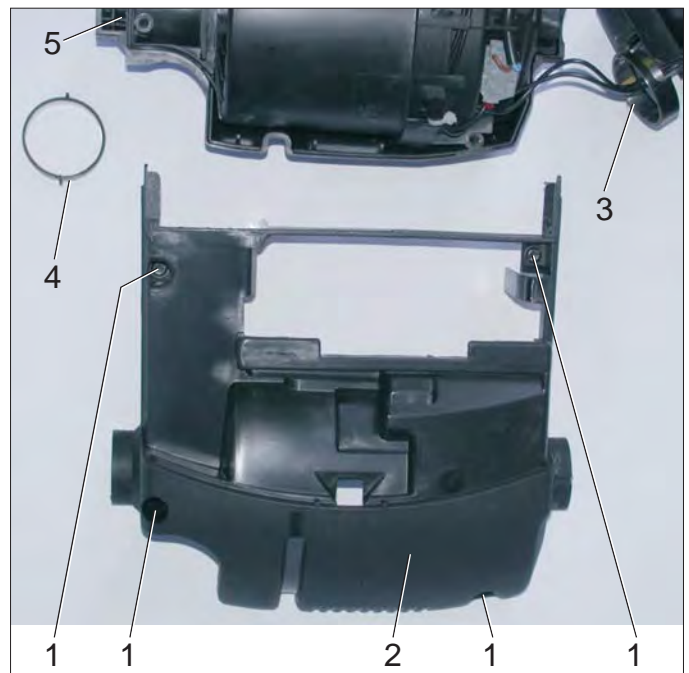

6 Maintenance and care

- 1 Fastening screws of the casing top
 - 2 Housing top
 - 3 Bearing bowl incl. spring clamp and switch cams
 - 4 Bearing bowl incl. spring clamp
- ➔ Pull the bearing bowls off to the side.
 - ➔ Unscrew locking screws.
 - ➔ Remove the top part of the casing.

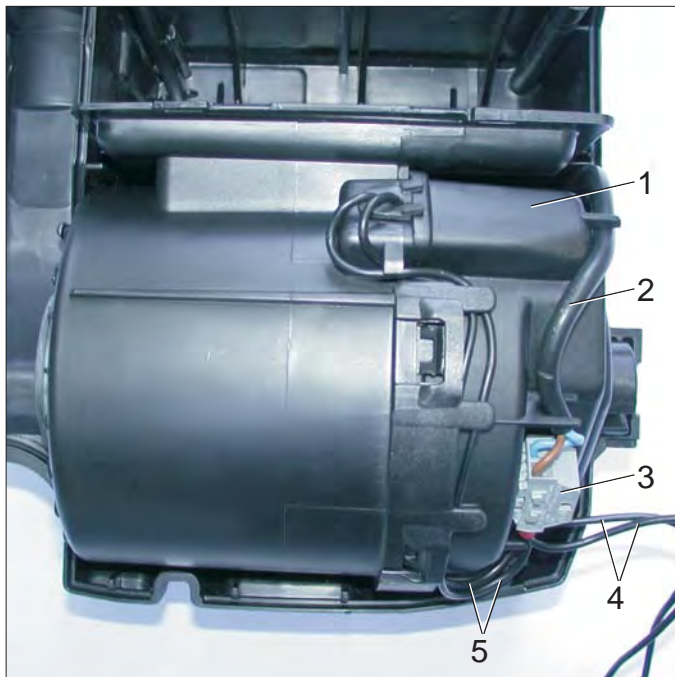
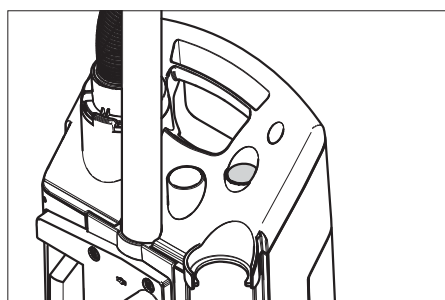
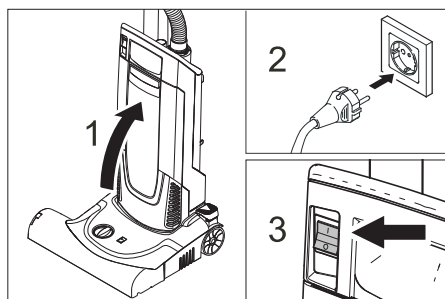
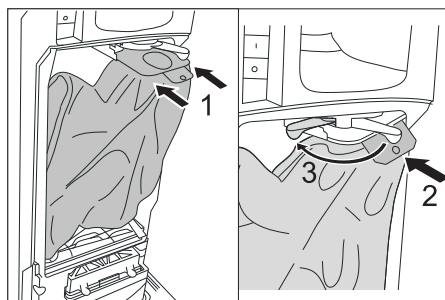
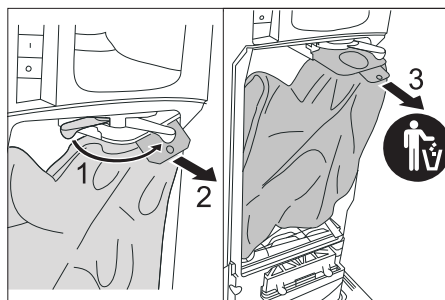
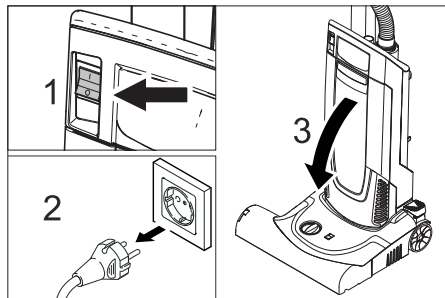
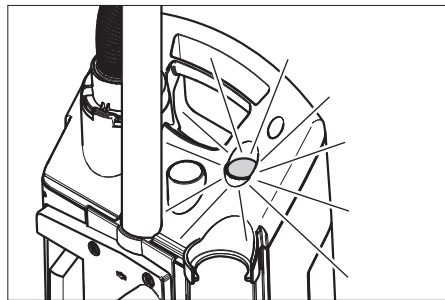

- 1 Suction turbine
 - 2 Power cord
 - 3 Terminal strip of the suction turbine
 - 4 Connection cable to the brush head
 - 5 Connection cable of the suction turbine
- ➔ Remove the suction turbine.
 - ➔ Pull the connecting cable of the suction turbine out of the terminal strip.
 - ➔ Install the new suction turbine in reverse sequence.

Note: The mains cable must be routed as shown in the illustration within the respective pins (see arrows).

5.10 Replace seal

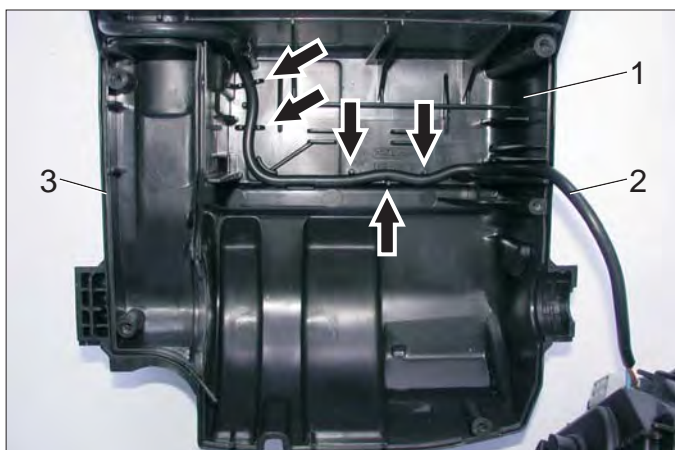

- 1 Casing bottom
 - 2 Power cord
 - 3 Seal
- ➔ Remove the seal.
 - ➔ Insert new seal.
- Note:** The seal must be placed precisely into the guide groove of the casing bottom to protect the suction turbine from contamination.

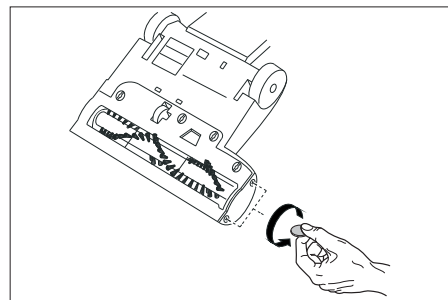
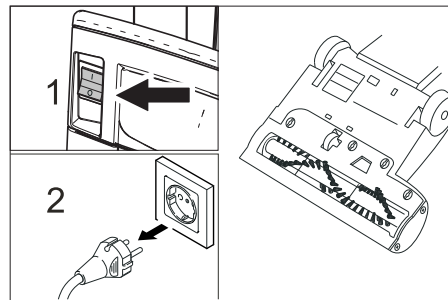
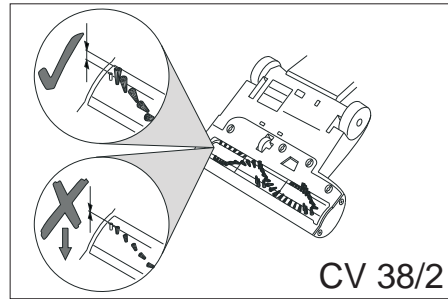
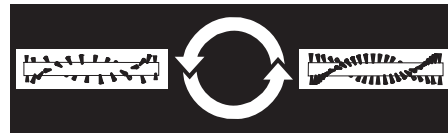
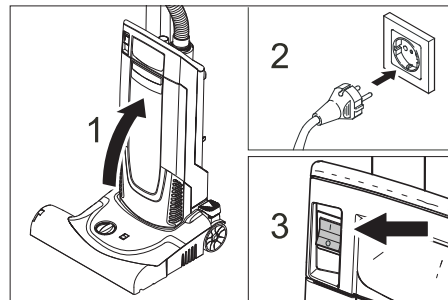
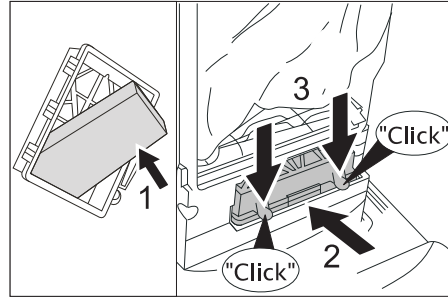
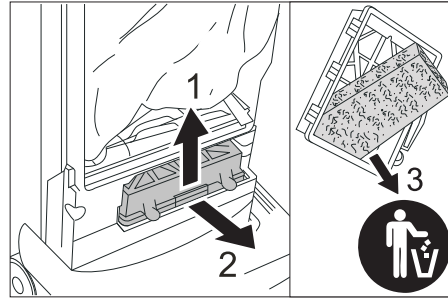
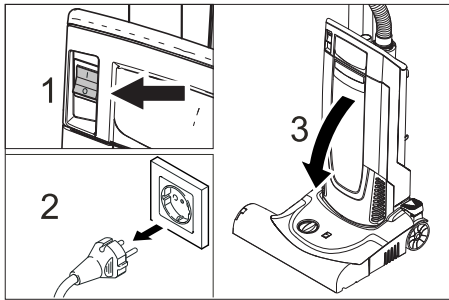
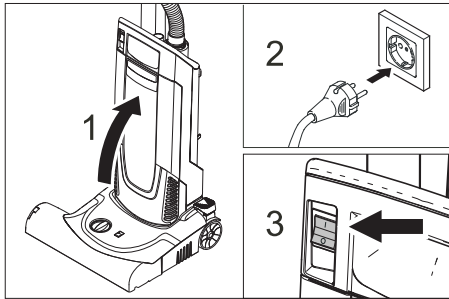
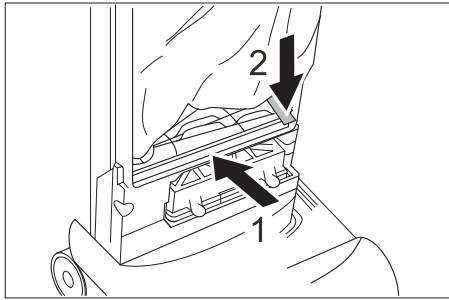
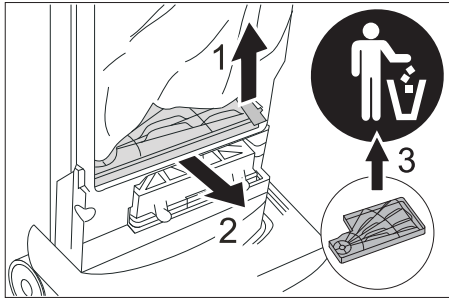
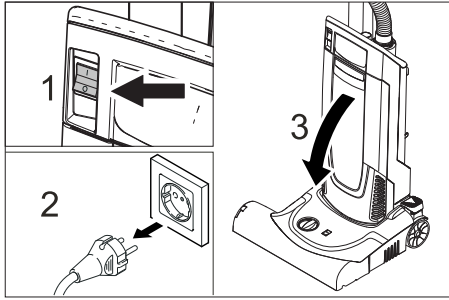

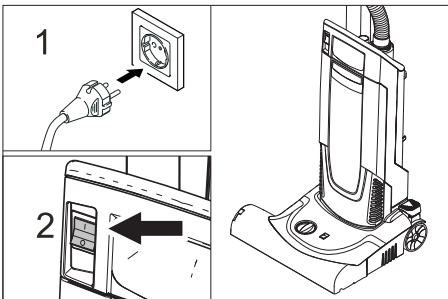
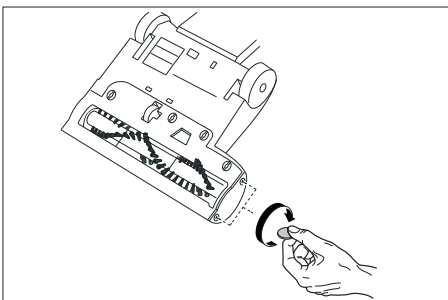
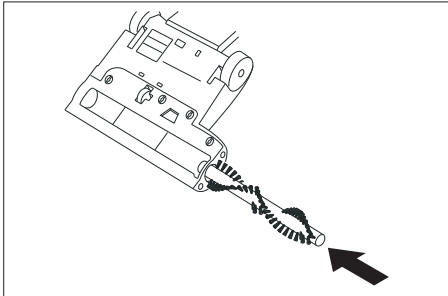
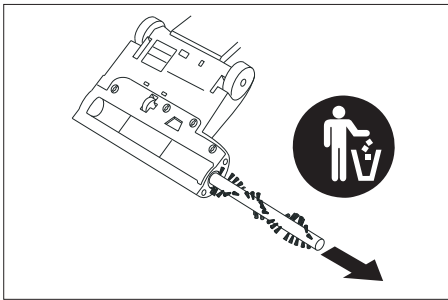

7 Troubleshooting

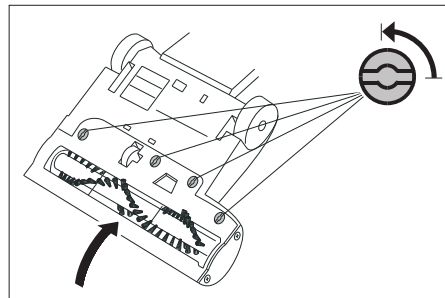
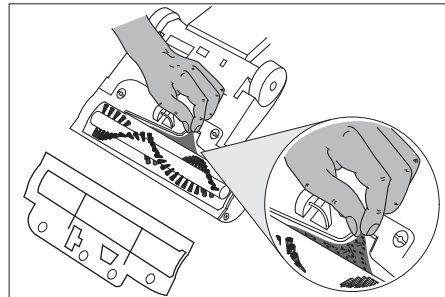
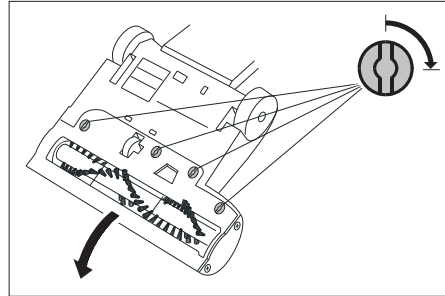
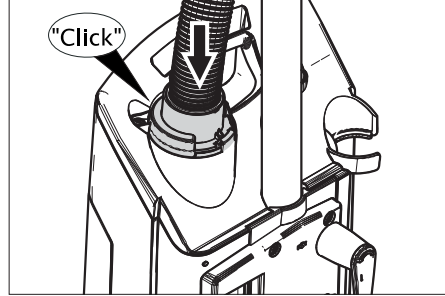
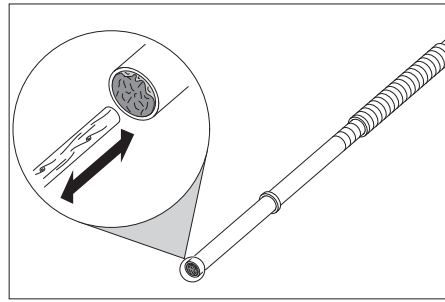
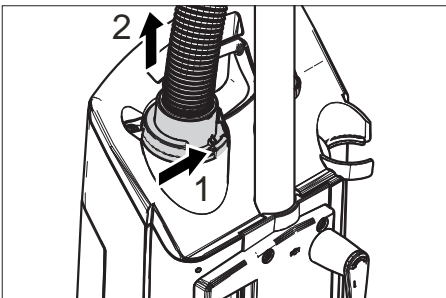
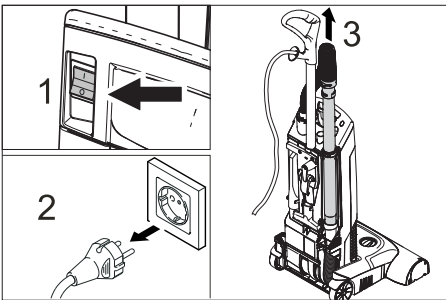
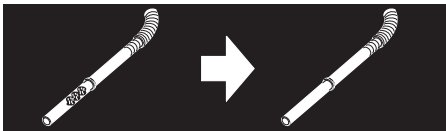
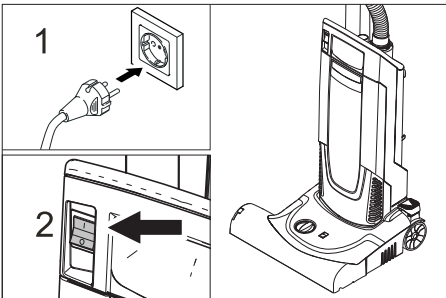
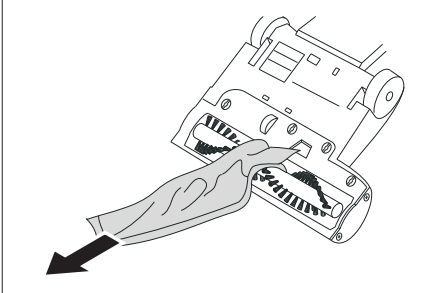
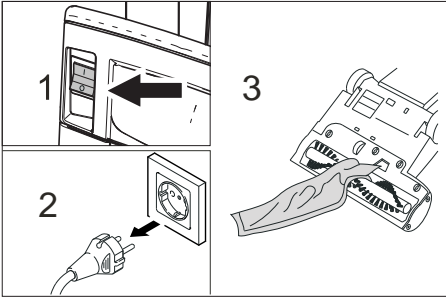
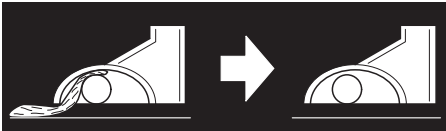

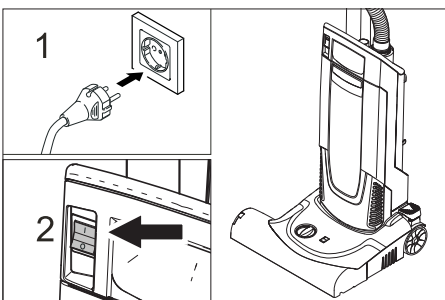
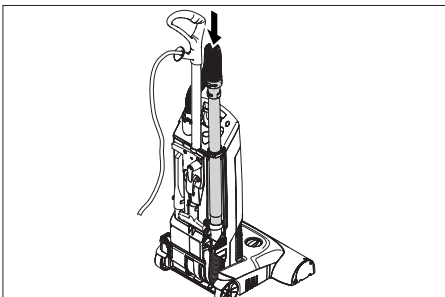
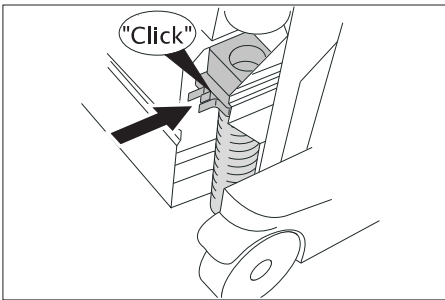
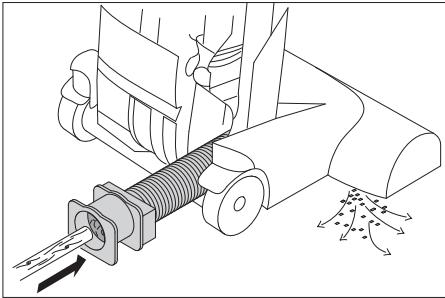
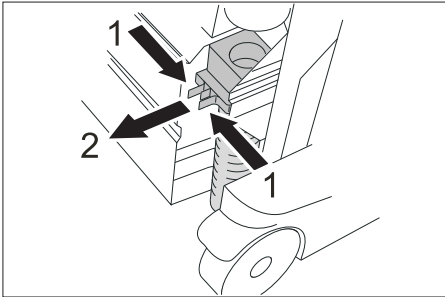
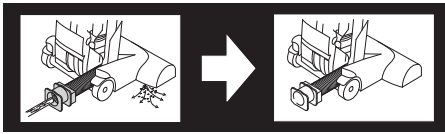

7.1 Motor does not run

- No electrical voltage.
- Check cables, plugs, fuse, and socket.
- Thermostat switched off the motor because of overheating
- Pull mains plug, replace blocked filters, or remove blockage from the suction hose.

The unit is operational again after it has cooled down.

7.2 Unsatisfying suction result

- Check the brush for blocking objects.
- Remove obstructions from brush head, suction pipe and suction hose.
- Replace the filter bag.
- Replace blower filter and motor protection filter.
- Check the pile height adjustment knob for correct adjustment.
- CV 38/2 only: The brush must be replaced when it is worn out. The degree of wear is shown by a comparison with the indicator bundle of a different colour. The brush must be replaced when the black bristles are at the same level as the red ones.

7.3 The red indicator lamp on the filter housing is ON

- Remove obstructions from brush head, suction pipe and suction hose.
- Replace the filter bag.

7.4 The orange indicator lamp - Electronic brush control is ON

- Set the adjustment knob for pile height to the lower pile height.

7.5 The orange indicator lamp - Electronic brush control is also ON at lowest level

- Replace brush.

8 Technical specifications

Appliance type	Appliance no.:	Circuit diagram	Operating instructions	Spare parts list
CV38/2 EU, 220-240 V, 1~ 50/60 Hz	1.033-315.0	0.089-192.0	5.962-949.0	5.970-967.0
CV 38/2 GB, 220-240 V, 1~ 50/60 Hz	1.033-316.0	0.089-192.0	5.962-949.0	5.970-967.0
CV 38/2 AU, 240 V, 1~ 50/60 Hz	1.033-317.0	0.089-192.0	5.962-949.0	5.970-967.0
CV 38/2 USA, 120 V, 1~ 60 Hz	1.033-318.0	0.089-205.0	5.963-274.0	5.971-026.0
CV 48/2 EU, 220-240 V, 1~ 50/60 Hz	1.057-310.0	0.089-192.0	5.962-949.0	5.970-967.0
CV 48/2 GB, 220-240 V, 1~ 50/60 Hz	1.057-311.0	0.089-192.0	5.962-949.0	5.970-967.0
CV 48/2 AU, 240 V, 1~ 50/60 Hz	1.057-312.0	0.089-192.0	5.962-949.0	5.970-967.0
CV 48/2 USA, 120 V, 1~ 60 Hz	1.057-313.0	0.089-205.0	5.963-274.0	5.971-026.0

The technical specification sheet and the circuit diagram will be included in the next version of the spare parts CD (DISIS) and in the Intranet.

- Technical specification sheet:
Folder "Central / Service Info Int'l / Technical Specifications"
- Circuit diagram:
Folder "Central / Service Info Int'l / Circuit Diagram"

The operating instructions and the spare parts list can be requested in paper form with the respective part numbers from our spare parts service department.

8.1 Special tools

There are no special tools necessary.

8.2 Tightening torques

No data.

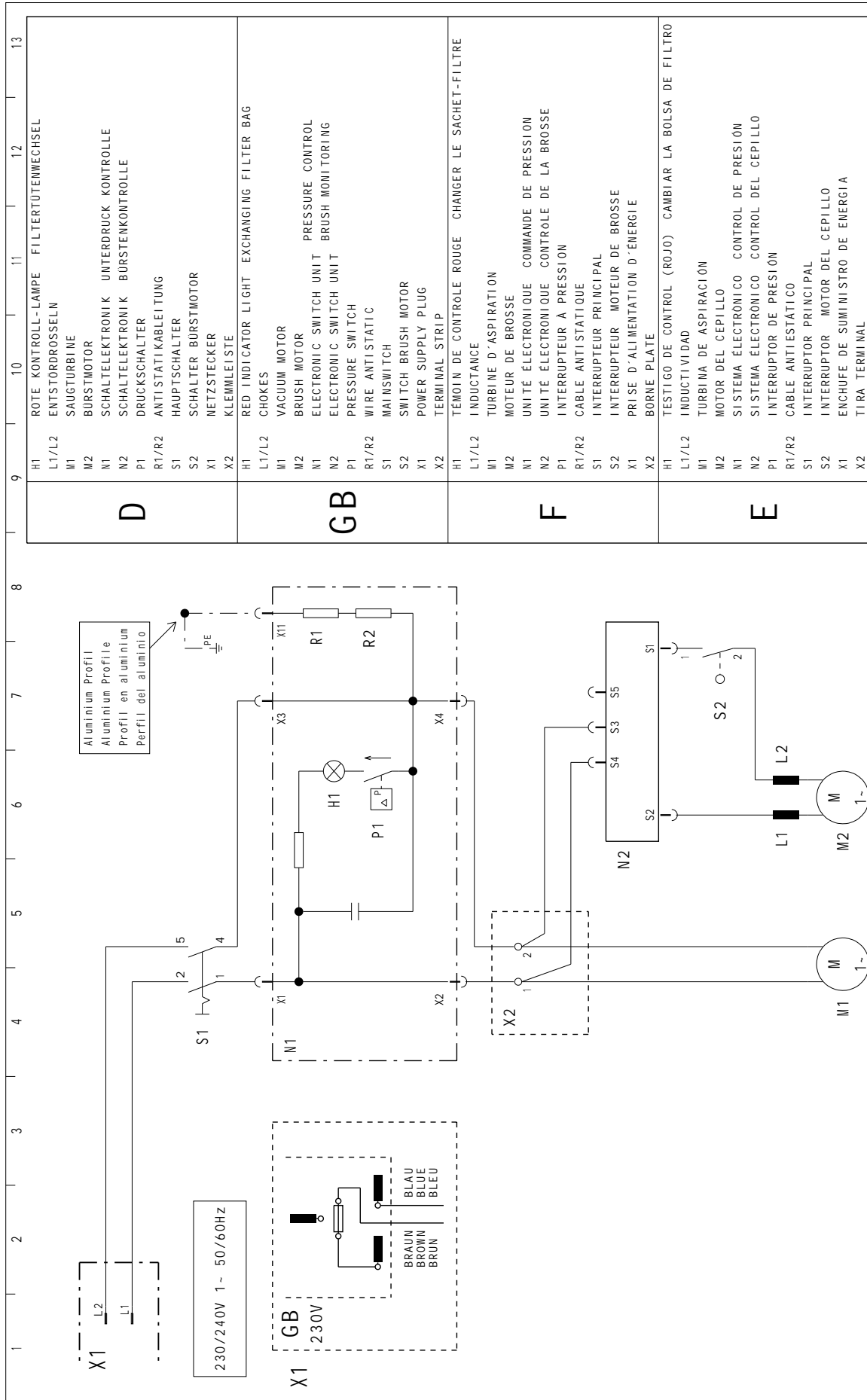

9	10	11	12	13
D	H1 L1/L2 M1 M2 N1 N2 P1 R1/R2 S1 S2 X1 X2	ROTE KONTROLL-LAMPE ENTSTORDBSELN SAUGTURBINE BURSTMOTOR SCHALTELEKTRONIK UNTERDRUCK KONTROLLE SCHALTELEKTRONIK BURSTENKONTROLLE DRUCKSCHALTER ANTI STATIKABLEITUNG HAUPTSCHALTER SCHALTER BURSTMOTOR NETZSTECKER KLEMMLEISTE	FILTERTUTENWECHSEL	
GB	H1 L1/L2 M1 M2 N1 N2 P1 R1/R2 S1 S2 X1 X2	RED INDICATOR LIGHT EXCHANGING FILTER BAG CHOKES VACUUM MOTOR BRUSH MOTOR ELECTRONIC SWITCH UNIT PRESSURE CONTROL ELECTRONIC SWITCH UNIT BRUSH MONITORING PRESSURE SWITCH WIRE ANTI STATIC MAINSWITCH SWITCH BRUSH MOTOR POWER SUPPLY PLUG TERMINAL STRIP		
F	H1 L1/L2 M1 M2 N1 N2 P1 R1/R2 S1 S2 X1 X2	TEMOIN DE CONTRÔLE ROUGE CHANGER LE SACHET-FILTRE INDUCTANCE TURBINE D'ASPIRATION MOTEUR DE BROSE UNITÉ ELECTRONIQUE COMMANDE DE PRESSION UNITÉ ELECTRONIQUE CONTRÔLE DE LA BROSE INTERRUPTEUR A PRESSION CABLE ANTI STATIQUE INTERRUPTEUR PRINCIPAL INTERRUPTEUR MOTEUR DE BROSE PRISE D'ALIMENTATION D'ENERGIE		
E	H1 L1/L2 M1 M2 N1 N2 P1 R1/R2 S1 S2 X1 X2	TESTIGO DE CONTROL (ROJO) CAMBIAR LA BOLSA DE FILTRO INDUCTIVIDAD TURBINA DE ASPIRACION MOTOR DEL CEPILLO SISTEMA ELECTRONICO CONTROL DE PRESSION SISTEMA ELECTRONICO CONTROL DEL CEPILLO INTERRUPTOR DE PRESSION CABLE ANTIESTATICO INTERRUPTOR PRINCIPAL INTERRUPTOR MOTOR DEL CEPILLO ENCHUFE DE SUMINISTRO DE ENERGIA TIRA TERMINAL		

Datum date 18.02.09	GEPR. draft date	check desin.	stand. verif.	NORM SMD-W	ANZ. no. 0	AND./FR. changer/rel. no. 2018352	ERS F. exch. of empl.	Dok-Nr. doc-no. 5190952	Dok-Vers. doc-vers. 00	ANLAGE = SLP plant instal. order no.	ORT location lieu	Winnenden	BENENNUNG Stromaufplan identification circuit diagram plan de circuit Bessin No.	ZEICHNUNGS-NR. drawing-no. 0.089-192.0
	urB	fma			0			5190952	00	ANFRAG order no.		Winnenden	ANLAGE-REZ plant design denomin.	BLATTZ. page tot. 1

File: CV382_CV482_EU

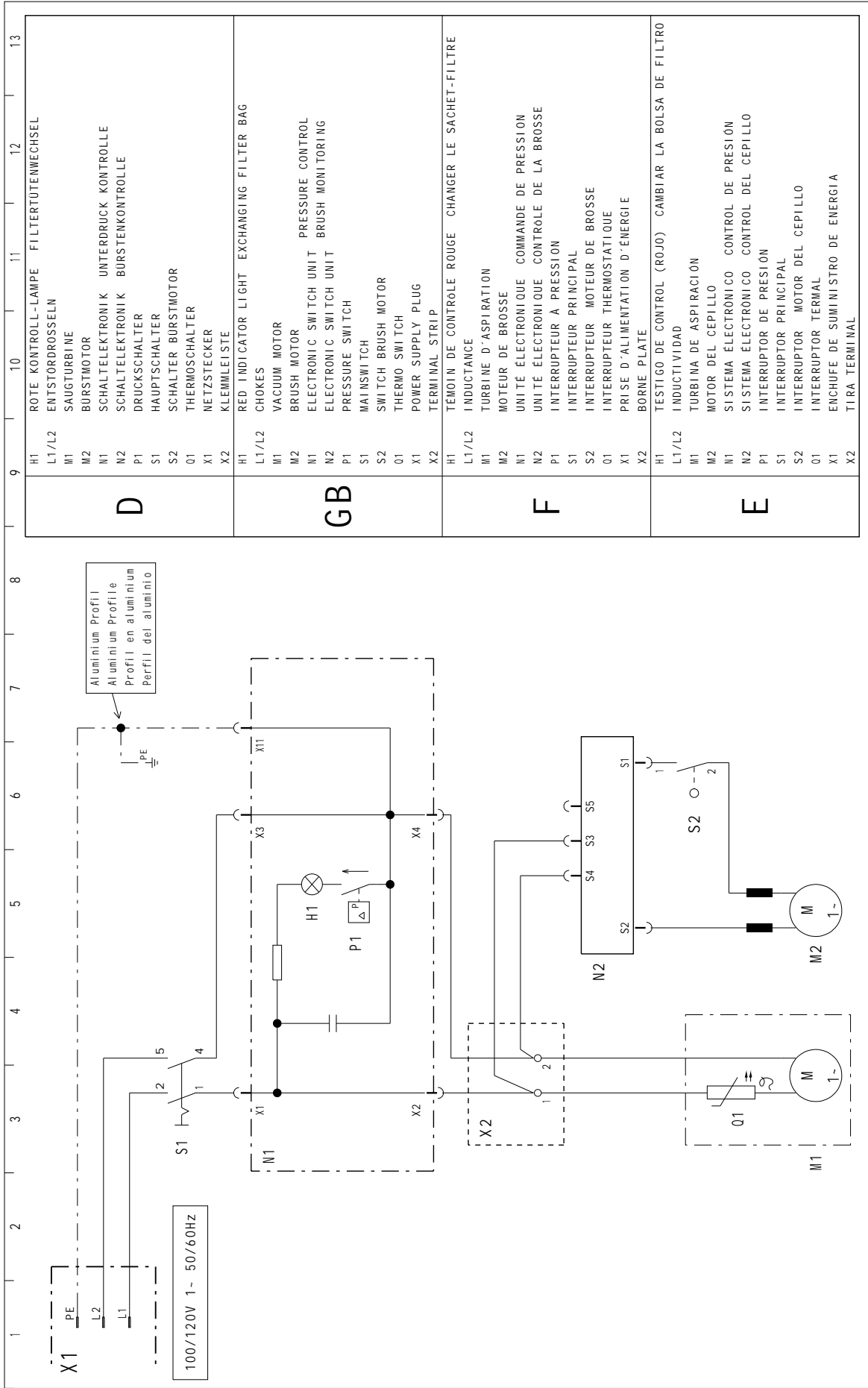

D

H1 ROTE KONTROLL-LAMPE FILTERTÜTENWECHSEL
 L1/L2 ENTSTÖRDROSSELN
 M1 SAUGTURBINE
 M2 BURSTMOTOR
 N1 SCHALTELEKTRONIK UNTERDRUCK KONTROLLE
 M2 SCHALTELEKTRONIK BURSTENKONTROLLE
 P1 DRUCKSCHALTER
 S1 HAUPTSCHALTER
 S2 SCHALTER BURSTMOTOR
 O1 THERMOSCHALTER
 X1 NETZSTECKER
 X2 KLEMMLEISTE

GB

H1 RED INDICATOR LIGHT EXCHANGING FILTER BAG
 L1/L2 CHOKES
 M1 VACUUM MOTOR
 M2 BRUSH MOTOR
 N1 ELECTRONIC SWITCH UNIT
 M2 ELECTRONIC SWITCH UNIT
 P1 PRESSURE SWITCH
 S1 MAINSWITCH
 S2 SWITCH BRUSH MOTOR
 O1 THERMO SWITCH
 X1 POWER SUPPLY PLUG
 X2 TERMINAL STRIP

F

H1 TÉMOIN DE CONTRÔLE ROUGE CHANGER LE SACHET-FILTRE
 L1/L2 INDUCTANCE
 M1 TURBINE D'ASPIRATION
 M2 MOTEUR DE BROSSÉ
 N1 UNITÉ ÉLECTRONIQUE COMMANDE DE PRESSION
 M2 UNITÉ ÉLECTRONIQUE CONTRÔLE DE LA BROSSÉ
 P1 INTERRUPTEUR À PRESSION
 S1 INTERRUPTEUR PRINCIPAL
 S2 INTERRUPTEUR MOTEUR DE BROSSÉ
 O1 INTERRUPTEUR THERMOSTATIQUE
 X1 PRISE D'ALIMENTATION D'ÉNERGIE
 X2 BORNE PLATE

E

H1 TESTIGO DE CONTROL (ROJO) CAMBIAR LA BOLSA DE FILTRO
 L1/L2 INDUCTIVIDAD
 M1 TURBINA DE ASPIRACION
 M2 MOTOR DEL CEPILLO
 N1 SISTEMA ELECTRONICO CONTROL DE PRESSION
 M2 SISTEMA ELECTRONICO CONTROL DEL CEPILLO
 P1 INTERRUPTOR DE PRESSION
 S1 INTERRUPTOR PRINCIPAL
 S2 INTERRUPTOR MOTOR DEL CEPILLO
 O1 INTERRUPTOR TERMAL
 X1 ENCHUFE DE SUMINISTRO DE ENERGIA
 X2 TIRA TERMINAL

Datum date	18.02.09	GEZ. draft	draht	check writ.	NORM stand.	A-IND. ch-ind	ANZ. no.	ANZ. no.	Änd./FR. change/rel.	ERS.F. exch. of repl.	Dok.-Nr. doc-no.	5194512	Dok-VERS. doc-vers.	00	ANLAGE = SLP plant installat.	AUFTRAG order no.	ORT + S location free	BEZEICHNUNG identification	Stromlaufplan circuit diagram	ZEICHNUNGS-NR. drawing-no.	0.089-205		
File: CV382_CV482_US																		ANLAG.-BEZ. plant desig.	plan de circuit	DESIGN NO.			
																		ANLAG.-BEZ. plant desig.	CV382/2	CV482/2	US		
																		BLATT page	1	BLATT page	1		
																		denomin.				page tot. page tot.	1