

# 22 Piston

Professional \ High pressure cleaner hotwater \ Electric motor \ HDS 8/17 C \*EU-II \ Spare parts list HDS 8/17 C \*EU-II \ Pump set \ Piston

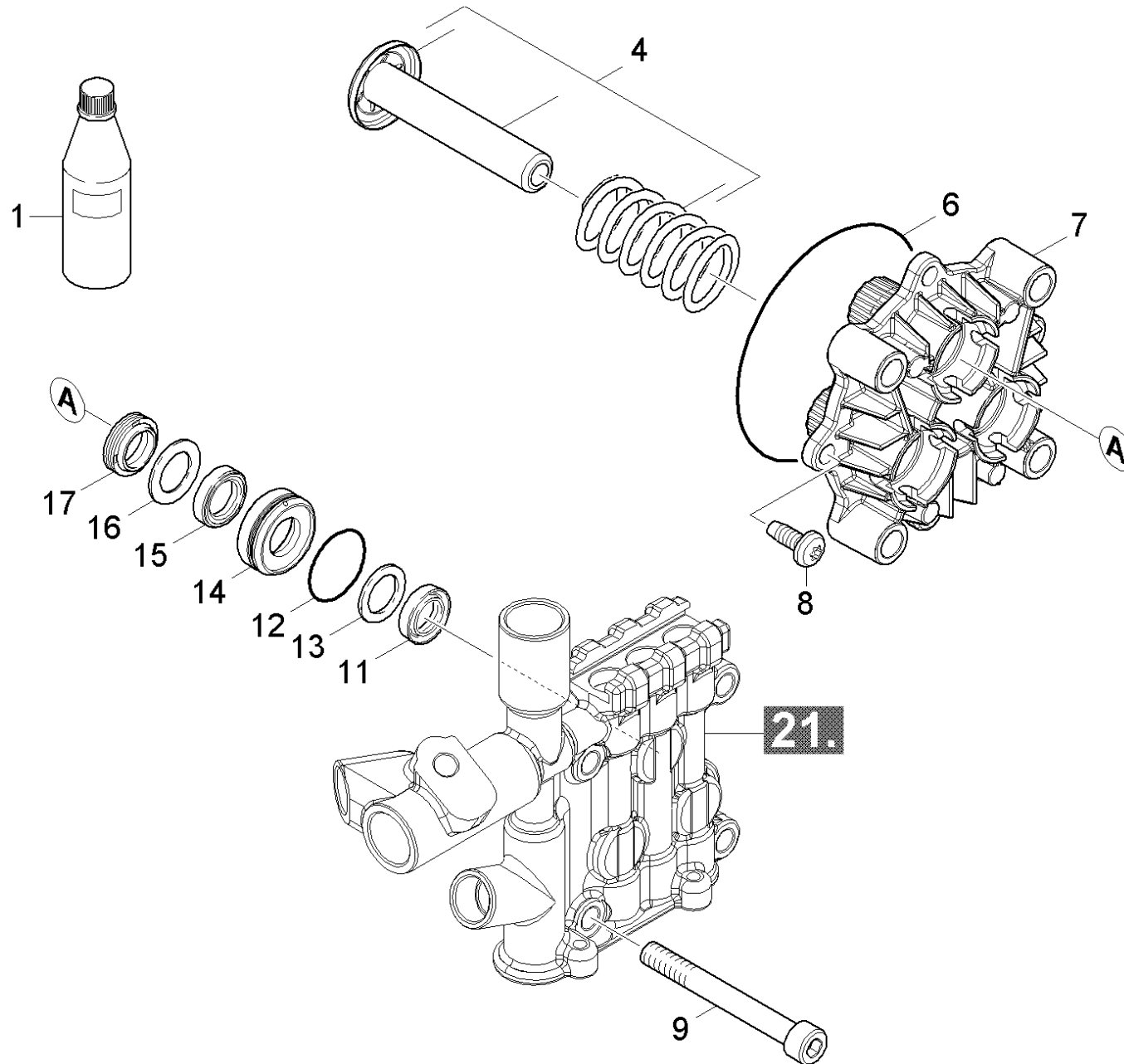

## 22 Piston

Professional \ High pressure cleaner hotwater \ Electric motor \ HDS 8/17 C \*EU-II \ Spare parts list HDS 8/17 C \*EU-II \ Pump set \ Piston

**KÄRCHER**

POS	Article no.	Description	Quantity	Unit
1	6.288-016.0	Gear oil 1L	1	PC
4	4.553-311.0	Piston complete only for replacement	3	PC
6	6.363-077.0	O-Ring seal 75x3	1	PC
7	5.062-754.3	Thrust guidance	1	PC
8	7.303-047.0	Screw M6x16 -St-R3R (In6Rd)	2	PC
9	7.306-106.0	Cylinder head screw M8x70 -8.8-A2E ISO4	4	PC
11	6.365-432.0	Grooved ring 14x22x5.3	3	PC
12	6.362-376.0	O-Ring seal 24,0 X 1,5	3	PC
13	5.115-465.0	Washer	3	PC
14	5.112-576.3	Bush	3	PC
15	6.365-438.0	Compact seal	3	PC
16	5.115-744.0	Washer	3	PC
17	6.365-340.0	Grooved ring 14X22X5/7	3	PC