



**BR 30/4 C**  
**BR 30/4 C Adv**  
**BR 30/4 C Bp Pack**  
**BR 4.300**  
**Service Manual**





<b>1</b>	<b>Preface</b> .....	<b>5</b>
<b>2</b>	<b>Safety instructions</b> .....	<b>5</b>
	2.1 Hazard levels. ....	5
<b>3</b>	<b>Technical Features</b> .....	<b>5</b>
	3.1 Operation and control .....	5
	3.2 Water System .....	5
	3.3 Vacuuming operations. ....	5
	3.4 Vacuum bar .....	5
	3.5 Electrical system .....	5
	3.6 Cleaning operations .....	6
<b>4</b>	<b>Setup and function</b> .....	<b>7</b>
	4.1 Front view (BR 30/4 C Adv and BR 30/4 C) .....	7
	4.2 Front view (BR 30/4 C Bp Pack) .....	8
	4.3 Rear view (BR 30/4 C Adv and BR 30/4 C / BR 30/4 C Bp Pack). ....	9
	4.4 View from below .....	10
	4.5 Function. ....	11
	4.5.1 Parking/operating position .....	11
	4.5.2 Raising/lowering the vacuum bar .....	11
	4.5.3 Removing the tanks .....	11
	4.5.4 Insert suction nozzle (BR 30/4 C Adv only) .....	13
	4.5.5 Water flow schematic .....	14
	4.5.6 Remove the cover from the cleaning head. ....	15
	4.5.7 Replace the batteries (BR 30/4 C Bp Pack only) .....	15
	4.5.8 LED display on the brush head (BR 30/4 C Bp Pack only) .....	16
	4.5.9 Displays on the charger (BR 30/4 C Bp Pack only) .....	16
	4.5.10 Control board (BR 30/4 C Bp Pack only) .....	17
	4.5.11 Balance weight (BR 30/4 C Bp Pack only) .....	17
<b>5</b>	<b>Basic settings and service procedures</b> .....	<b>18</b>
	5.1 Removing the appliance components .....	18
	5.1.1 Replacing the main switch .....	18
	5.1.2 Replacing the water pump switch. ....	19
	5.1.3 Replacing the brush roller intake .....	20
	5.1.4 Replacing the brush roller .....	21
	5.1.5 Replacing the water distribution bar .....	21
	5.1.6 Replace the vacuum bar. ....	22
	5.1.7 Removing the cleaning head housing .....	22
	5.1.4 Replacing the water pump .....	21
	5.1.9 Voltage measurement on the water pump .....	24
	5.1.10 Replacing the toothed belt .....	24
	5.1.11 Replace the coupling .....	26
	5.1.12 Replacing the suction turbine. ....	26
	5.1.13 Remove the parking position release .....	28
	5.1.14 Cleaning the suction channel, the suction pipe and the suction hose ..	29
	5.1.15 Replace the control board (BR 30/4 C Bp Pack only) .....	30
	5.1.16 Remove the balance weight (BR 30/4 C Bp Pack only) .....	31

5.2	Check the batteries . . . . .	31
5.2.1	Voltage measurement . . . . .	31
5.2.2	Resistance measurement. . . . .	32
<b>6</b>	<b>Troubleshooting . . . . .</b>	<b>33</b>
<b>7</b>	<b>Circuit diagram . . . . .</b>	<b>34</b>
7.1	Circuit diagram 0.089-099.0 - BR 30/4 C (230V/50-60 Hz), BR 4.300 . . . . .	34
7.2	Circuit diagram 0.089-149.0 - BR 30/4 C (120 V/60 Hz) . . . . .	35
7.3	Circuit diagram 0.089-150.0 - BR 30/4 C (100V/50-60 Hz) . . . . .	36
7.4	Circuit diagram 0.089-305.0 - BR 30/4 C Bp Pack . . . . .	37
<b>8</b>	<b>Technical specifications . . . . .</b>	<b>38</b>
8.1	BR 30/4 C - power models . . . . .	38
8.2	BR 30/4 C Bp Pack . . . . .	38
8.3	Exchange times. . . . .	39
8.4	Tightening torques. . . . .	39
8.5	Special tools . . . . .	39
<b>9</b>	<b>Documents . . . . .</b>	<b>40</b>

# 1 Preface

Good service work requires extensive and practice-oriented training as well as well-structured training materials.

Hence we offer regular basic and advanced training programmes covering the entire product range for all service engineers.

In addition to this, we also prepare service manuals for important appliances - these can be initially used as instruction guides and later on as reference guides.

Apart from this, we also regular information about product enhancements and their servicing.

If you should require supplements, have corrections or questions regarding this document, please address these citing the following subject to:  
*international-service@de.kaercher.com*

Subject:	<b>Case 111410</b>
----------	------------------------

The responsible product specialist will take care of your issue.

**Copying and duplication of texts and diagrams as well as third-party access to this information is permitted only with the explicit permission of the company:**

**Alfred Kärcher GmbH & Co. KG**  
P O Box 160  
D -71349 Winnenden  
[www.kaercher.com](http://www.kaercher.com)

# 2 Safety instructions

## 2.1 Hazard levels

### **Note**

*Indicates useful tips and important information about the product.*

# 3 Technical Features

The appliance is used for the wet cleaning of level floors.

A working width of 300 mm and a capacity of 4 l each of the fresh and dirt water reservoirs enable an effective cleaning of smaller surfaces.

The power supply operation allows a high capacity without a restriction of the working time.

## 3.1 Operation and control

- The appliance can be used in a forward motion by pushing it and backwards by pulling it by the handle.

## 3.2 Water System

The fresh water tank must be filled with the correct mixture of water and detergent prior to operation. The detergent solution flows to the brush head via a water pump and is revacuumed by two vacuum bars.

- Content of fresh water tank: 3.7 l
- Content of wastewater reservoir: 3.7 l

## 3.3 Vacuuming operations

The suction turbine (M1) produces a vacuum pressure in the wastewater reservoir, which pulls the wastewater from the vacuum bar to the wastewater reservoir.

If the wastewater reservoir is full, the float closes the suction opening.

The wastewater reservoir can be removed from the appliance for cleaning purposes.

### **Note**

*The suction turbine (M1) does not switch off automatically when the wastewater reservoir is full. Only when you press the main switch, the suction turbine (M1) will shut off.*

For the appliances BR 30/4 C and BR 30/4 C Bp Pack, it is possible to lift the suction bar and perform a wet cleaning only.

The BR 4.300 does not have a suction bar lift.

## 3.4 Vacuum bar

The vacuum bar can be replaced without the use of tools.

## 3.5 Electrical system

The switches for the operation of the appliance are located in the handle and on top of the housing.

- The main switch (S1) for brushing and vacuuming operations are located on top of the housing.
- The switch (S2) for the operation of the water pump (M3) is located in the handle.

### **Mains models**

- 230V / 50/60Hz / 16A.
- 120V / 60Hz / 15A
- 100V / 50/60Hz / 7A

### **BR 30/4 C Bp Pack**

- Two batteries at 25.2 V / 3.3 Ah each

### **3.6 Cleaning operations**

The brush contact pressure cannot be adjusted.  
The brush roller has a diameter of 60 mm. It rotates at 1,450 rpm for the mains model and at 1,270 for the battery model.

#### **BR 30/4 C Adv**

To vacuum in corners, a vacuuming nozzle can be attached to the vacuum pipe of this model.

## 4 Setup and function

### 4.1 Front view (BR 30/4 C Adv and BR 30/4 C)



- 1 Handle
- 2 Cable hook
- 3 Main switch for brushing/vacuuming operations
- 4 Fresh water tank lock
- 5 Release, park position
- 6 Vacuum bar lift pedal
- 7 Cleaning head
- 8 Fresh water tank
- 9 Fresh water level display
- 10 Release of fresh water reservoir
- 11 Dirt water reservoir
- 12 Release, wastewater reservoir
- 13 Carrying handle

14 Water pump switch

## 4.2 Front view (BR 30/4 C Bp Pack)



- 1 Handle
- 2 Main switch for brushing/vacuuming operations
- 3 Fresh water tank lock
- 4 Release, park position
- 5 Vacuum bar lift pedal
- 6 Cleaning head
- 7 Batteries, 2 x 25.2 VDC
- 8 Fresh water tank
- 9 Fresh water level display
- 10 Release of fresh water reservoir
- 11 Dirt water reservoir
- 12 Release, wastewater reservoir
- 13 Carrying handle

- 14 Water pump switch
- 15 Charging station 1
- 16 Charging station 3
- 17 Charger
- 18 Mains cable
- 19 Battery at charging station 4
- 20 Charging station 2
- 21 Battery charge indicator



### 4.3 Rear view (BR 30/4 C Adv and BR 30/4 C / BR 30/4 C Bp Pack)



- 1 Handle
- 2 Cable hook
- 3 Cable hook, rotating
- 4 Vacuum nozzle intake
- 5 Exhaust air cover
- 6 Suction hose
- 7 Release, park position
- 8 Suction tube connection
- 9 Suction pipe
- 10 Bellow
- 11 Vacuum bar holder (BR 30/4 C Adv only)
- 12 Suction nozzle (BR 30/4 C Adv only)
- 13 Vacuum bar (BR 30/4 C Adv only)
- 14 Suction tube handle (BR 30/4 C Adv only)

#### 4.4 View from below



- 1 Park roller
- 2 Space roller
- 3 Rear vacuum bar
- 4 Brush roller
- 5 Front vacuum bar
- 6 Space roller

The spacer rollers prevent the cleaning head from scraping on the floor when the brush is worn.

## 4.5 Function

### 4.5.1 Parking/operating position



→ To operate, the release of the parking position must be pressed (small arrow) and the appliance has to be swivelled back simultaneously. The parking roller submerges into the cleaning head and the brush roller touches the floor.

### 4.5.2 Raising/lowering the vacuum bar



- 1 Pedal position, vacuum bar raised
- 2 Vacuum bar lift pedal
- 3 Pedal position, vacuum bar lowered

The vacuum bars can be raised or lowered using the pedal for the vacuum bar lift.

### Note

Turn the appliance off before you activate the suction bar lift. Otherwise, the brush drive can be triggered. The BR 4.300 does not have a suction bar lift.

### 4.5.3 Removing the tanks



- 1 Dirt water reservoir
- 2 Fresh water tank
- 3 Wastewater inlet opening with seal
- 4 Suction pipe
- 5 Funnel for fresh water inlet
- 6 Suction air channel
- 7 Suction air stub with seal

→ The fresh water reservoir and the wastewater reservoir can be removed to fill, empty and clean the appliance.

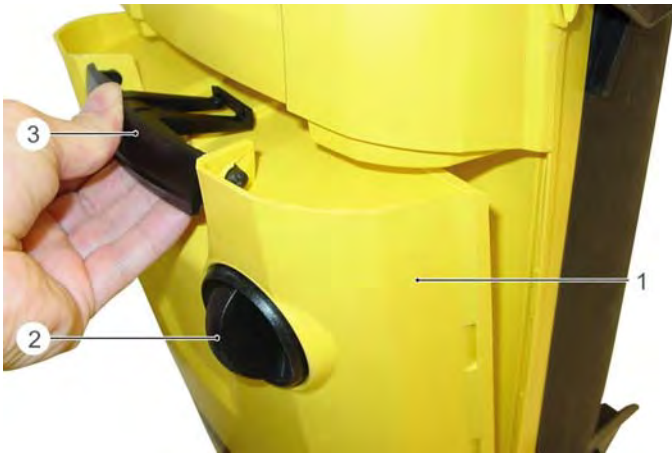

- 1 Fresh water tank
- 2 Fresh water tank lock
- 3 Release of fresh water reservoir

- ➔ Pull on the release and remove the fresh water reservoir from the appliance toward the front.
- ➔ To fill the fresh water tank, open the latch and fill the fresh water tank with water and detergent.

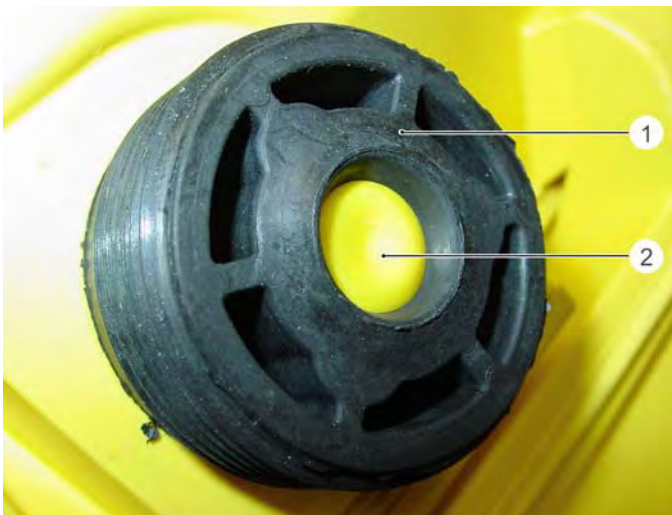

- 1 Water outlet valve
- 2 Tappet

- ➔ The water outlet valve is located at the bottom of the fresh water reservoir.

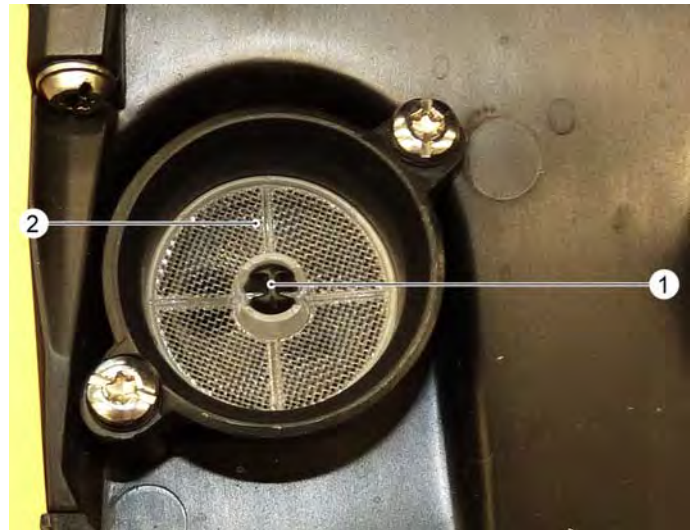

- 1 Valve pin
- 2 Sieve

- ➔ When inserting it into the appliance, the valve pin pushes the tappet into the water outlet valve and the water can flow to the water pump (M2).
- ➔ The contaminated sieve can be removed for cleaning.



- 1 Spring element

- The spring element pushes the wastewater reservoir down. This will prevent damage to the seal rings during the installation of the wastewater reservoir.

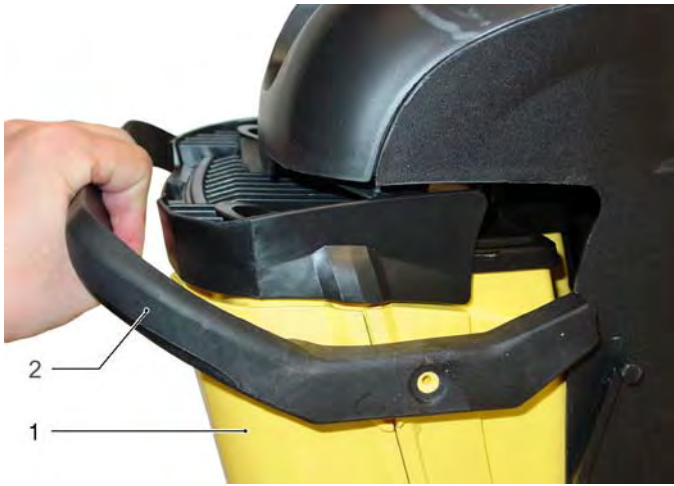

- 1 Dirt water reservoir
- 2 Release, wastewater reservoir

➔ Push the release for the wastewater reservoir down and remove the wastewater reservoir from the appliance toward the front.



- 1 Wastewater inlet opening
- 2 Water separator
- 3 Cover dirt water reservoir
- 4 Seal
- 5 Floater seal
- 6 Locking flap
- 7 Float

➔ The floater is located in the lid. This floater closes up the air suction opening and suctioning is no longer possible.

➔ The wastewater reservoir needs to be emptied.



- 1 Dirt water reservoir
- 2 Cover dirt water reservoir
- 3 Air suction opening
- 4 Wastewater inlet opening
- 5 Lock, lid

➔ The lid of the wastewater reservoir houses the air suction opening and the wastewater inlet opening.

➔ In order to remove the lid, open the lock and pull the lid off the wastewater reservoir upwards.

#### 4.5.4 Insert suction nozzle (BR 30/4 C Adv only)

With model BR 30/4 C Adv, a suction nozzle can be attached to vacuum in corners.

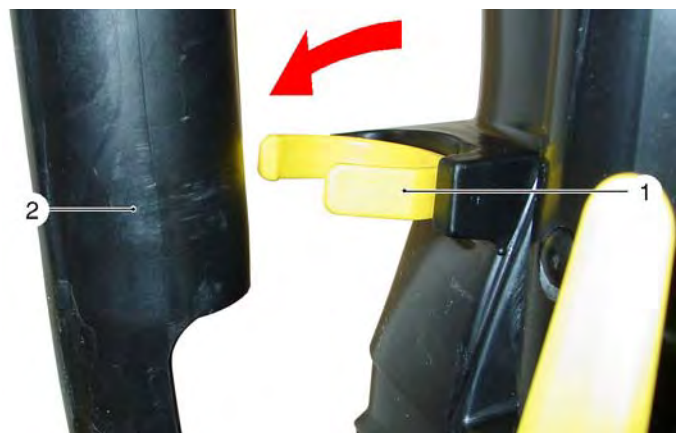

- 1 Suction pipe holder
- 2 Suction pipe

➔ Remove the suction pipe from the suction pipe holder.

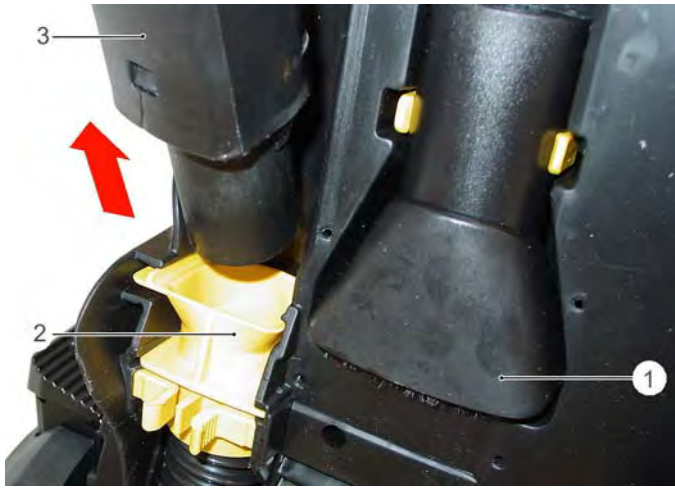

- 1 Suction nozzle
- 2 Suction tube connection
- 3 Suction pipe

➔ Pull the suction pipe out of the suction pipe connection toward the top.



- 1 Suction pipe
- 2 Suction nozzle

➔ Attach the suction nozzle to the suction pipe.

#### 4.5.5 Water flow schematic

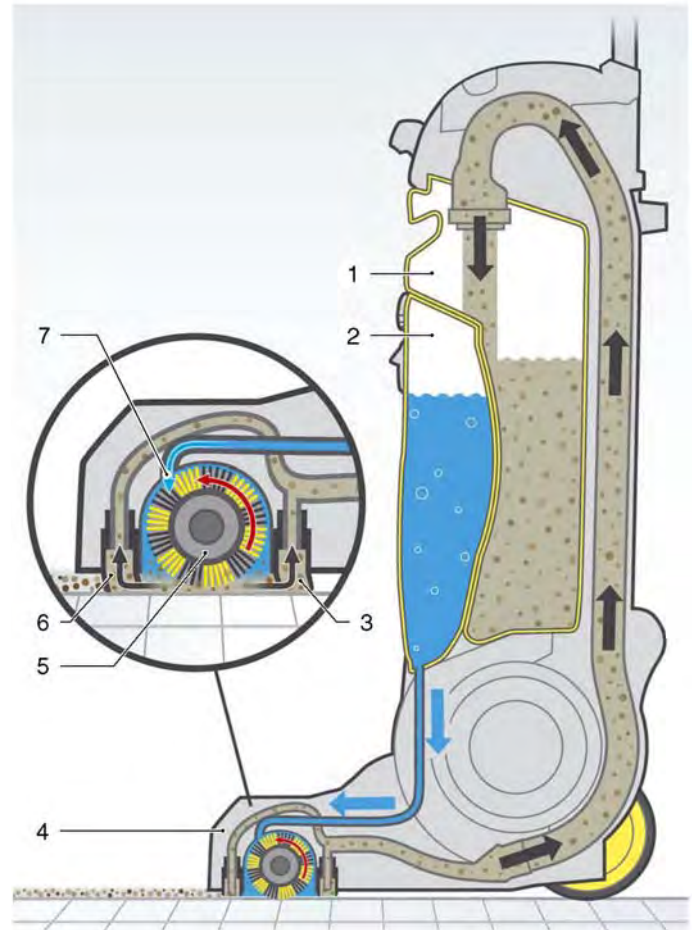

- 1 Dirt water reservoir
- 2 Fresh water tank
- 3 Rear vacuum bar
- 4 Cleaning head
- 5 Brush roller
- 6 Front vacuum bar
- 7 Water distribution bar

#### 4.5.6 Remove the cover from the cleaning head



- 1 Cover of cleaning head
- 2 Vacuum bar lift pedal

→ Remove the cover from the cleaning head toward the top.  
The cover has several hooks that lock into the cleaning head.

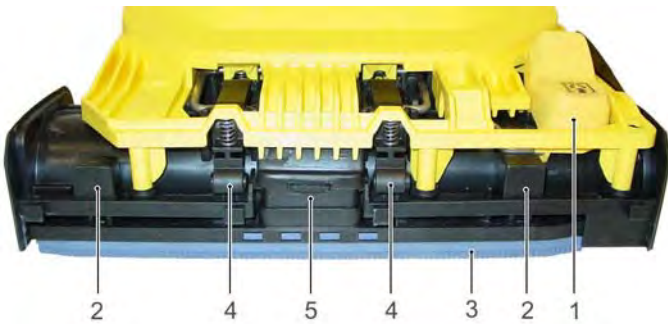

- 1 Vacuum bar lift pedal
- 2 Vacuum bar guide
- 3 Vacuum bar
- 4 Vacuum bar holder
- 5 Suction channel

#### 4.5.7 Replace the batteries (BR 30/4 C Bp Pack only)



- Press the release and pull the depleted battery out of the battery compartment.
- Insert the charged batteries into the battery compartment and push in until they lock into place.

#### 4.5.8 LED display on the brush head (BR 30/4 C Bp Pack only)



- 1 LED operating status display, left battery
- 2 Battery storage
- 3 Battery compartment
- 4 Battery
- 5 LED operating status display, right battery

There are two batteries in the appliance and respectively 2 LED operating status displays. Both can show the colours green, orange and red.

- LED green:  $U = >22.00 \text{ V}$
- LED orange:  $U = >20.00 \text{ V}$
- LED red:  $U = <20.00 \text{ V}$

Both battery voltages are measured after switching on the appliance. The depleted batteries are added and the LED assigned to is will illuminate green when the batteries are fully charged.

The second battery pack is not added until the first one has been discharged and switched off. If the second battery pack is not charged or if the appliance is operated by battery power only, the respective LED will light up red immediately after you turn it on.

As soon as the active batteries do not reach the defined voltage level, the LED will switch to orange. If the batteries have been depleted all the way down to the deep discharge level, it will be switched off. The respective LED will now illuminate in red and the second battery pack will be switched on/added. Its charging status will be displayed via the LED assigned to it according to its voltage level.

After the second battery pack has been depleted, both LEDs will light up red; the appliance will automatically switch off after 30 seconds.

#### 4.5.9 Displays on the charger (BR 30/4 C Bp Pack only)

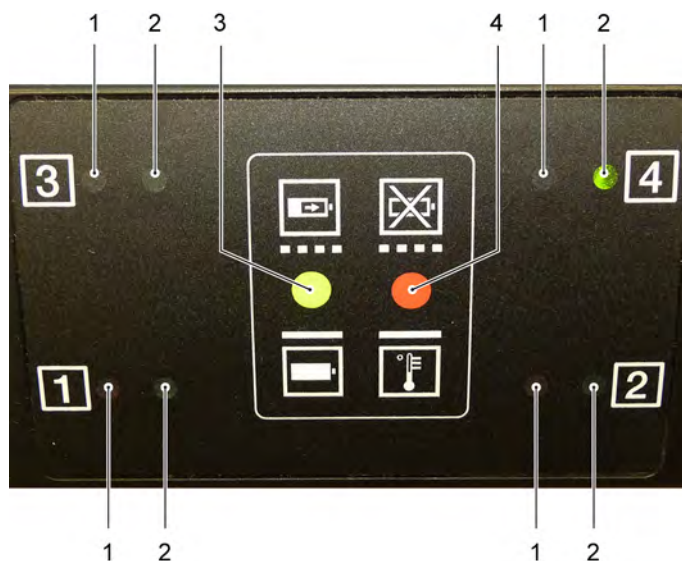

- 1 Red LED charge status display
- 2 Green LED charge status display
- 3 Illumination examples for green LED charge status display
- 4 Illumination examples for red LED charge status display

Every charging station (1-4) has two LED charge status display. A red one and a green one. Depending on the charge status of the batteries, the LEDs will remain illuminated continuously or they will blink.

- Blinks green: Battery is being charged.
- Continuously illuminated green: Battery is fully charged.
- Blinks red: Batteries defective.
- Continuously illuminated red: The batteries are too hot or too cold.

#### Note

*The charger charges the batteries between 0° and 45 °C. If the batteries are inserted into the charger while they are still warm, the red LED will be illuminated. As soon as the batteries have cooled down, the charger will begin charging and the LED will blink green.*



#### 4.5.10 Control board (BR 30/4 C Bp Pack only)

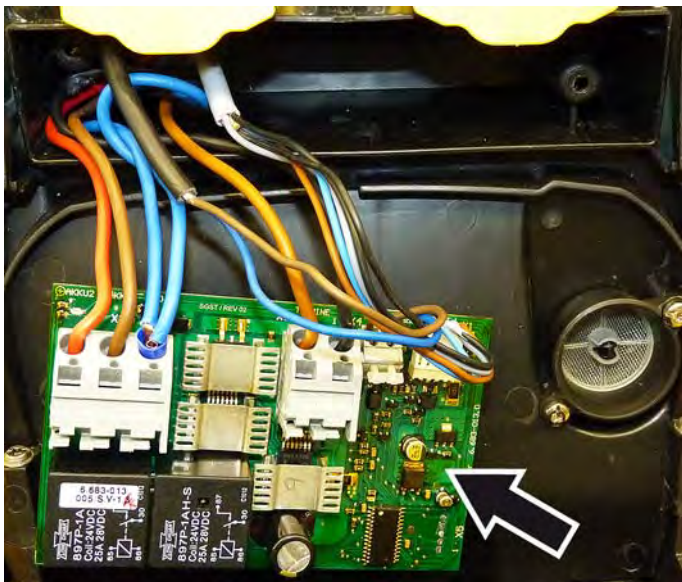

The printed circuit board allows the safe and reliable operation of the battery-powered BR 30/4 via voltage and current measurement.

#### Battery test

There are two different switch-on criteria.

A After every switch-on, both batteries are checked.

The depleted battery is always activated, unless its idle voltage is at least 20.5 Volts. A completely discharged battery is indicated by a red LED immediately and continuously.

If both batteries are below this minimum threshold, the appliance cannot be started.

B During the discharge, the active batteries are measured permanently and switched off accordingly to prevent a depth discharge.

#### Over current switchoff

After switching on the BR 30/4, the electric motor will start via a startup ramp. This will last approx. 3.8 seconds. This way, startup currents that are too high are prevented. With currents  $>45$  A, the motor will be switched off. The switch-off is displayed via the two LED operating status displays. The blink orange. If the appliance is not shut off, the display will remain the same until the batteries have been discharged to 20 Volts. In this case, the display changes to red continuous light. After 30 seconds, the control will shut off automatically.

#### Relay test

When switching on, switching off, or switching from one battery to another, the printed circuit board is checked for sticky relays. If a relay sticks, the appliance cannot be started up. The printed circuit board will give out an error message, both LED operating status displays blink simultaneously with the colours red and orange. The blinking of the LED operating status displays can only be terminated by removing the batteries.

Exception:

A sticky relay during switch on. Here, the display will only show up while the ON switch is pressed.

By checking the relays, the switch must be pressed for 300 ms when turning the appliance on in order to be able to start operating it. A short tapping will not suffice.

#### 4.5.11 Balance weight (BR 30/4 C Bp Pack only)



- 1 Balance weight, brass disc
- 2 Wheel, right

The brass disc is installed into the right wheel (viewed from behind) as a balance weight.

This balance weight is necessary to prevent the appliance from tipping forward due to the heavy batteries. It also prevents the brush roller from being pressed onto the ground in the parking position.

## 5 Basic settings and service procedures

### 5.1 Removing the appliance components

#### 5.1.1 Replacing the main switch



1 Main switch for brushing/vacuuming operations



1 Main switch for brushing/vacuuming operations  
2 De-interference capacitor

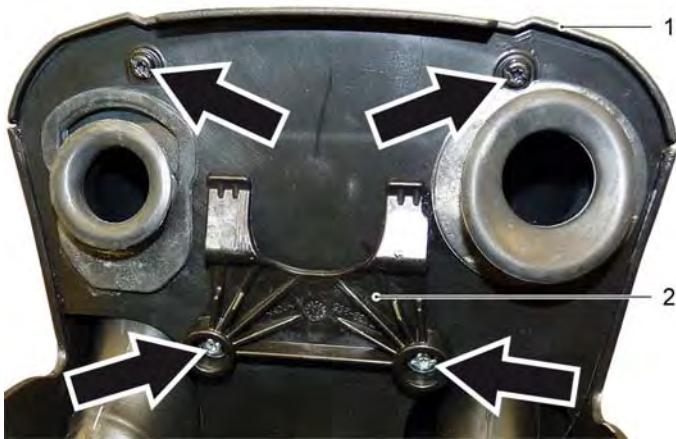

1 Housing top  
2 Spring element

- Remove the wastewater reservoir (see chapter "Removing the tanks").
- Loosen the fastening screws (arrows).
- Slide the casing top toward the top.

- Remove the cable plug connections from the main switch.
- Push the main switch out of the top of the housing.
- Install the new main switch in reverse order.

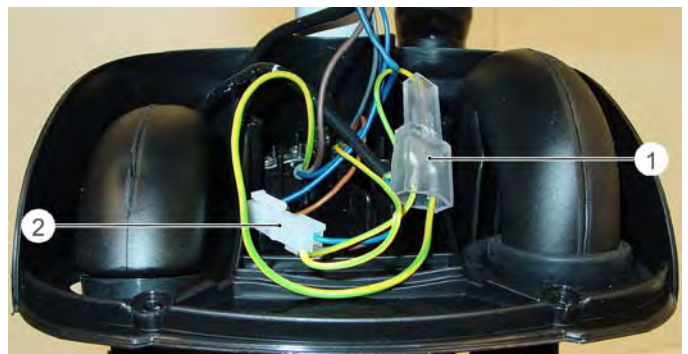

1 Connector, protective conductor cable  
2 Connector, pump

#### Main switch / check switch

- Connect a resistance gauge between the connection plug 1 and 1a or 2 and 2a.

#### Target value:

Main switch turned off = >1 MOhm

Main switch turned on = <2 Ohm

#### Note

For the BR 30/4 Bp, the switch must be pressed for >300 msec for the appliance to be switched on.

## BR 30/4 C Bp Pack



1 Connector, pump

### 5.1.2 Replacing the water pump switch



- 1 Fastening screws (3x), housing cover
- 2 Covering lid
- 3 Water pump switch

→ Unscrew locking screws.

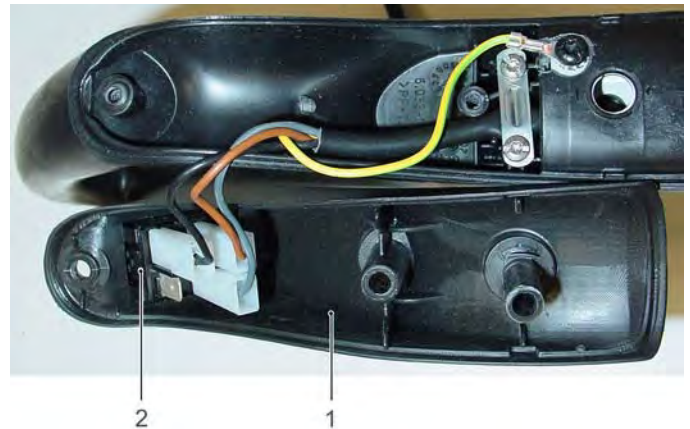

- 1 Covering lid
- 2 Water pump switch

- Remove the housing cover.
- Remove the cable plug connections from the water pump switch.
- Press the water pump switch out of the housing cover from the inside out.
- Install the new water pump switch in reverse order.

#### Check the water pump switch

- Connect a resistance gauge between the connection plug 1 and 1a or 2 and 2a.

#### Target value:

Water pump switch turned off = >1 MOhm

Water pump switch turned on = <2 MOhm

### 5.1.3 Replacing the brush roller intake



- 1 Fastening screws (3x), cover
- 2 Cover

- ➔ Unscrew locking screws.
- ➔ Remove cover.

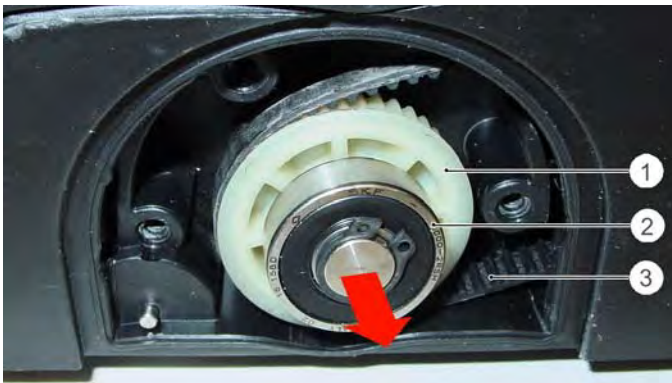

- 1 Toothed belt disc
- 2 Outer ball bearing
- 3 Gear belt

- ➔ Remove the drive unit from the cleaning head.

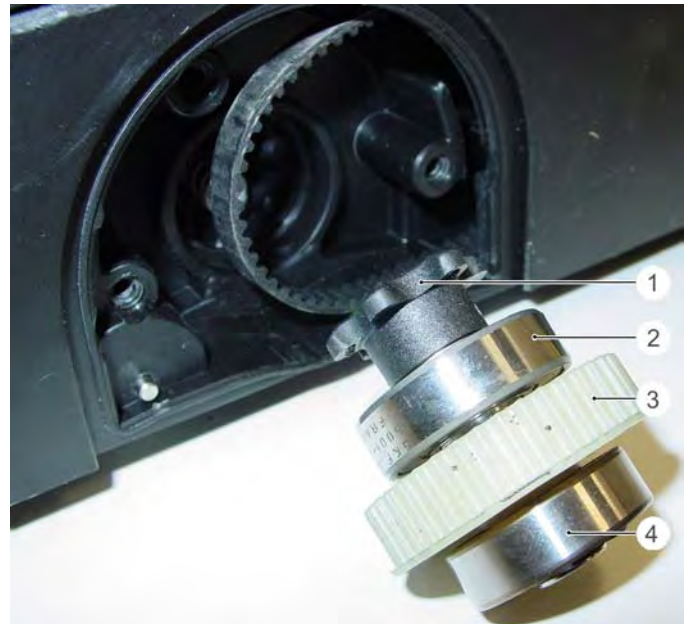

- 1 Towing, brush roller
- 2 Inner ball bearing
- 3 Toothed belt disc
- 4 Outer ball bearing

- ➔ Install the new drive unit in reverse order.

### 5.1.4 Replacing the brush roller

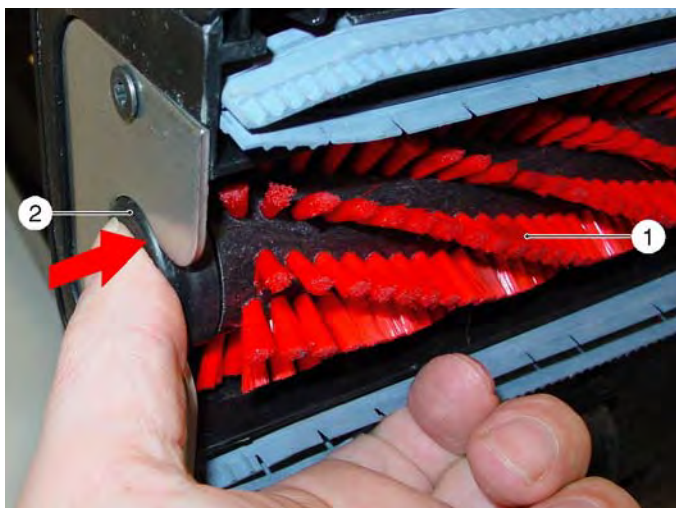

- 1 Brush roller
- 2 Unlocking button for the changeable brush

→ Press the unlocking button of the brush roller.



→ Swivel the brush roller out of the cleaning head and remove.



- 1 Towing, brush roller

→ Install the new brush roller in reverse order.

→ When inserting the brush roller, make sure that the towing is properly placed in the brush roller.

### 5.1.5 Replacing the water distribution bar



- 1 Water distribution bar

→ Remove the brush roller (see chapter "Removing the brush roller").



- 1 Water distribution bar
- 2 Rubber tab, water distribution bar
- 3 Water outlet
- 4 Cover, water distribution bar

→ Pull the water distribution bar out of the cleaning head by the rubber tab.

→ Install the new water distribution bar in reverse order press firmly onto the water outlet.

The water distribution bar has a cover on both sides, which can be opened. If necessary, the water distribution bar can be rinsed with water.

### 5.1.6 Replace the vacuum bar.

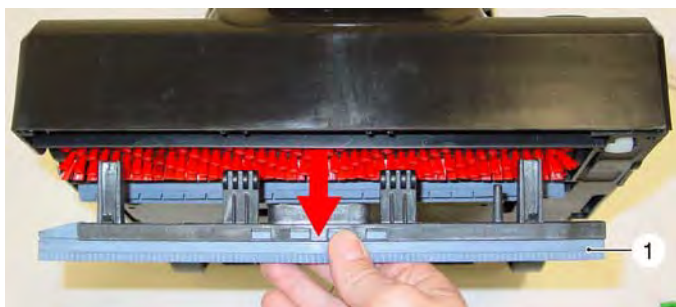

1 Vacuum bar

The vacuum bars can be replaced without the use of tools.

- ➔ Move the pedal for the vacuum bar lift to the pedal position "vacuum bar lowered" (see Chapter "Raising/lowering the vacuum bar").
- ➔ Pull the vacuum bar out of the vacuum bar support.

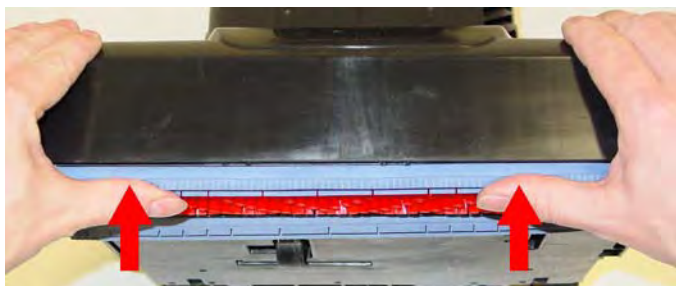

- ➔ Insert the new vacuum bar from the bottom into the vacuum bar support from the bottom and press upward, until the vacuum bar is locked with an audible "click".

#### Note

*The standard suction bar is not suitable for vacuuming oil-soiled floors. In this case, you must use oiltight suction lips.*

### 5.1.7 Removing the cleaning head housing

- ➔ Remove the front vacuum bar (see chapter "Replacing the vacuum bar").

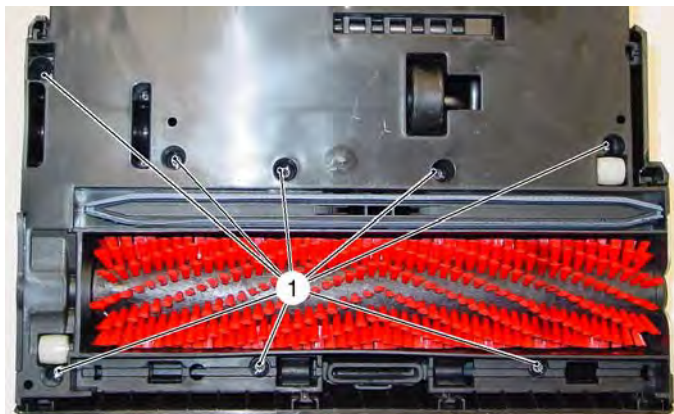

1 Fastening screws (8x), cleaning head housing

- ➔ Unscrew locking screws.



1 Fastening screws (2x), wheel mount

- ➔ Unscrew the cap and fastening screw of the wheel mount and remove the wheel.



1 Fastening screws (2x) per side, cleaning head housing  
2 Mount, release park position  
3 Intake, fastening screw, wheel mount

- Loosen the fastening screws on both sides.
- Remove the release of the parking position (see chapter "Removing the parking position release").
- Removing the housing from the cleaning head.

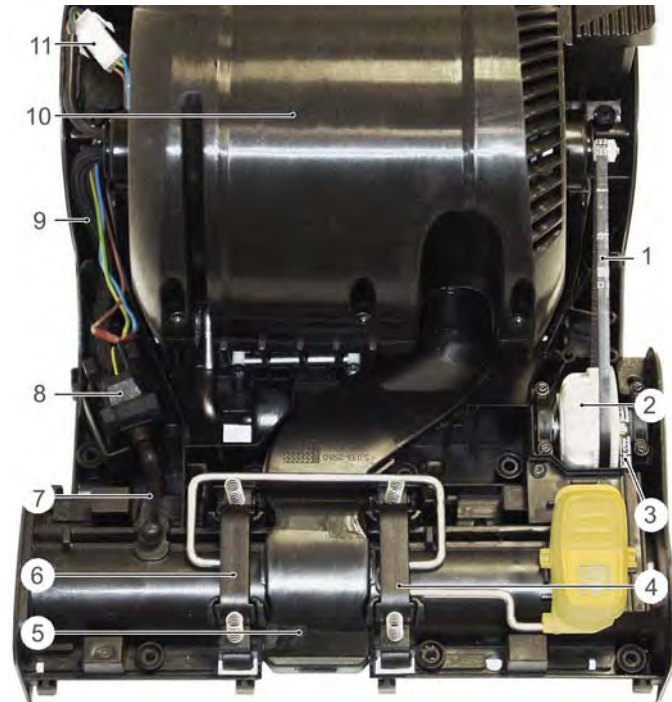

- 1 Toothed belt, from suction turbine
- 2 coupling
- 3 Toothed belt to the brush roller drive
- 4 Right vacuum bar support
- 5 Suction channel
- 6 Left vacuum bar support
- 7 Shaped hose, water distribution bar connection
- 8 Water pump (M2)
- 9 Water hose to the water pump
- 10 Suction turbine housing
- 11 Connector, connecting cable to water pump

### 5.1.8 Replacing the water pump

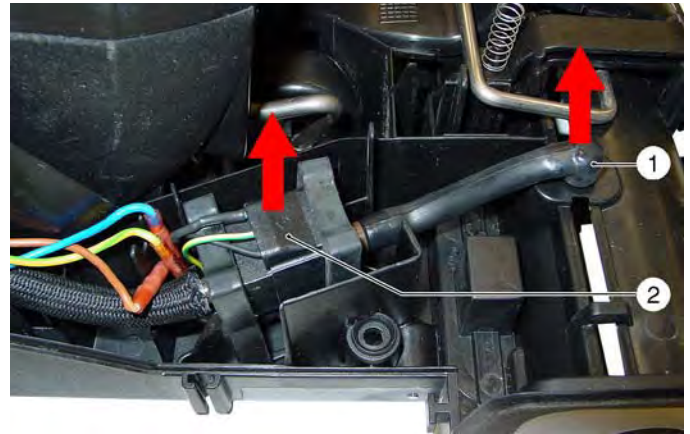

- 1 Shaped hose, water distribution bar connection
- 2 Water pump (M2)

- Remove the cleaning head housing (see chapter "Removing the cleaning head housing").
- Pull the shaped hose off the connection of the water distribution bar.
- Pull the water pump out of the water pump holder toward the top.

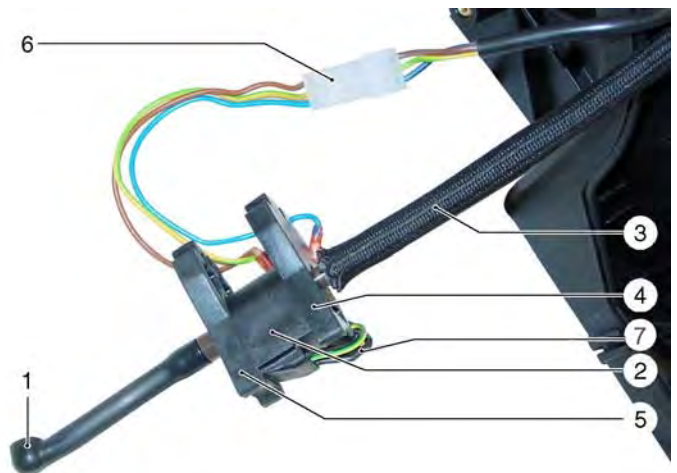

- 1 Shaped hose, water distribution bar connection
- 2 Water pump (M2)
- 3 Water hose to the water pump
- 4 Pump holder, rubber
- 5 Pump holder, rubber
- 6 Connector, connecting cable to water pump
- 7 Diode, soldered into the cable

The rectifier diode converts AC voltage to pulsating direct voltage. This will result in the water pump feeding the water evenly.

The supply voltage can be read at the Molex plug.

**Target value:**

Water pump switch turned off = 0 V AC

Water pump switch turned on = current voltage

**BR 30/4 C Bp Pack**

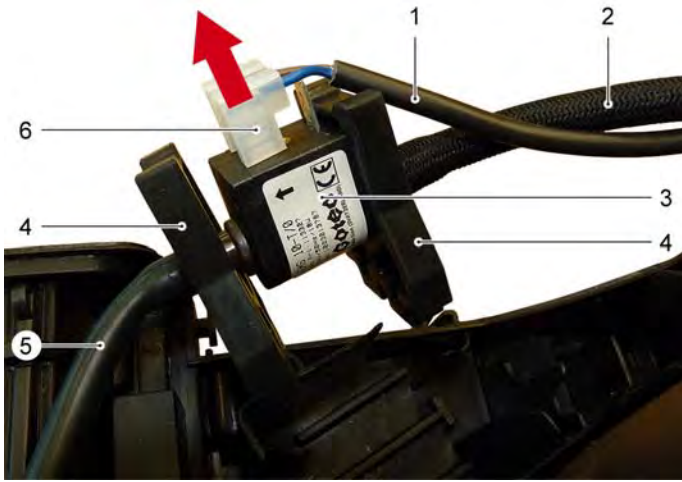

- 1 Connecting cable
- 2 Water hose to the water pump
- 3 Water pump (M2)
- 4 Pump holder, rubber
- 5 Shaped hose, water distribution bar connection
- 6 Connector, connecting cable to water pump

- Pull the shaped hose off the water pump.
- Pull the hose off the water pump.
- Remove the pump holder from the water pump.
- Disconnect the connectors
- Install the new water pump in reverse order.

### 5.1.9 Voltage measurement on the water pump

#### Note

BR 30/4 C only Bp Pack:

The connection voltage of 24 Volts is pulsed; therefore, only about 12 Volts can be measured on the water pump.

This water pump does not have a diode. The water pump is monitored by current. If the current pickup is too high, it is switched off.

### 5.1.10 Replacing the toothed belt

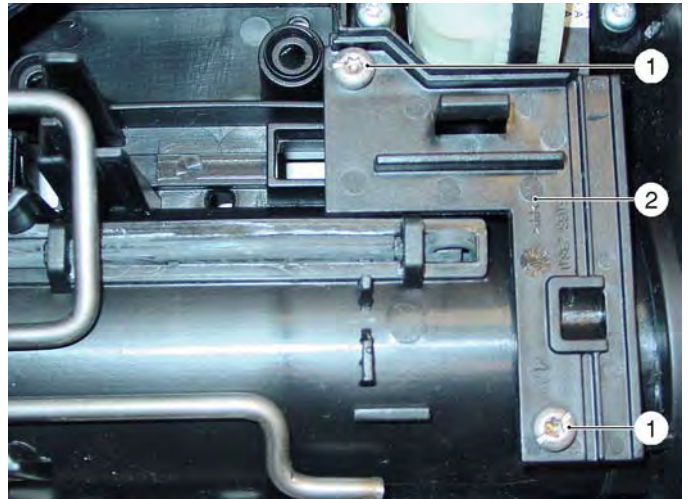

- 1 Fastening screws (2x), cover
- 2 Cover

- Remove the cleaning head casing (see chapter "Removing the cleaning head casing").
- Unscrew locking screws.
- Remove cover.

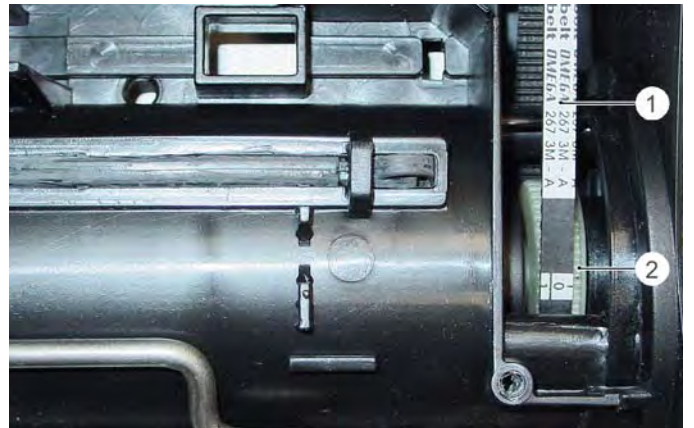

- 1 Toothed belt to the brush roller drive
- 2 Drive unit, brush roller

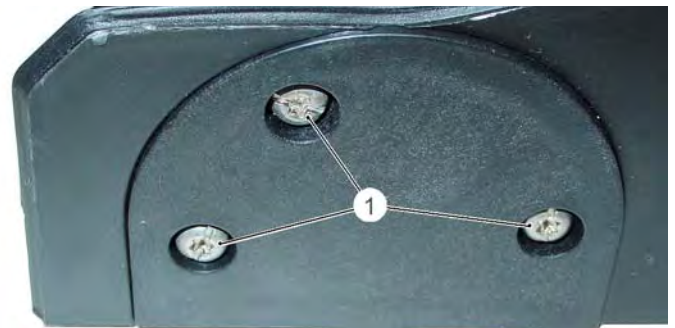

- 1 Fastening screws (3x), cover of drive unit

- Unscrew locking screws.
- Remove cover.



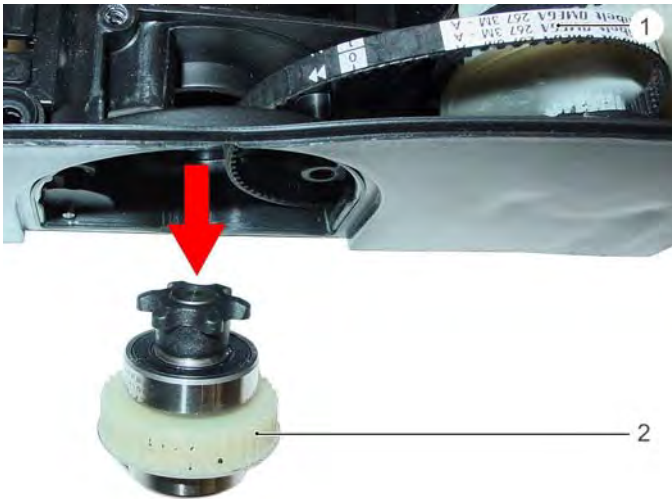

- 1 Toothed belt to the brush roller drive
- 2 Drive unit, brush roller
- ➔ Remove the drive unit from the cleaning head.

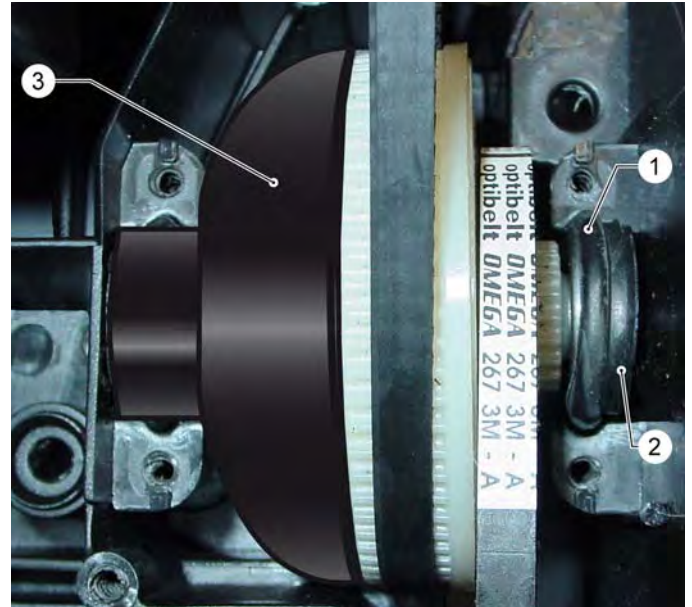

- 1 Rubber ring (2x)
- 2 Bearing (2x)
- 3 Cap

➔ Remove the cap.

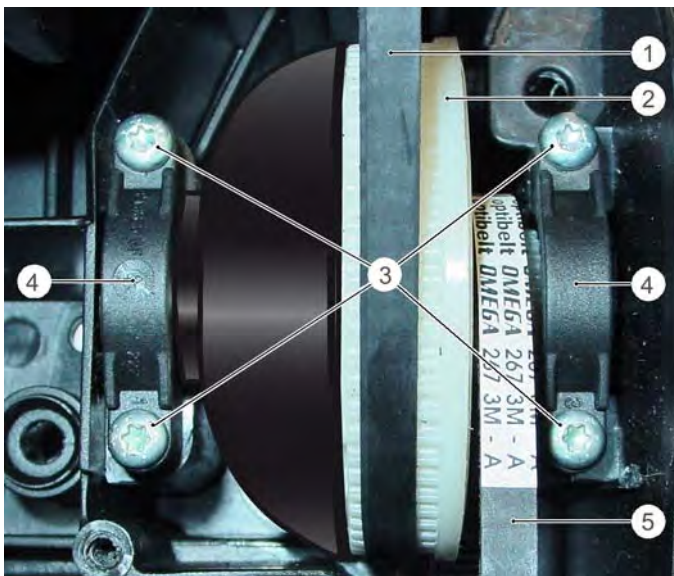

- 1 Toothed belt, from suction turbine
- 2 coupling
- 3 Fastening screws (4x), half bearings
- 4 Half bearings
- 5 Toothed belt to the brush roller drive

- ➔ Unscrew locking screws.
- ➔ Remove the half bearings.



- 1 Toothed belt, from suction turbine
- 2 coupling
- 3 Toothed belt to the brush roller drive

- ➔ Remove the coupling toward the top.
- ➔ Remove both toothed belts.
- ➔ Install the new toothed belts in reverse order.

**Note**

*The coupling is triggered in case of an overload and emits very loud noises. Switch off the appliance briefly and remove the blockage. The coupling will lock in automatically and the appliance can be used once again.*

### 5.1.11 Replace the coupling

- ➔ Remove the cleaning head casing (see chapter "Removing the cleaning head casing").
- ➔ Remove the cover, as described in the chapter "Replacing the toothed belt".
- ➔ Unscrew the fastening screws of the bearing halves, as described in the chapter "Replacing the toothed belt".

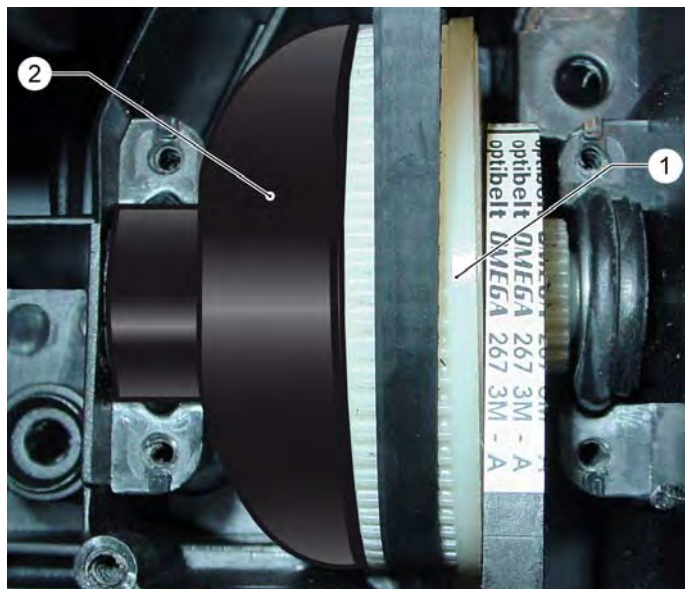

- 1 coupling
- 2 Cap

- ➔ Remove the coupling toward the top.
- ➔ Remove both toothed belts.
- ➔ Remove the cap.
- ➔ Install the new coupling in reverse order.

The cap has the function to prevent the toothed belt of the suction turbine from slipping into the coupling.

#### Note

*The coupling is triggered in case of an overload and emits very loud noises. If the appliance is switched off briefly, the coupling will lock in automatically and the appliance can be used once again.*

*Turn the appliance off before you activate the suction bar lift. Otherwise, the brush drive can be triggered.*

### 5.1.12 Replacing the suction turbine

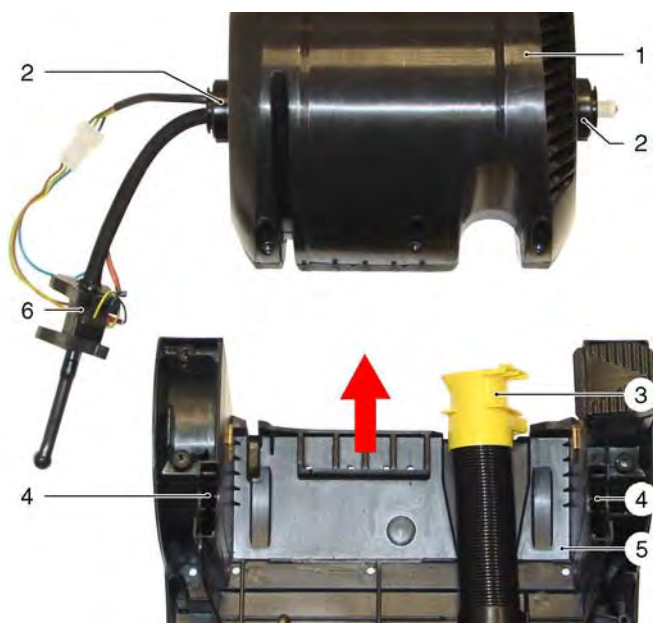

- 1 Suction turbine housing
- 2 Axle
- 3 Suction tube connection
- 4 Bearing for axle
- 5 Cleaning head - bottom part
- 6 Water pump (M2)

- ➔ Remove the cleaning head casing (see chapter "Removing the cleaning head casing").
- ➔ Disconnect the connection of the suction pipe from the suction pipe and remove them from the housing.
- ➔ Removing the suction turbine housing from the bottom part of the cleaning head.

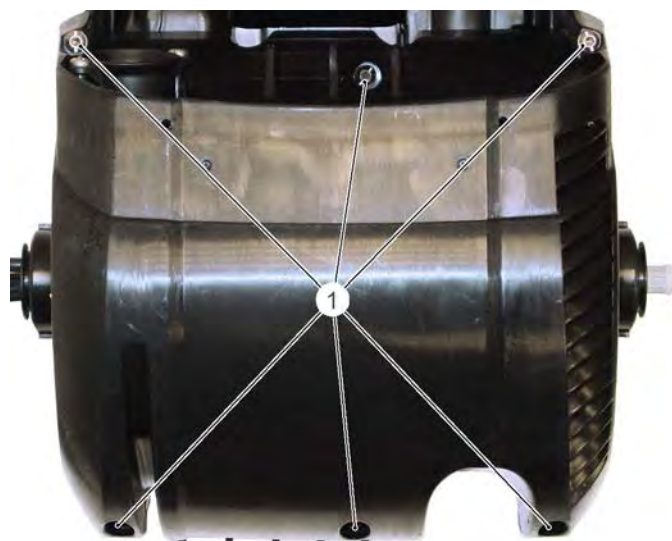

- 1 Fastening screws (6x), half bearings, suction turbine housing

- ➔ Unscrew locking screws.



1 Bearing ring (2x), axle

➔ Remove the bearing ring from both sides.

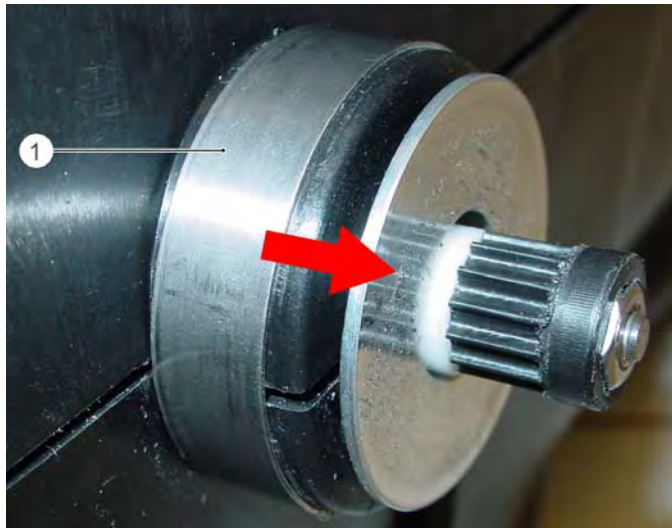

1 Metal clamp ring (2x)

➔ Remove the metal clamp rings from both sides.



1 Bottom half bearing, suction turbine housing  
2 Suction turbine (M1)  
3 Top half bearing, suction turbine housing

➔ Remove the top half bowl of the suction turbine housing.



1 Bottom half bearing, suction turbine housing  
2 Suction turbine (M1)

➔ Remove the suction turbine from the bottom half bowl.

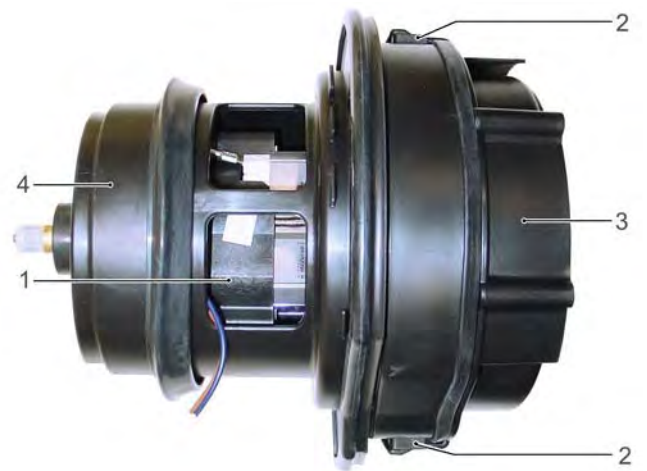

1 Suction turbine (M1)  
2 Lock (2x), housing cover  
3 Covering lid  
4 Bottom housing part

➔ Open locks on both sides of the housing cover and remove the housing cover.

➔ Pull the bottom part of the housing from the suction turbine.

### 5.1.13 Remove the parking position release



- 1 Connection cable suction turbine
- 2 Connector, connecting cable, suction turbine

- ➔ Unplug the connector of connecting cable to the suction turbine.
- ➔ Install the new suction turbine in reverse order.

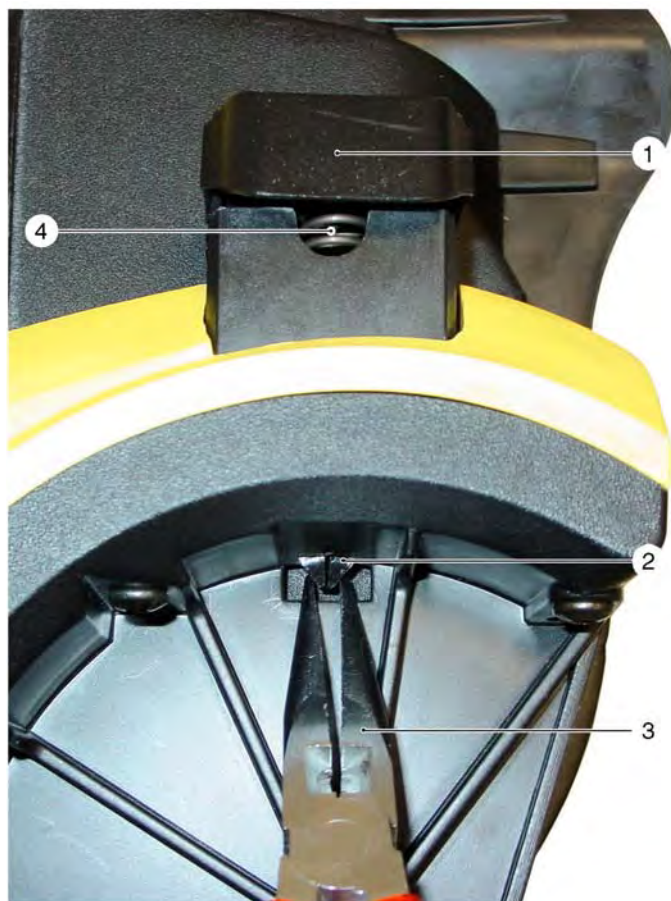

- 1 Release, park position
- 2 Locking tabs
- 3 Pliers
- 4 Pressure spring

- ➔ Remove the wheel (see chapter "Removing the cleaning head").
- ➔ Press the locking tabs together with pliers and, at the same time pull the release out of the housing toward the top.

#### **Caution:**

A pressure spring is located under the release.

- ➔ Install the release in reverse order.

### 5.1.14 Cleaning the suction channel, the suction pipe and the suction hose

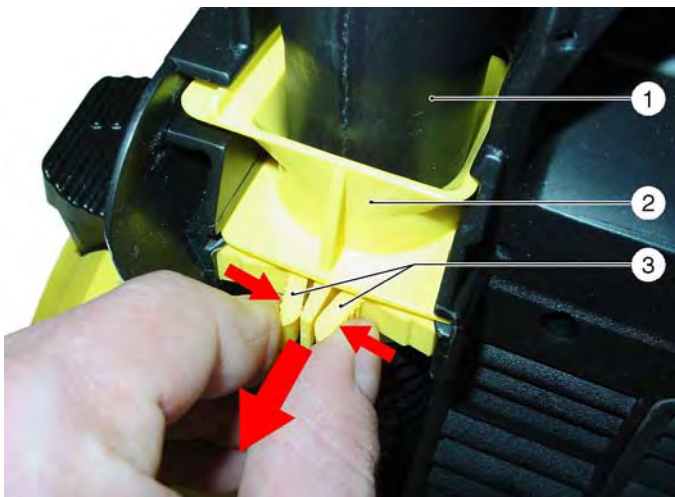

- 1 Suction pipe
- 2 Suction tube connection
- 3 Locks on the suction pipe connection

- ➔ Remove the tanks from the appliance (see chapter "Removing the tanks").
- ➔ Press together the locks on the suction pipe connection and, at the same time pull the connection of the suction pipe and the suction pipe out of the appliance toward the rear.



- 1 Suction pipe
- 2 Suction tube connection

- ➔ The suction pipe and the suction pipe connections are accessible for cleaning.

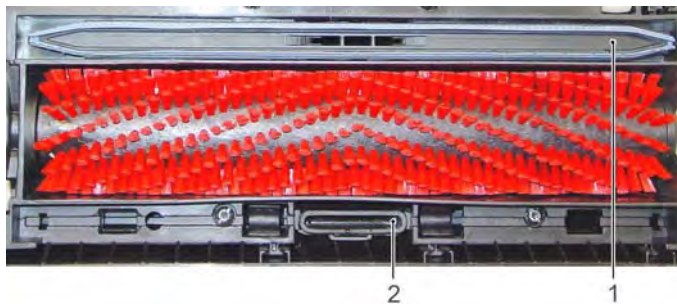

- 1 Vacuum bar (2x)
- 2 Suction channel

- ➔ Remove both vacuum bars from the vacuum bar support (see chapter "Replacing the vacuum bar").
- ➔ The suction channel is accessible for cleaning.
- ➔ Flush the suction hose and the suction channel with water or pull or push the obstruction out with a blunt object (such as a cable tie or a similar object).

### 5.1.15 Replace the control board (BR 30/4 C Bp Pack only)

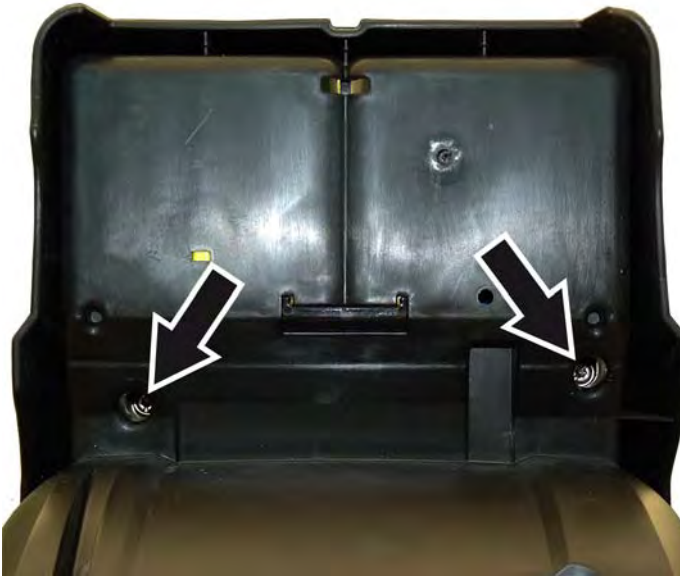

- ➔ Press the park position release and tilt the appliance backwards.
- ➔ Loosen the fastening screws (arrows).



- 1 Circuit board cover  
➔ Remove the board cover.

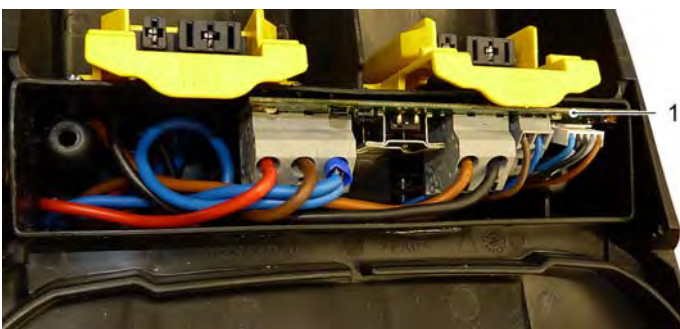

- 1 Control board  
➔ Remove the control board from the printed circuit board chute.

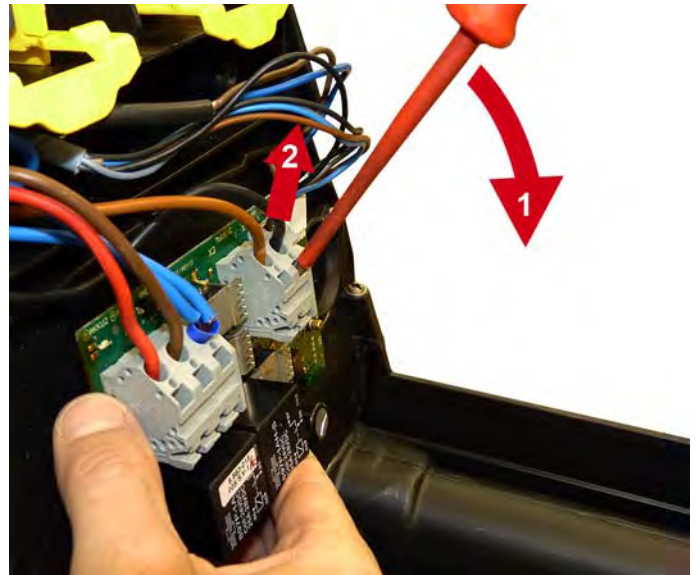

- ➔ Remove all cable connections from the control board.

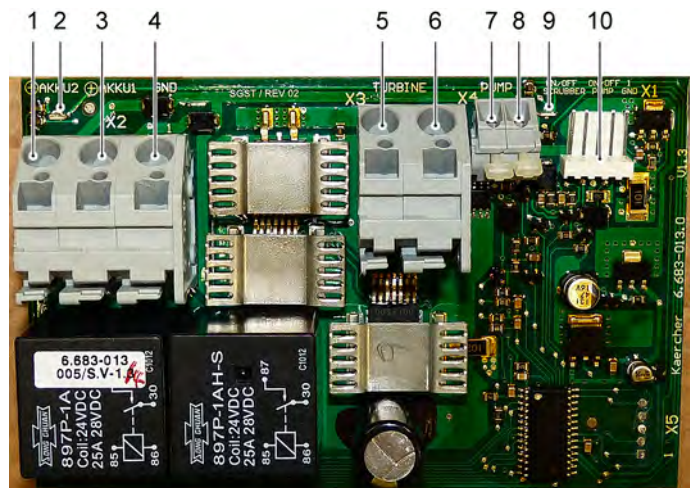

- |    |      |   |
|----|------|---|
| 1  | X2/2 | Terminal strip batteries 1              |
| 2  |      | LED operating status display, batteries |
| 3  | X2/3 | Terminal strip batteries 2              |
| 4  | X2/1 | Terminal strip ground                   |
| 5  | X3/2 | Terminal strip suction turbine          |
| 6  | X3/1 | Terminal strip suction turbine          |
| 7  | X4/2 | Terminal strip water pump               |
| 8  | X4/1 | Terminal strip water pump               |
| 9  |      | LED operating status display, batteries |
| 10 | X1   | Socket plug connection                  |

- ➔ Install the control board in the reverse order.

**Note**

*In order to facilitate the installation of the board cover, it is recommended to remove the battery locks.*

### 5.1.16 Remove the balance weight (BR 30/4 C Bp Pack only)

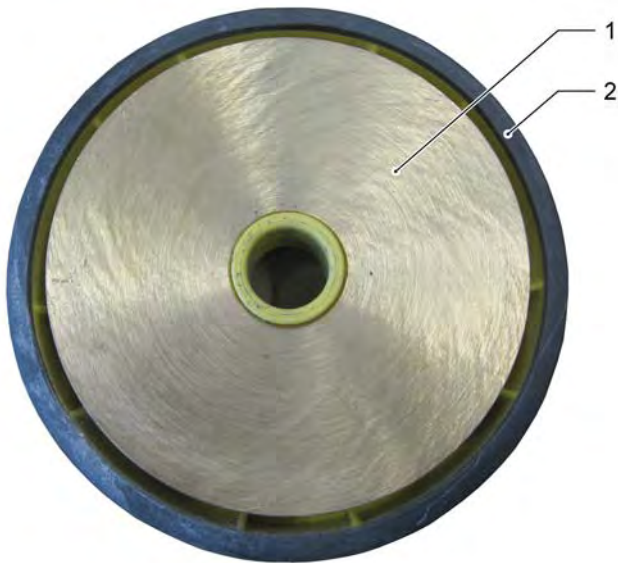

- 1 Balance weight, brass disc
- 2 Wheel

→ Remove the wheel (see chapter "Removing the cleaning head").

→



→ The balance weight can be removed by using two screwdrivers.

→ During the installation, ensure that the balance weight is slid all the way onto the axle.

## 5.2 Check the batteries

### 5.2.1 Voltage measurement

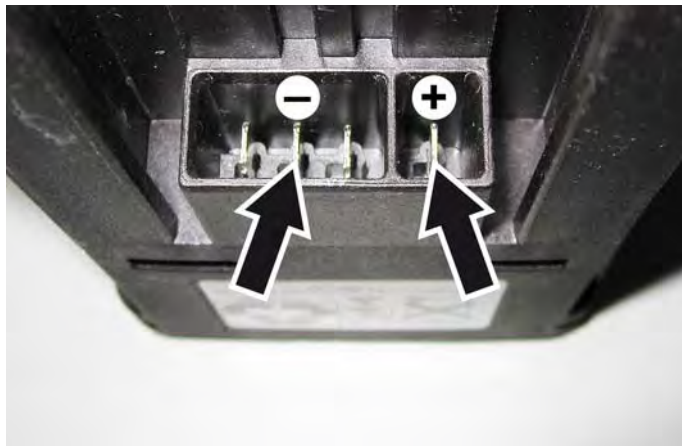

To measure the voltage, the gauge must be connected to the positive and negative plug contacts (see arrows).



#### Target value:

Between 17.5 and 27.5 VDC depending on the charge status. If the voltage is lower than that, the batteries have been deep discharged or they are defective.

### 5.2.2 Resistance measurement

During resistance measurement, 2 values can be determined.

#### Measurement value 1

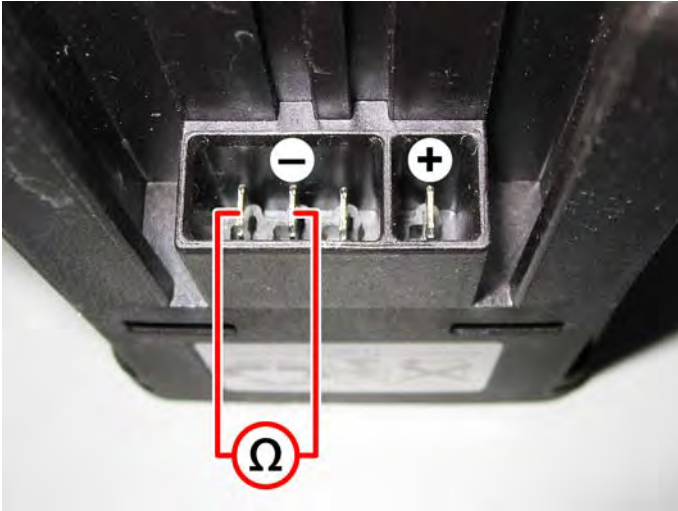

To measure the resistance, the gauge must be connected to plug contacts (as shown in the illustration).

#### Target value:

11 kOhm

If the resistance is significantly higher or lower, the batteries are defective.

#### Measurement value 2

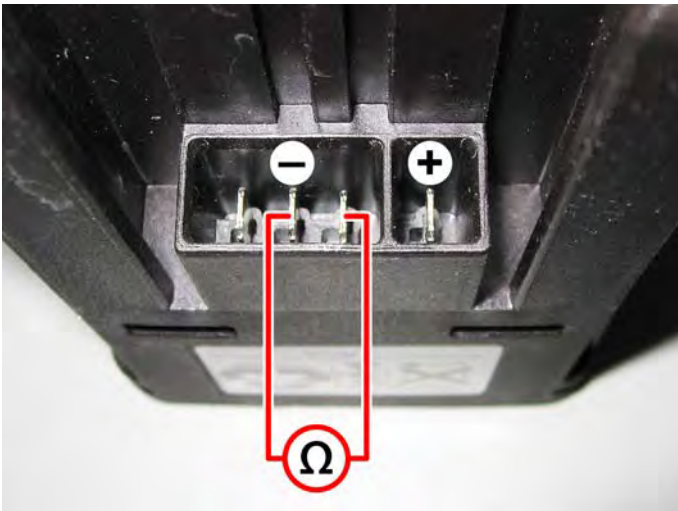

To measure the resistance, the gauge must be connected to plug contacts (as shown in the illustration).

#### Target value:

7.8 kOhm at 20 °C

This value is temperature-dependent.

#### Note

*The batteries can assume a temperature of up to 55 °C during the discharge process.*



## 6 Troubleshooting

Fault	Remedy	
Appliance cannot be started	Check power connection/conduit.	
	Check/replace the main switch	S1
	Check/insert the batteries, charge them as necessary (BR 30/4 C Bp Pack only)	
No or insufficient water supply	Fill up fresh water reservoir.	
	Check/clean the water outlet valves on the fresh water reservoir.	
	Check the water hoses to the cleaning head / remove obstruction / bend location.	
	Check/clean/replace the water distribution bar.	
	Check/replace the water pump.	M2
	Check/replace the water pump switch.	S2
Fresh water reservoir drips when refilled	Check/clean the water outlet valves on the fresh water reservoir.	
Suction is too low	Empty the dirt water reservoir.	
	Check the correct positioning of the wastewater reservoir.	
	Clean/check/replace the seals between wastewater reservoir and cover and check for tightness.	
	Check the seals between the lid of the waste water reservoir and the appliance.	
	Check/lock the correct positioning of the vacuum bar.	
	Check the vacuum bar for wear and tear, replace if necessary.	
	Check the suction pipe connection, whether the suction hose and the suction pipe are properly connected, connect properly if necessary.	
	Check the vacuum bar, suction pipe and suction channel in the cleaning head for obstructions, clear if necessary.	
	Check/replace the suction turbine.	M1
	Check whether the cable behind the tanks has been routed flat and whether the included cover is attached (current model only).	
Insufficient cleaning result	Check brush roller for foreign bodies	
	Check/replace the brush roller.	
	Check/replace the toothed belt.	
Brush roller does not rotate	Check brush roller for foreign bodies	
	Coupling disengaged, check.	
	Check/replace the toothed belt.	
	Check/replace the suction turbine.	M1
	Check brush roller intake.	
Both LEDs blink orange (BR 30/4 Bp)	Overcurrent switch-off of brush motor. Check brush roller for foreign bodies.	M1
The water pump starts up only briefly, overcurrent shutoff of the pump (BR 30/4 Bp)	Check the water pump.	M2
Both LEDs blink red/orange alternately (BR 30/4 Bp)	Relay sticking / check the control board.	A1

## 7 Circuit diagram

### 7.1 Circuit diagram 0.089-099.0 - BR 30/4 C (230V/50-60 Hz), BR 4.300

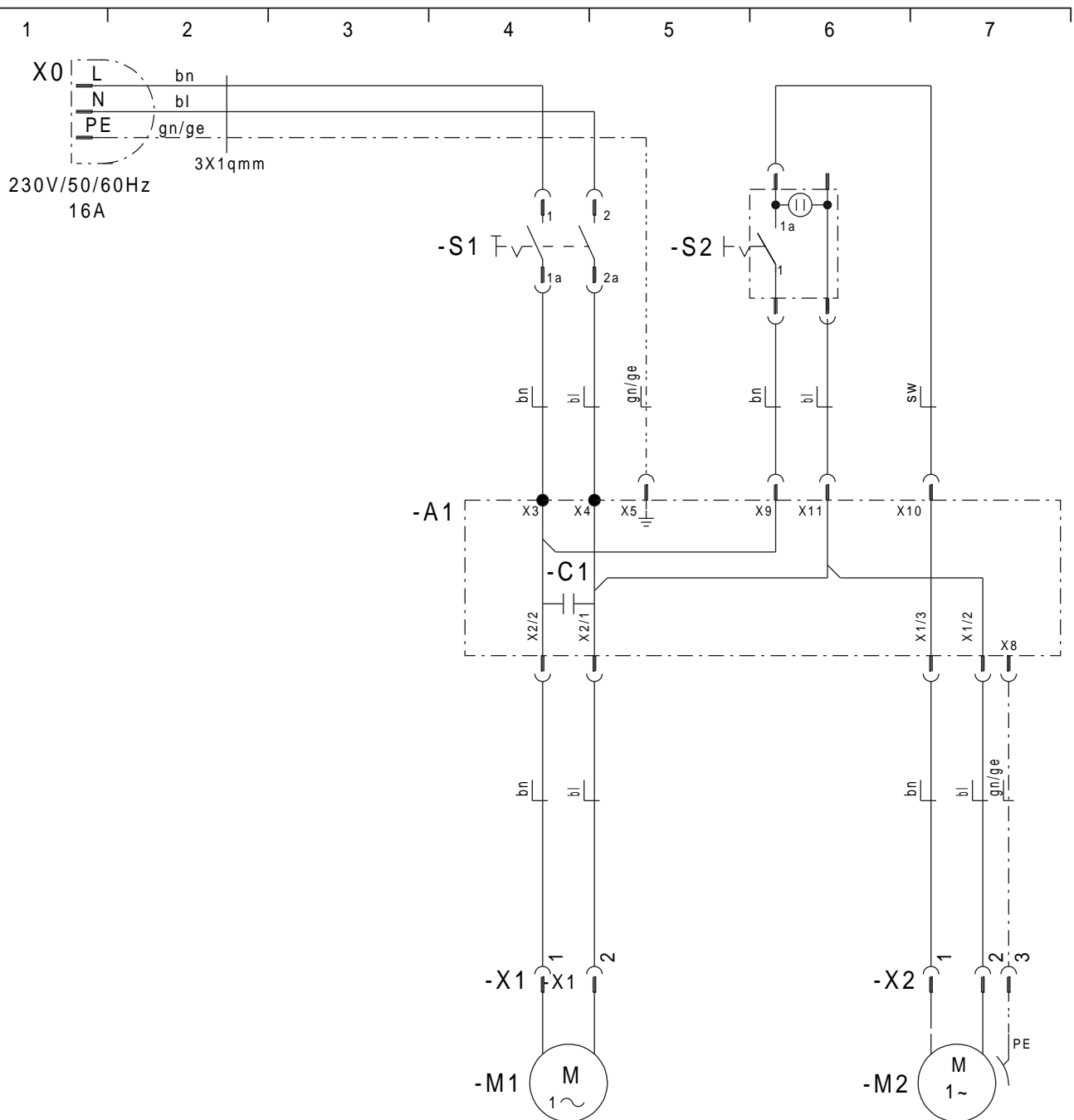

A1	Distribution board
C1	De-interference capacitor, 0,22 $\mu$ F
M1	Brush motor
M2	Water pump
S1	Main switch for brushing/vacuuming operations
S2	Water pump switch
X0	Mains plug
X1	Connector 2 pin
X3	Connector 3 pin

## 7.2 Circuit diagram 0.089-149.0 - BR 30/4 C (120 V/60 Hz)

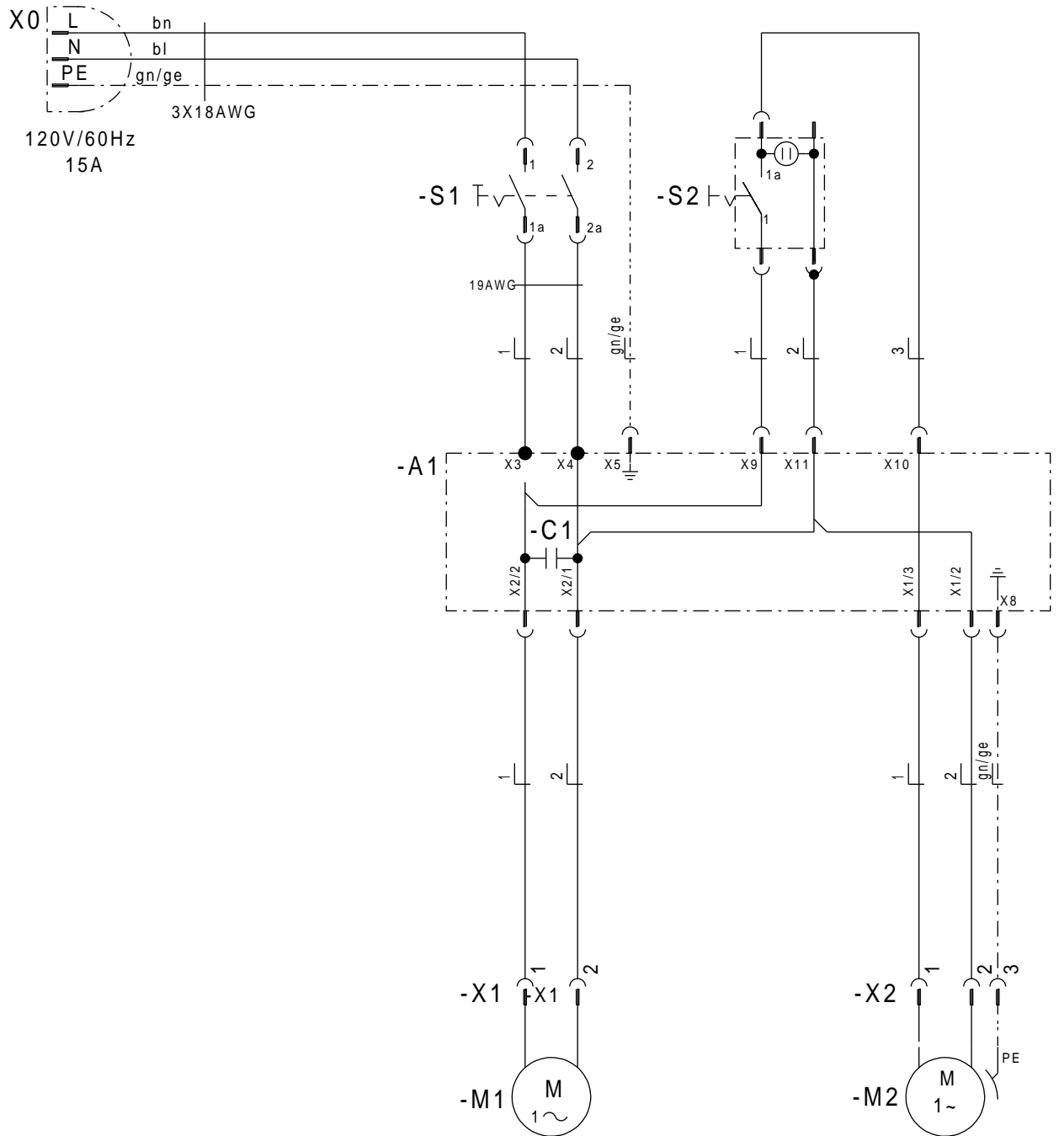

A1	Distribution board
C1	De-interference capacitor, 0,22 $\mu$ F
M1	Brush motor
M2	Water pump
S1	Main switch for brushing/vacuuming operations
S2	Water pump switch
X0	Mains plug

X1	Connector 2 pin
X3	Connector 3 pin

### 7.3 Circuit diagram 0.089-150.0 - BR 30/4 C (100V/50-60 Hz)

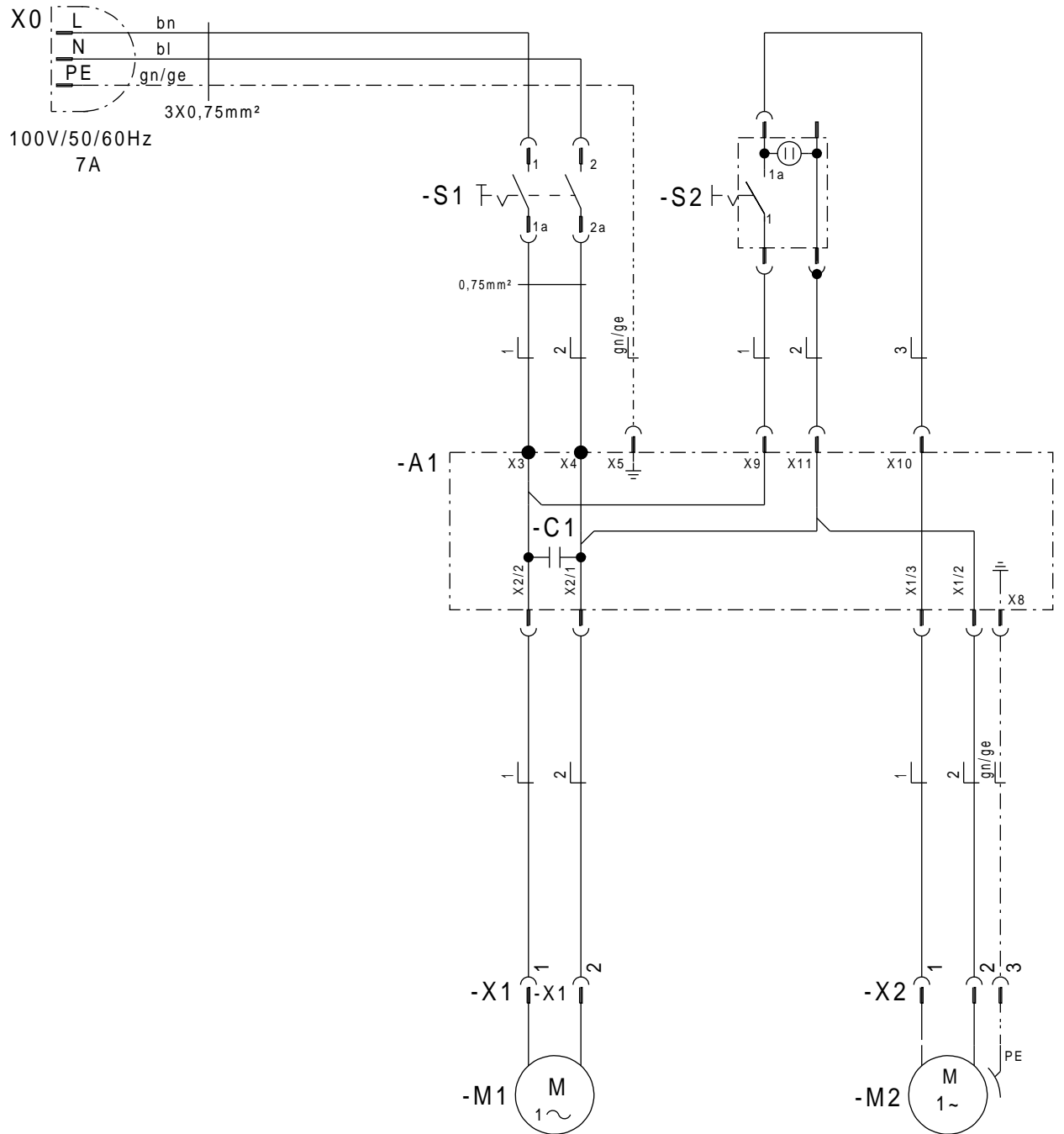

A1	Distribution board
C1	De-interference capacitor, 0,22 $\mu$ F
M1	Brush motor
M2	Water pump
S1	Main switch for brushing/vacuuming operations
S2	Water pump switch
X0	Mains plug
X1	Connector 2 pin
X3	Connector 3 pin

## 7.4 Circuit diagram 0.089-305.0 - BR 30/4 C Bp Pack

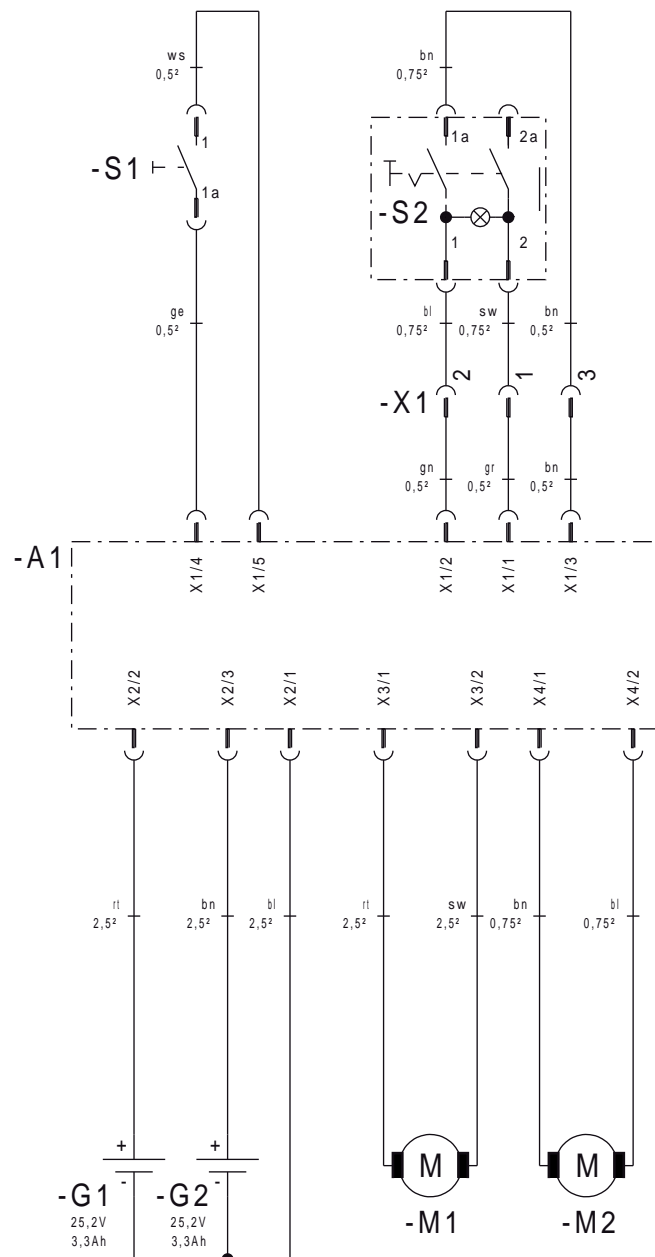
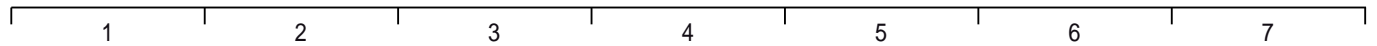

A1	Control board
G1/ G2	Batteries (25.2 V / 3.3 Ah)
M1	Brush motor
M2	Water pump
S1	Main switch for brushing/vacuuming operations
S2	Water pump switch
X0	Mains plug
X1	Connector 3 pin

## 8 Technical specifications

### 8.1 BR 30/4 C - power models

<b>Power</b>		
Nominal voltage	V	220...240
Frequency	Hz	1~ 50/60
Average power consumption	W	820
Protective class		I
Type of protection		IPX4
<b>Current pickup</b>		
230 V / 50 Hz	A	2,9 - 3,5
230 V / 60 Hz	A	2,9 - 3,4
120 V / 60 Hz	A	5,6 - 6,3
100 V / 50/60 Hz	A	6,4 - 7,2
<b>Vacuuming</b>		
Cleaning power, air quantity	l/s	26
Cleaning power, negative pressure	kPa	13
Suction power with suction lips on the floor	kPa	5 - 6
<b>Cleaning brush</b>		
Working width	mm	300
Brush diameter	mm	60
Brush speed	1/min	1450
<b>Dimensions and weights</b>		
Theoretical surface cleaning performance	m <sup>2</sup> /h	200
Max. water volume	ml/min	270 - 300
Fresh/dirt water reservoir volume	l	4
Length x width x height	mm	390 x 335 x 1180
Transport weight	kg	12
Total weight	kg	16
<b>Values determined as per EN 60335-2-67</b>		
Hand-arm vibration value	m/s <sup>2</sup>	<2,5
Uncertainty K	m/s <sup>2</sup>	0,2
Sound pressure level L <sub>pA</sub>	dB(A)	72
Uncertainty K <sub>pA</sub>	dB(A)	1
Sound pressure level L <sub>WA</sub>	dB(A)	85
Uncertainty K <sub>WA</sub>	dB(A)	1

### 8.2 BR 30/4 C Bp Pack

<b>Power</b>		
Nominal voltage	V	25,2
Nominal capacity	Ah	3,3
Average power consumption	W	550
Protective class		III
Type of protection		IPX4
<b>Current pickup</b>		
Total appliance 25.2 V	A	19 - 23
Pump	A	1
Pump overload	A	2,6
<b>Vacuuming</b>		
Cleaning power, air quantity	l/s	23
Suction power, max. negative pressure	kPa	10 - 12
Suction power with suction lips on the floor	kPa	5 - 6
<b>Cleaning brush</b>		
Working width	mm	300
Brush diameter	mm	60
Brush speed	1/min	1270
<b>Dimensions and weights</b>		
Theoretical surface cleaning performance	m <sup>2</sup> /h	200
Max. water volume	ml/min	240 - 270
Fresh/dirt water reservoir volume	l	4
Length x width x height	mm	390 x 335 x 1180
Transport weight	kg	14,5
Total weight	kg	18,5
<b>Values determined as per EN 60335-2-72</b>		
Hand-arm vibration value	m/s <sup>2</sup>	<2,5
Uncertainty K	m/s <sup>2</sup>	0,2
Sound pressure level L <sub>pA</sub>	dB(A)	69
Uncertainty K <sub>pA</sub>	dB(A)	1
Sound pressure level L <sub>WA</sub>	dB(A)	84
Uncertainty K <sub>WA</sub>	dB(A)	1
Battery life up to 20 minutes with two batteries		

### 8.3 Exchange times

Wear parts	Exchange time in minutes
Brush roller	1
Toothed belt from the turbine to the coupling and from the coupling to the brush roller	25
coupling	25
Pump	15
Standard turbine (is also the brush roller drive)	40
Seal ring (Nilos ring) brush roller bearing (the complete drive is offered as a spare parts kit)	10
Water distribution bar	1
Flexible suction hose between the main body and the brush head	20
Vacuum bar	1
Suction channel	20
Suction hose	20
Main switch	5
Pump switch	5
Power cord	15
Wheels	5
Floater in the wastewater reservoir	2
Floater seal	2
Seal in wastewater reservoir	3
Pluggable valve, fresh water	1
Complete handle	20
Tank, frame	
Control for Bp Pack model	15

### 8.4 Tightening torques

All screws

Nm 1,8 - 2

### 8.5 Special tools

There are no special tools necessary.

## 9 Documents

Appliance type	Appliance no.:	Circuit diagram	operating instructions	Spare parts list
BR 30/4 *EU	1.783-200.0	0.089-099.0	5.962-364.0	5.970-925.0
BR 30/4	1.783-202.0	0.089-149.0	5.962-037.0	5.970-925.0
BR 30/4 *JP	1.783-203.0	0.089-150.0	5.962-064.0	5.970-925.0
BR 30/4 *JP	1.783-204.0	0.089-150.0	5.962-064.0	5.970-925.0
BR 30/4 Adv *EU	1.783-205.0	0.089-099.0	5.962-364.0	5.970-925.0
BR 30/4 C *GB	1.783-207.0	0.089-099.0	5.962-364.0	5.970-925.0
BR 30/4 C Bp Pack *EU	1.783-208.0	0.089-305.0	5.963-616.0	5.971-230.0
BR 30/4 C Bp Pack	1.783-209.0	0.089-305.0	5.963-616.0	5.971-230.0
BR 30/4 C Bp Pack *JP	1.783-210.0	0.089-305.0	5.963-616.0	5.971-230.0
BR 30/4 C "Jubilee" *EU	1.783-211.0	0.089-099.0	5.962-364.0	5.970-925.0
BR 4,300	1.783-212.0	0.089-099.0	5.693-829.0	5.971-269.0

The technical specification sheet and the circuit diagram will be included in the next version of the spare parts CD (DISIS) and in the Intranet.

The operating instructions and the spare parts list can be requested in paper form with the respective part numbers from our spare parts service department.