

## **Spare parts list**

(1.127-001.0) BD 50/50 C Bp Classic

## Table of contents

---

BD 50/50 C Bp Classic (1.127-001.0)	3
10 Tank complete B 50 BP	6
10 Fresh water tank replacement BD50Bp (9.755-622.0)	12
30 Label with clamp signet XL (4.385-004.0)	13
30 Cap of a tank waste water replacement (9.755-479.0)	14
70 Float regulator complete (9.753-001.0)	16
120 Ball valve complete B50 CS ALA (9.753-002.0)	18
120 Solenoid valve complete replacement BD25+50 24V (9.753-101.0)	20
140 Drain hose with cover replacement (9.755-638.0)	22
20 Electronics complete BP B50 (9.753-087.0)	24
40 Gear motor replacement 24V Hengye (9.755-519.0)	27
80 Carriage B50 CS (9.753-003.0)	28
90 Control panel B50 CS (9.753-008.0)	30
100 Brush-head B50 CS	32
40 Disc brush complete nature D51 (4.905-027.0)	36
40 Disc brush complete white D51 (4.905-028.0)	38
40 Disc brush complete black D51 (4.905-029.0)	40
40 Disc brush complete red D51 (9.753-021.0)	42
110 Suction bar lifting cpl. fix (9.753-213.0)	43
9000 Holder suction bar complete	45
20 Holder suction bar (4.037-137.3)	47
120 Retainer turbine complete B50 CS (9.753-004.0)	49
180 Add-on kit drain hose ball valve BD 50 (2.643-986.0)	52
9000 Suction bar straight 850mm (4.777-401.0)	54
10 Suction bar pre-assembled straight 850mm (4.035-301.0)	56
9000 Conversion kit support roller deep (4.035-281.0)	58
9000 Roller suction bar (4.035-339.0)	60
9002 BLADES FOR TEXTURED FLOORS (6.273-290.0)	62
9000 Suction bar curved 850mm (4.777-411.0)	63
10 Suction bar pre-assembled curved 850mm (4.035-311.0)	65
9000 Conversion kit support roller deep (4.035-281.0)	67
9000 Roller suction bar (4.035-339.0)	69
9002 BLADES FOR TEXTURED FLOORS (6.273-290.0)	71
9001 Add-on kit carriage roller (2.643-723.0)	72
10 Roller complete (9.753-049.0)	74
9500 Mop holder complete (9.753-023.0)	77
9532 Mounting kit battery kit (2.638-036.0)	79
9542 Mounting kit battery kit (2.638-144.0)	80

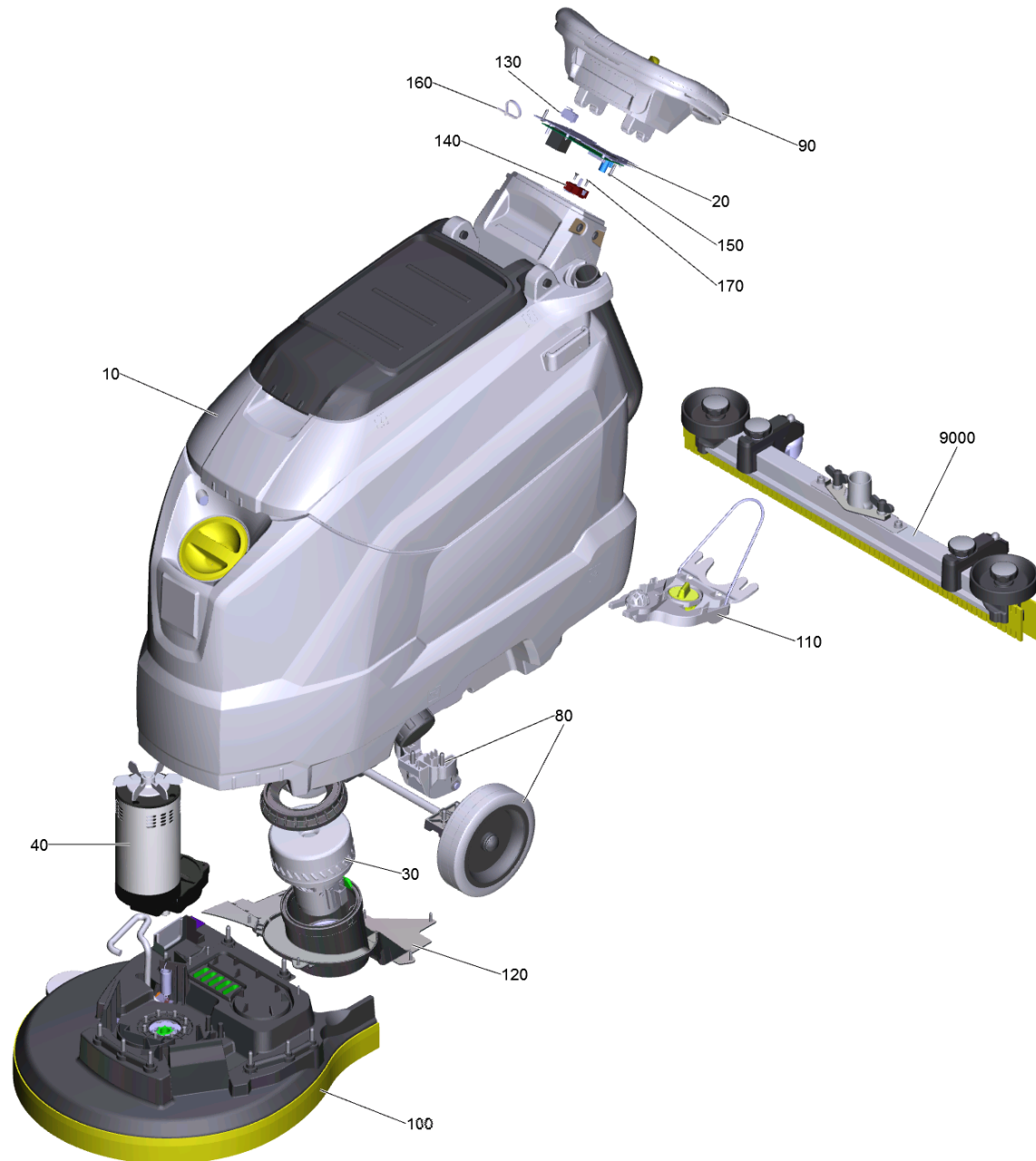

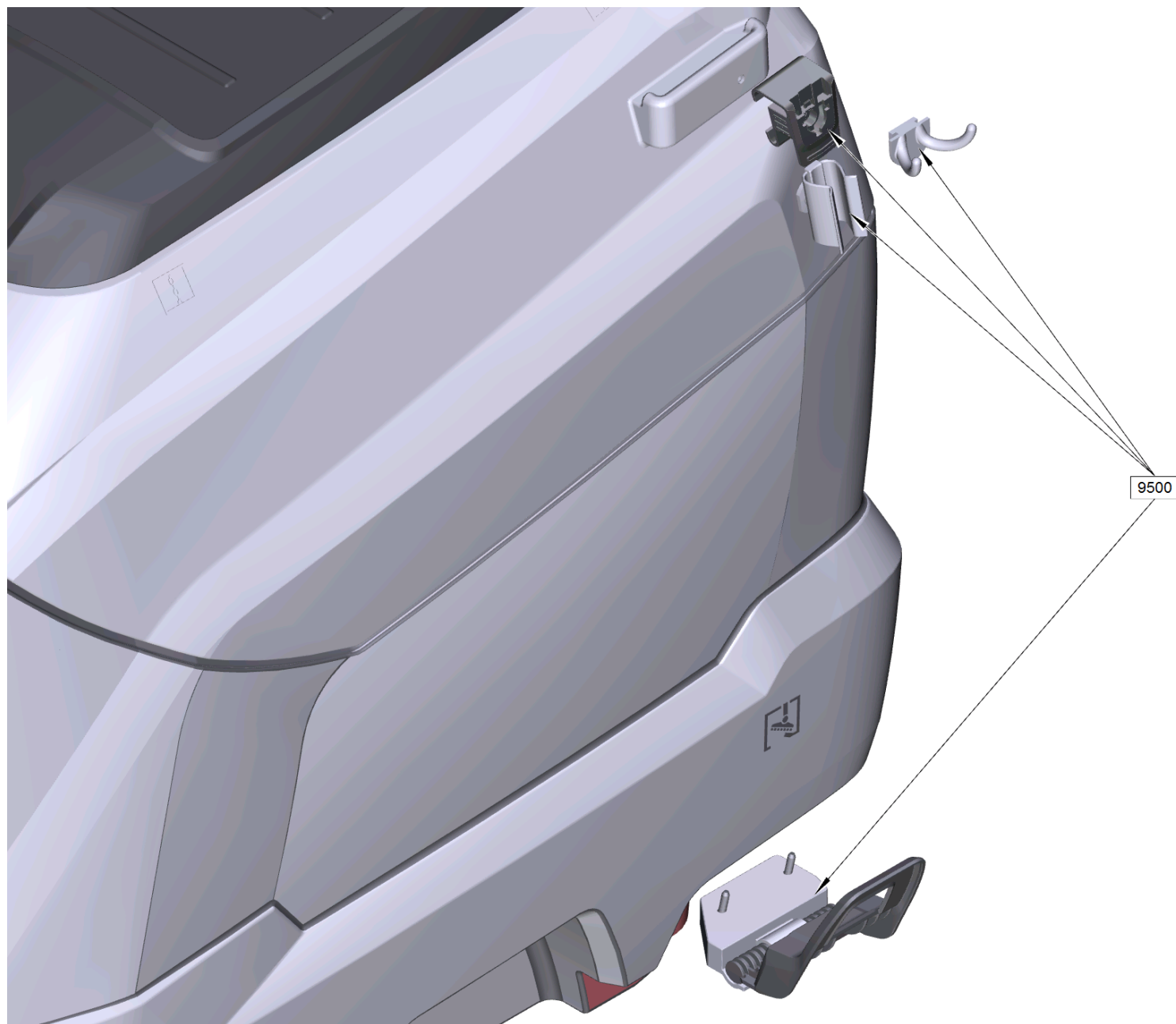

## BD 50/50 C Bp Classic (1.127-001.0)

POS	Article no.	Description	Quantity	Unit
10		Tank complete B 50 BP	1.000	ST
20	9.753-087.0	Electronics complete BP B50	1.000	ST
30	4.035-580.0	Vacuum motor replacement	1.000	ST
40	9.755-519.0	Gear motor replacement 24V Hengye	1.000	ST
75	9.763-222.0	Distance holder batterys	2.000	ST
80	9.753-003.0	Carriage B50 CS	1.000	ST
90	9.753-008.0	Control panel B50 CS	1.000	ST
100		Brush-head B50 CS	1.000	ST
110	9.753-213.0	Suction bar lifting cpl. fix	1.000	ST
120	9.753-004.0	Retainer turbine complete B50 CS	1.000	ST
130	9.763-051.0	Micro switch Bp	1.000	ST
140	9.755-493.0	Switch coding replacement 24V	1.000	ST
150	7.303-108.0	Screw 5x20 -10.9-R2R (In6Rd)	2.000	ST
160	6.594-709.0	Cable tie	1.000	ST
170	7.305-036.0	Countersunk screw M4x12 -A2-70-s (IN6RD)	2.000	ST
180	2.643-986.0	Add-on kit drain hose ball valve BD 50	1.000	ST
1050		Documentation B 50 C Bp	1.000	ST
9000	4.777-401.0	Suction bar straight 850mm	1.000	ST
9000	4.777-411.0	Suction bar curved 850mm	1.000	ST
9001	2.643-723.0	Add-on kit carriage roller	1.000	ST
9500	9.753-023.0	Mop holder complete	1.000	ST
9530	2.815-099.0	Battery kit Gel 2x 12V/76Ah	1.000	SET
9531	2.815-100.0	Battery kit Gel 2x 12V/105Ah	1.000	SET
9532	2.638-036.0	Mounting kit battery kit	1.000	ST
9540	2.815-090.0	Battery kit AGM 2x 12V/80Ah	1.000	SET
9541	2.815-091.0	Battery kit AGM 2x 12V/115Ah	1.000	SET
9542	2.638-144.0	Mounting kit battery kit	1.000	ST

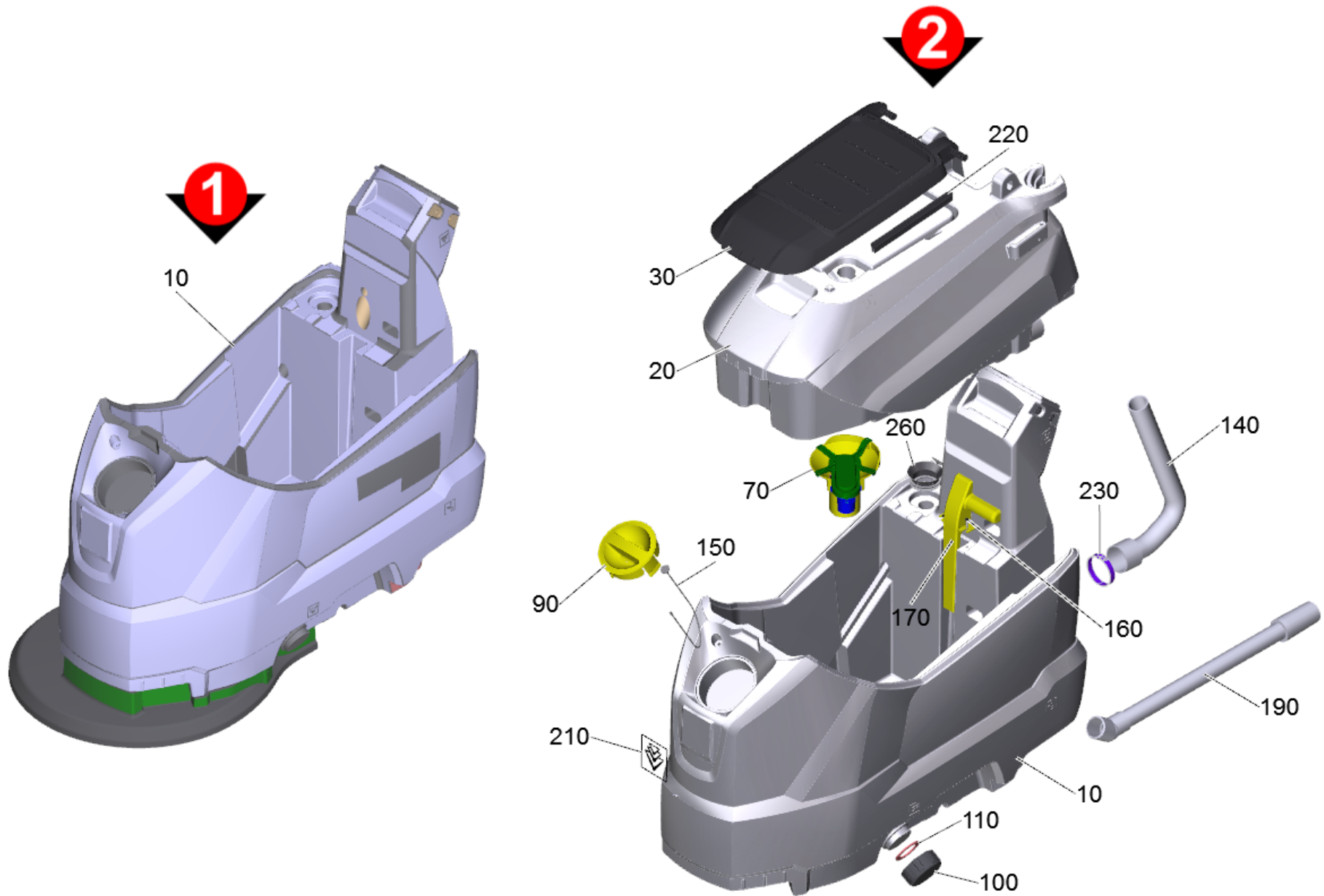

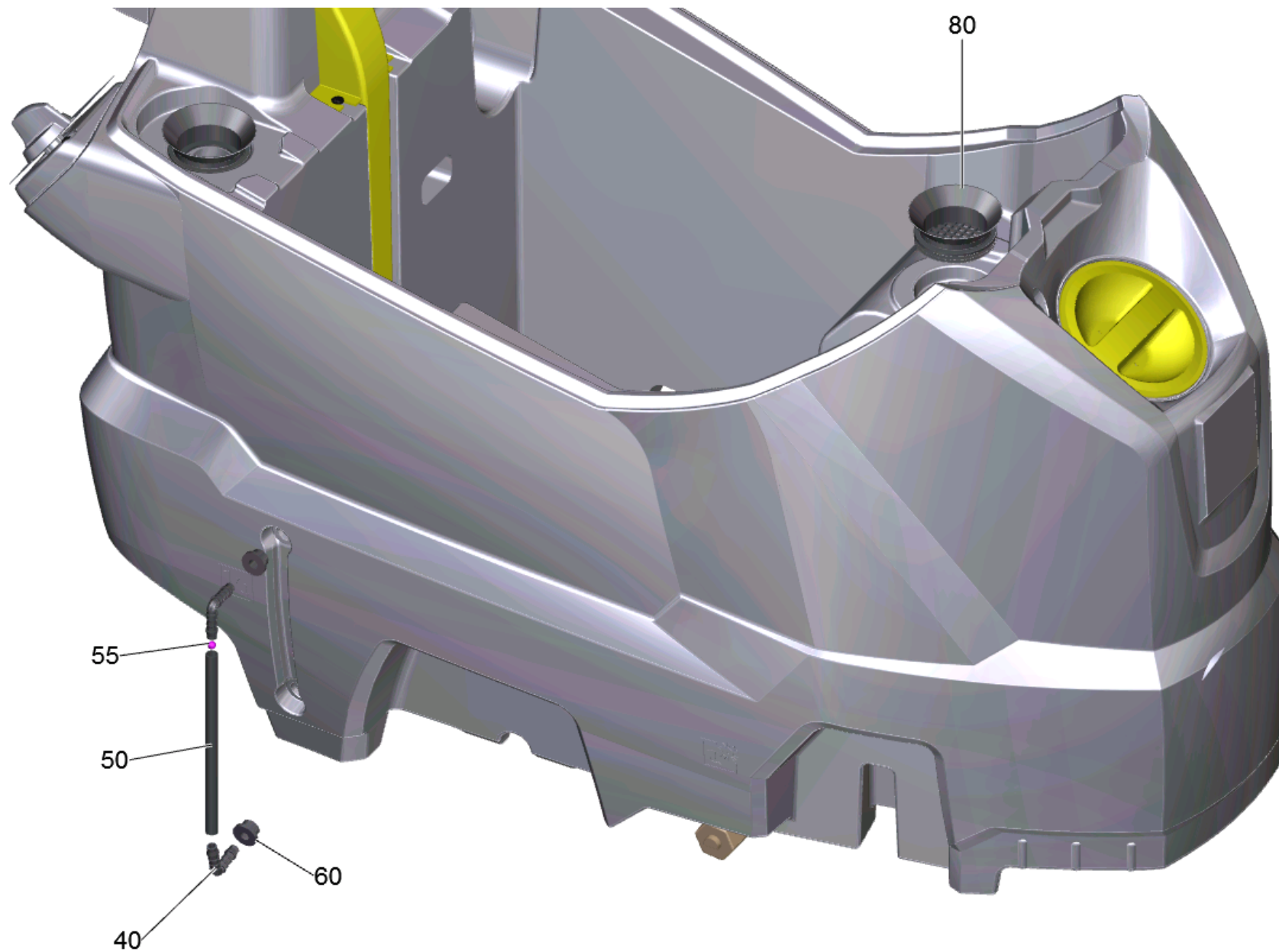

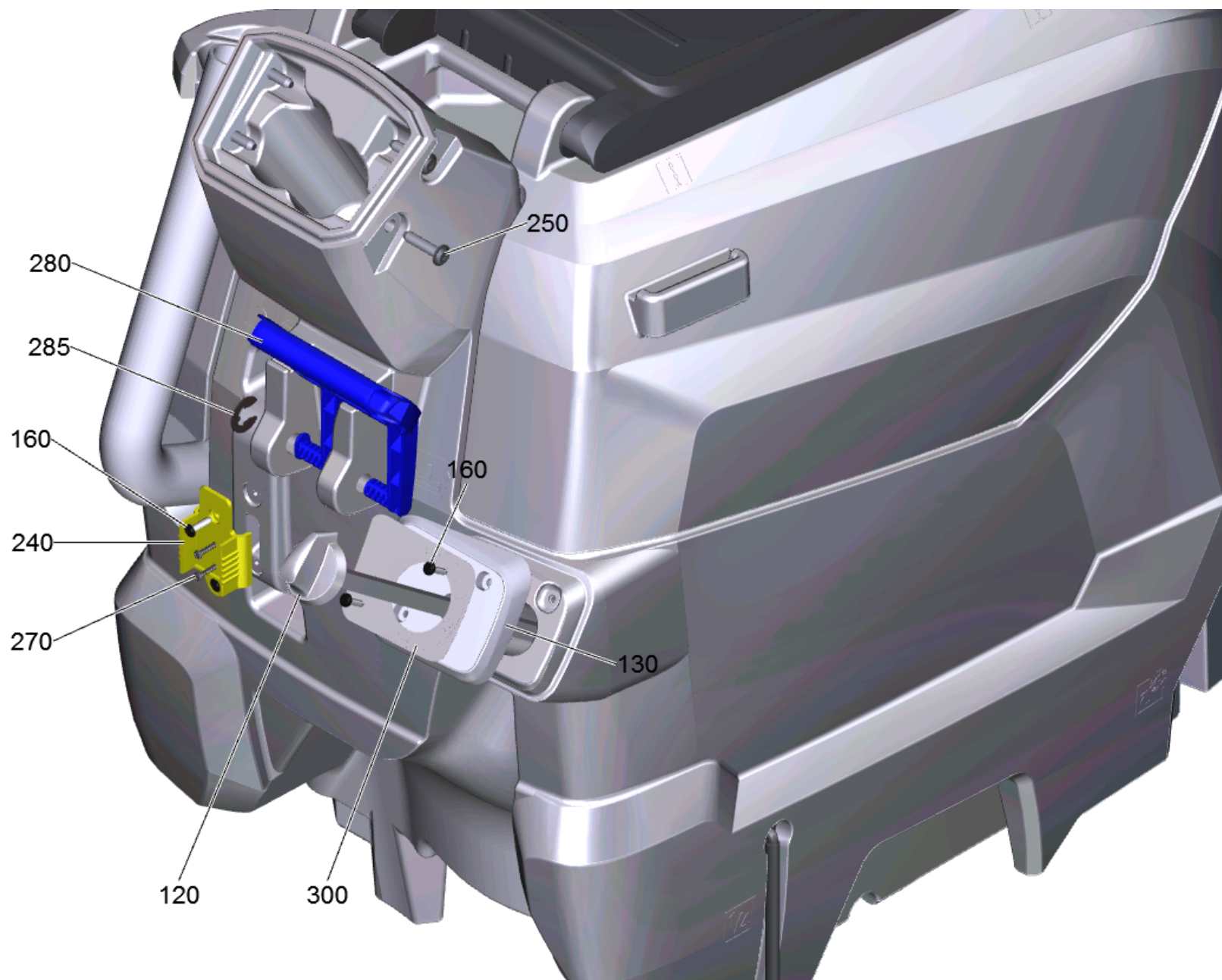



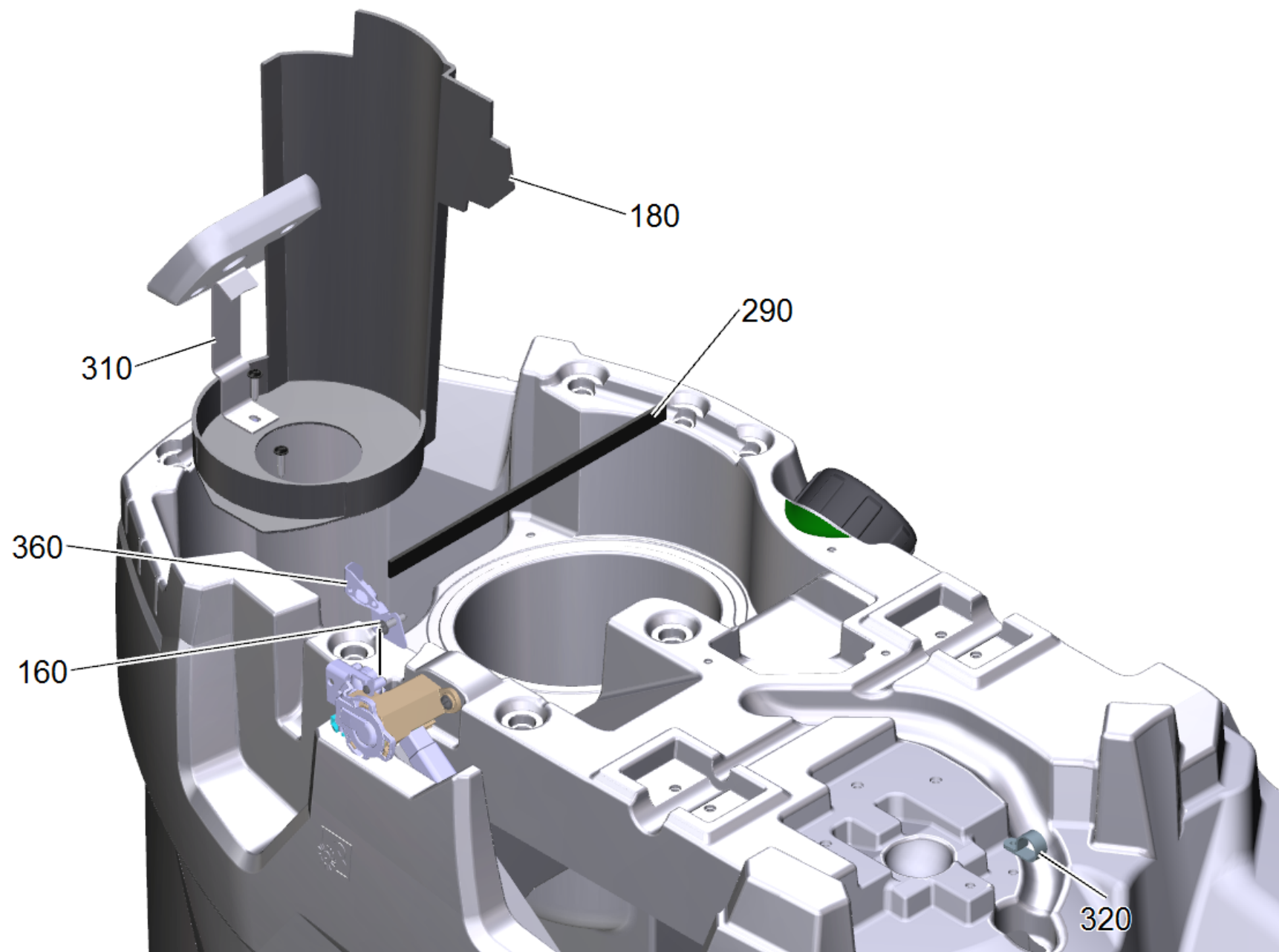

## 10 Tank complete B 50 BP

POS	Article no.	Description	Quantity	Unit	Foot note text
10	9.755-620.0	Brush deck tank replacement BD50Bp	1.000	ST	VERSION 1: FOR MACHINES WITHOUT SOLENOID VALVE
10	9.755-622.0	Fresh water tank replacement BD50Bp	1.000	ST	VERSION 2: FOR DEVICES WITH SOLENOID VALVE
20	9.755-478.0	Waste water tank replacement B 50	1.000	ST	
30	9.755-479.0	Cap of a tank waste water replacement	1.000	ST	
40	6.391-913.0	Elbow nipple	2.000	ST	
50	9.763-068.0	Silicon hose level indicator	1.000	ST	
55	6.035-072.0	Sphere level indicator D6	1.000	ST	
60	5.035-608.0	Wire protecting sleeve	2.000	ST	
70	9.753-001.0	Float regulator complete	1.000	ST	
80	9.763-012.0	Seal turbine strainer	1.000	ST	
90	5.034-099.0	Cover fresh water metering RM	1.000	ST	
100	9.763-007.0	Cover fresh water tank	1.000	ST	
110	9.763-008.0	Seal fresh water discharge	1.000	ST	
120	9.753-002.0	Ball valve complete B50 CS ALA	1.000	ST	VERSION 1: FOR MACHINES WITHOUT SOLENOID VALVE
120	9.753-101.0	Solenoid valve complete replacement BD25+50 24V	1.000	ST	VERSION 2: FOR DEVICES WITH SOLENOID VALVE
130	9.755-480.0	Covering cap ball valve replacement	1.000	ST	
140	9.755-638.0	Drain hose with cover replacement	1.000	ST	
150	5.035-358.0	Mounting rope cover fresh water tank	1.000	ST	
160	7.303-108.0	Screw 5x20 -10.9-R2R (In6Rd)	10.000	ST	
170	9.763-035.0	Cable support	1.000	ST	
180	9.763-036.0	Dividing wall motor air circulation	1.000	ST	
190	9.763-037.0	Suction hose DN32	1.000	ST	
210	5.394-081.0	Label signet gel 78x86	1.000	ST	
220	9.755-482.0	Sealing profile replacement	1.000	ST	
230	6.388-713.0	Hose clip	1.000	ST	
240	9.763-045.0	Retainer battery plug Anderson	1.000	ST	
250	6.303-315.0	Screw 8 x 35	4.000	ST	
260	9.763-043.0	Seal suction bar air	1.000	ST	
270	7.303-084.0	Screw 4x25 -10.9-R2R (K-In6Rd)	2.000	ST	
280	9.763-041.0	Lever suction beam retraction	1.000	ST	
285	9.763-079.0	Lock washer	1.000	ST	
290	9.755-483.0	Sealing tape cellularrubber replacement	1.000	ST	
300	9.763-060.0	Label water regulation	1.000	ST	

## 10 Tank complete B 50 BP

---

<b>POS</b>	<b>Article no.</b>	<b>Description</b>	<b>Quantity</b>	<b>Unit</b>	<b>Foot note text</b>
310	9.763-040.0	Retaining plate motor BD 50CS	1.000	ST	
320	6.373-876.0	Hose clip 17.5	1.000	ST	
360	9.763-369.0	Retaining plate solenoid valve BD50 25	1.000	ST	

10 Fresh water tank replacement BD50Bp (9.755-622.0)

---

<b>POS</b>	<b>Article no.</b>	<b>Description</b>	<b>Quantity</b>	<b>Unit</b>
20	5.385-513.0	Label logo glued XL Professional	2.000	ST
30	4.385-004.0	Label with clamp signet XL	1.000	ST

30 Label with clamp signet XL (4.385-004.0)

---

<b>POS</b>	<b>Article no.</b>	<b>Description</b>	<b>Quantity</b>	<b>Unit</b>
1	6.385-523.0	Clamp	5.000	ST



30 Cap of a tank waste water replacement (9.755-479.0)

---

<b>POS</b>	<b>Article no.</b>	<b>Description</b>	<b>Quantity</b>	<b>Unit</b>
20	9.755-482.0	Sealing profile replacement	1.000	ST

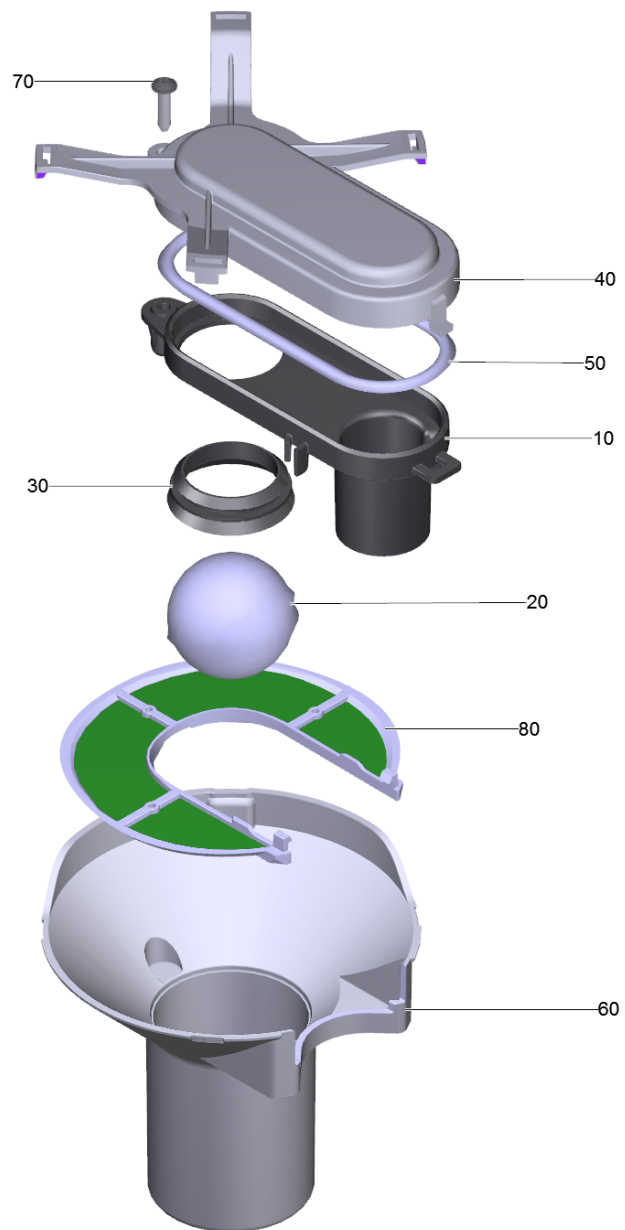



## 70 Float regulator complete (9.753-001.0)

---

<b>POS</b>	<b>Article no.</b>	<b>Description</b>	<b>Quantity</b>	<b>Unit</b>
10	9.763-003.0	Float regulator bottom part	1.000	ST
20	9.763-333.0	Floater ball	1.000	ST
30	9.763-004.0	Seal float regulator	1.000	ST
40	9.763-005.0	Cover float regulator	1.000	ST
50	9.763-044.0	Seal string cellular rubber float regula	1.000	ST
60	9.763-047.0	Float cage	1.000	ST
70	7.303-108.0	Screw 5x20 -10.9-R2R (In6Rd)	1.000	ST
80	9.763-383.0	Strainer float regulator	1.000	ST

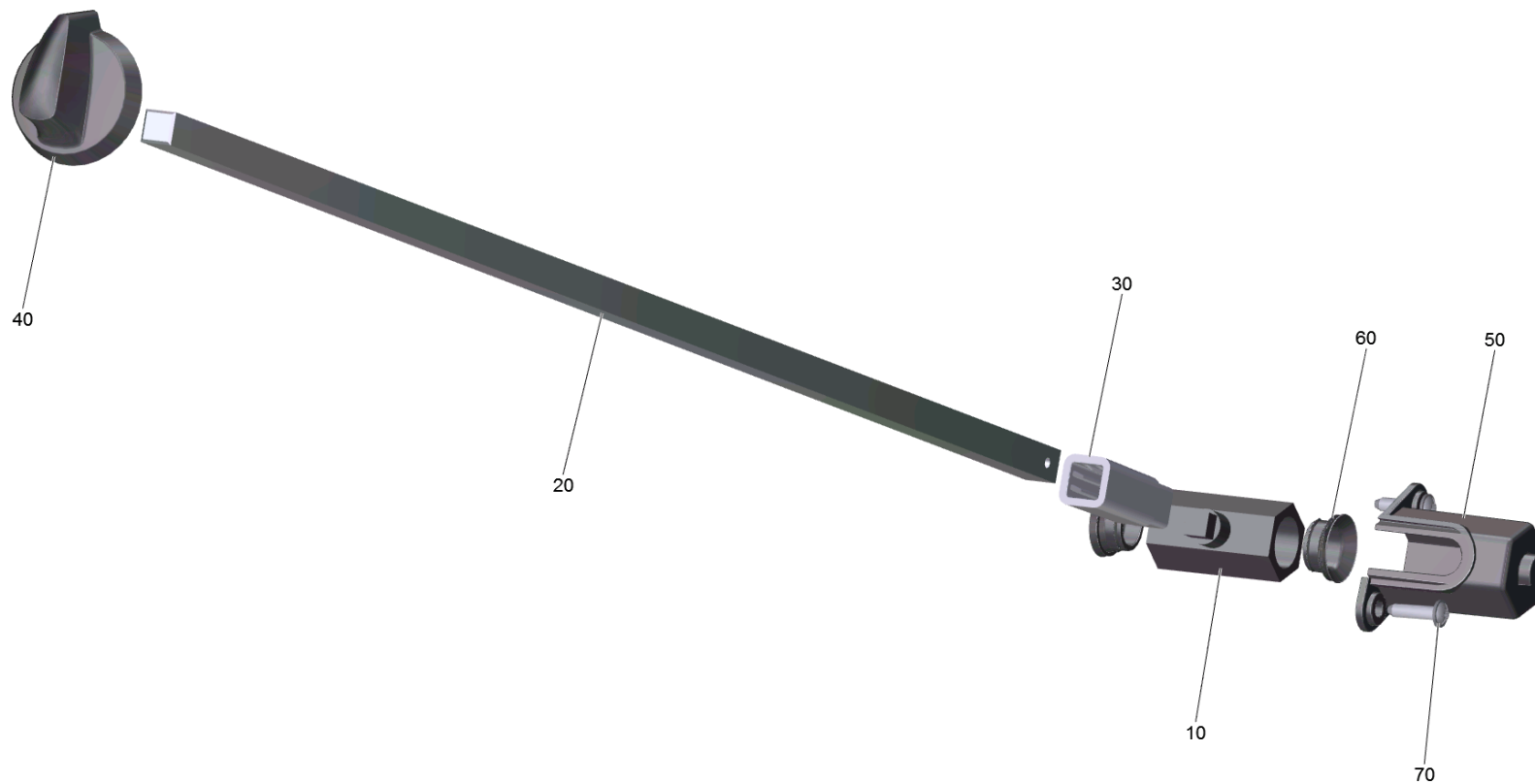

120 Ball valve complete B50 CS ALA (9.753-002.0)

---

<b>POS</b>	<b>Article no.</b>	<b>Description</b>	<b>Quantity</b>	<b>Unit</b>
10	6.413-586.0	Ball valve without handhold	1.000	ST
20	9.763-009.0	Bar ball valve	1.000	ST
30	5.035-459.0	Coupler piece ball valve	1.000	ST
40	5.035-404.0	Handle	1.000	ST
50	9.763-184.0	Holder ball valve B 25	1.000	ST
60	9.763-011.0	Seal ball valve	2.000	ST
70	7.303-108.0	Screw 5x20 -10.9-R2R (In6Rd)	2.000	ST

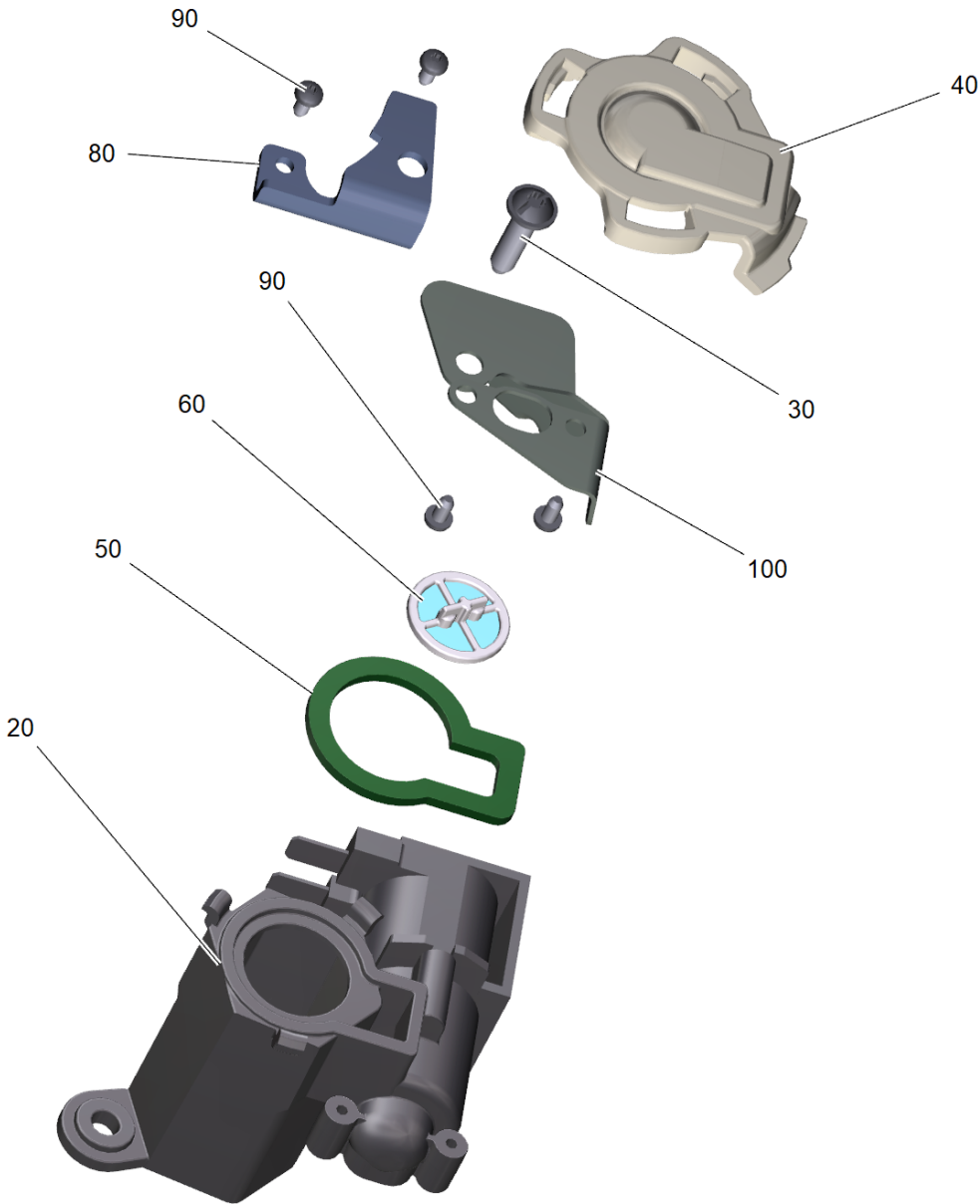

## 120 Solenoid valve complete replacement BD25+50 24V (9.753-101.0)

---

<b>POS</b>	<b>Article no.</b>	<b>Description</b>	<b>Quantity</b>	<b>Unit</b>
20	6.472-004.0	Solenoid valve 24V	1.000	ST
30	7.303-108.0	Screw 5x20 -10.9-R2R (In6Rd)	1.000	ST
40	5.037-510.0	Cover plate ball valve solenoid valve	1.000	ST
50	5.037-512.0	Seal cover solenoid valve	1.000	ST
60	5.037-511.0	Strainer solenoid valve	1.000	ST
80	9.763-384.0	Plate cover solenoid valve BD 50 25	1.000	ST
90	7.303-334.0	Screw 3x6 -A2-70 (In6Rd)	4.000	ST
100	9.763-369.0	Retaining plate solenoid valve BD50 25	1.000	ST

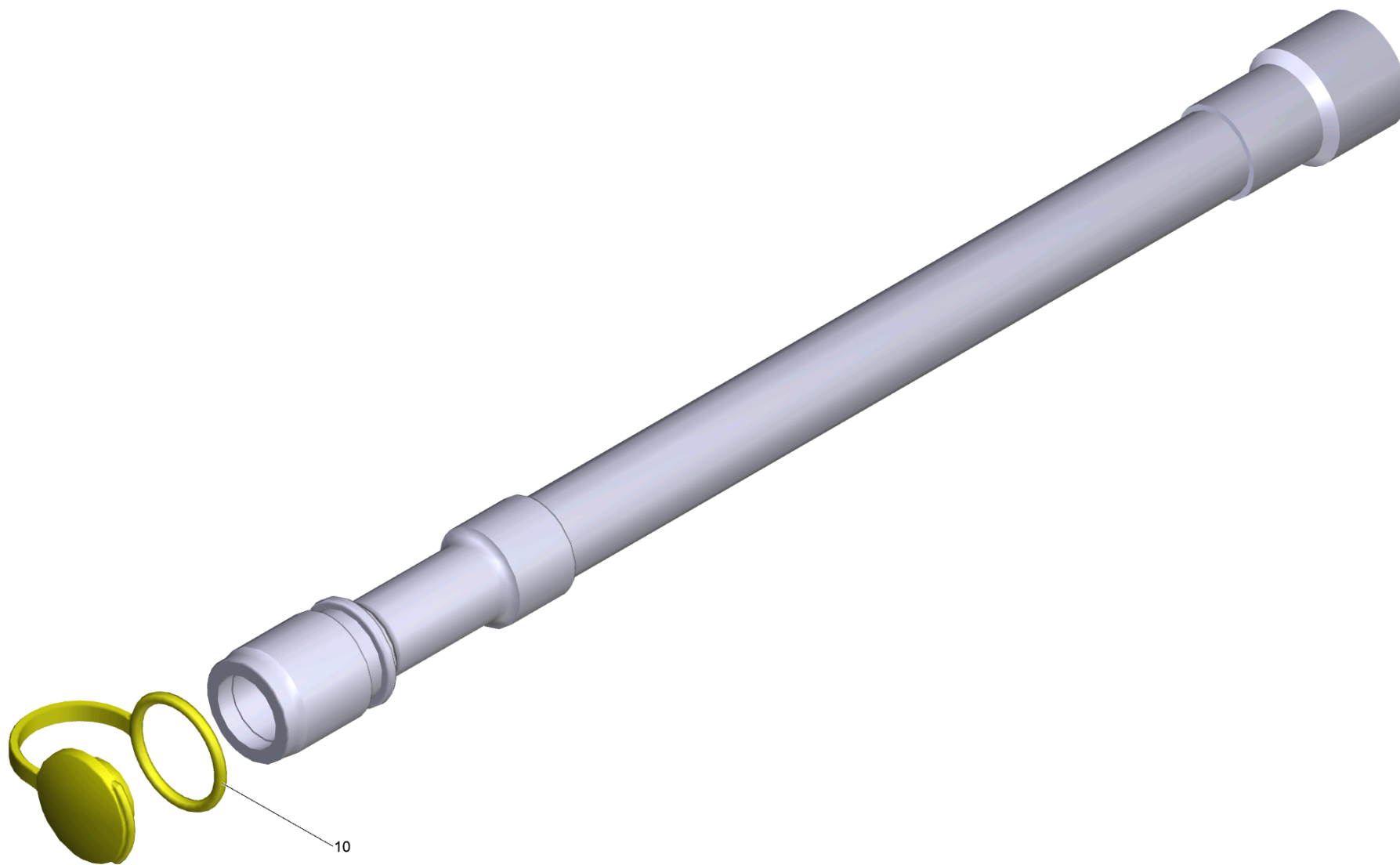

140 Drain hose with cover replacement (9.755-638.0)

---

<b>POS</b>	<b>Article no.</b>	<b>Description</b>	<b>Quantity</b>	<b>Unit</b>
10	5.035-815.0	Cover drain hose oil resistant	1.000	ST

---

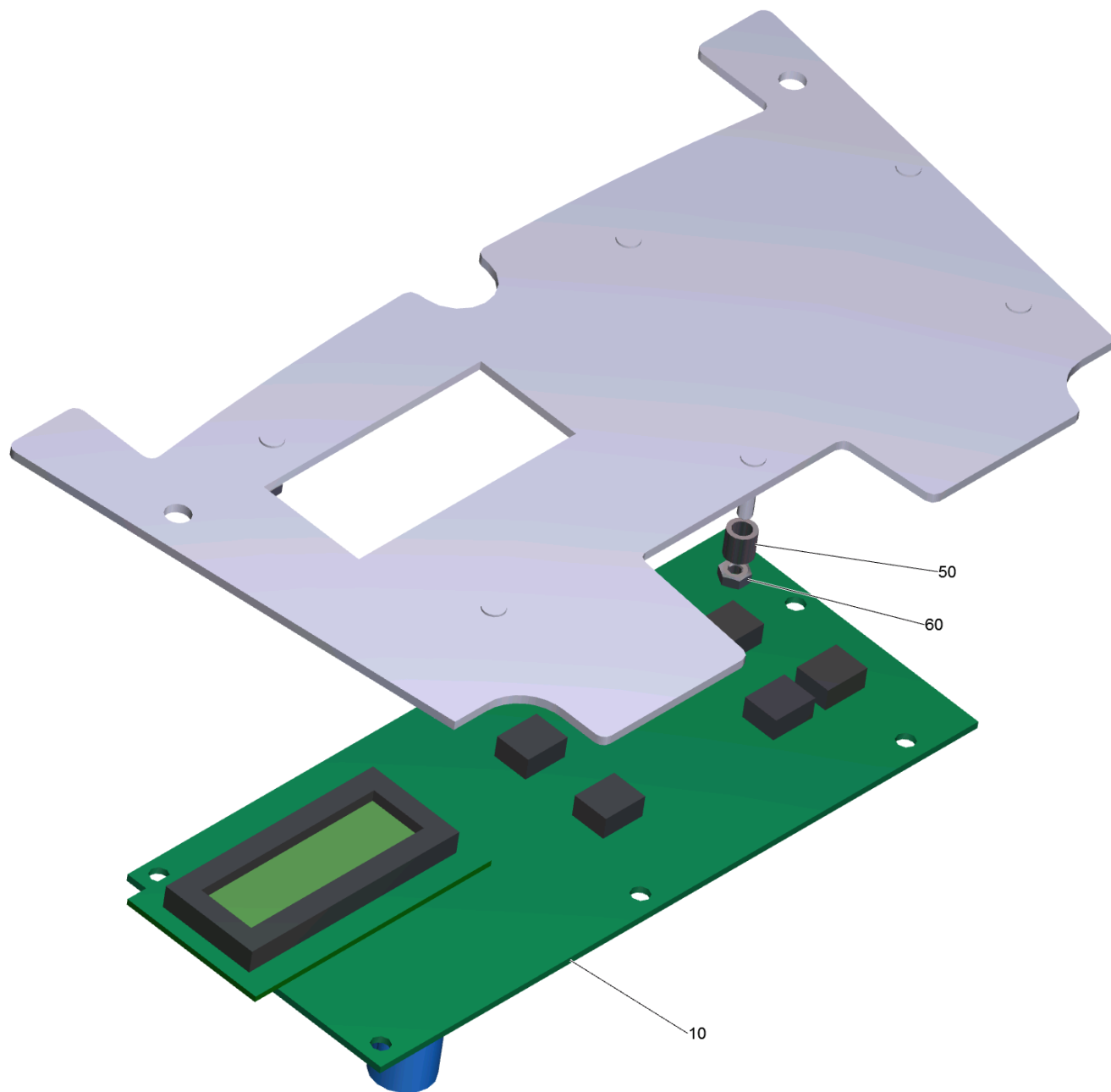



40

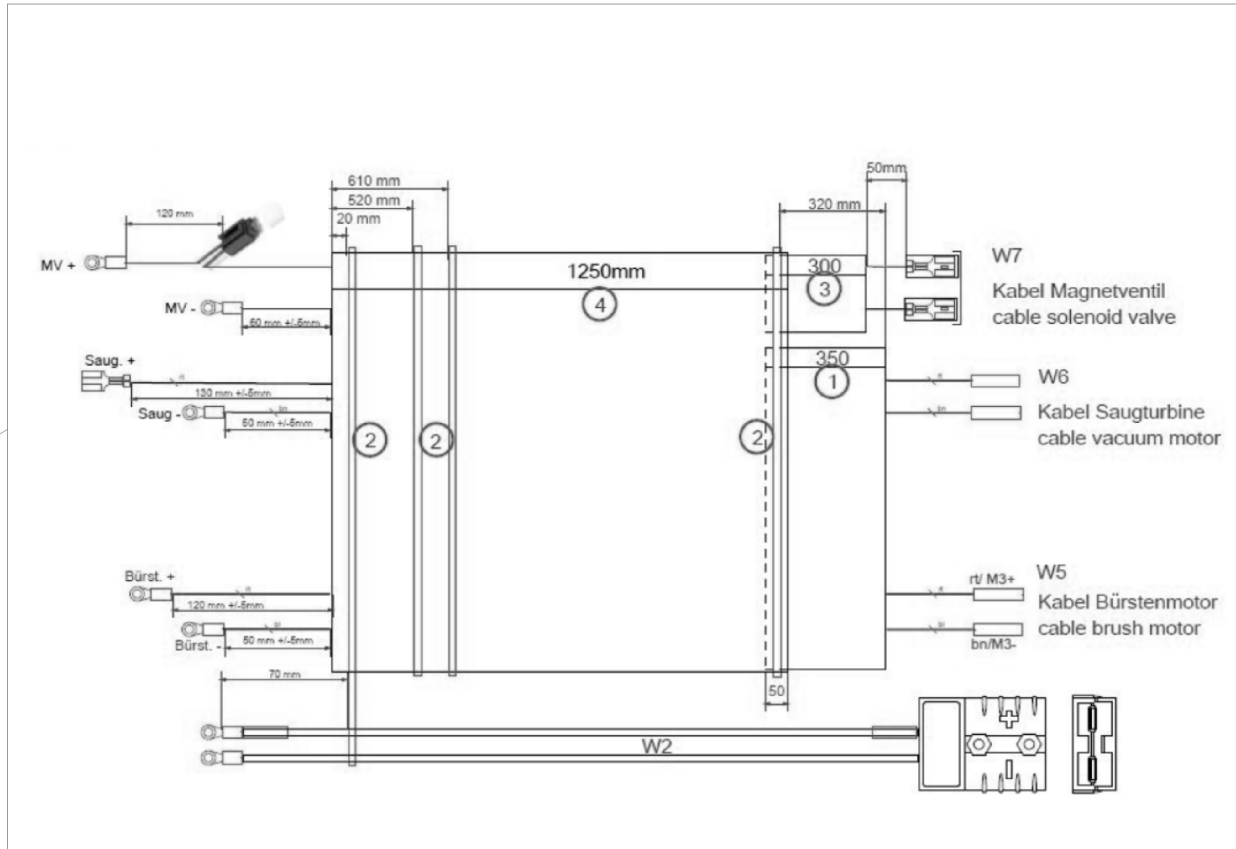

20 Electronics complete BP B50 (9.753-087.0)

---

<b>POS</b>	<b>Article no.</b>	<b>Description</b>	<b>Quantity</b>	<b>Unit</b>
10	9.755-484.0	Control circuit board replacement B 50 2	1.000	ST
40	9.753-208.0	Cable harness with solenoid valve B50 BP /B25 BP	1.000	ST
50	5.035-962.0	Sleeve	6.000	ST
60	7.311-000.0	Hexagon nut M3 -6-A2E ISO 4032	6.000	ST

40 Gear motor replacement 24V Hengye (9.755-519.0)

---

<b>POS</b>	<b>Article no.</b>	<b>Description</b>	<b>Quantity</b>	<b>Unit</b>
1	9.755-590.0	Carbon brush set Hengye 24V	1.000	ST
2	7.343-083.0	Locking ring 12x1 -FSt DIN 471	1.000	ST

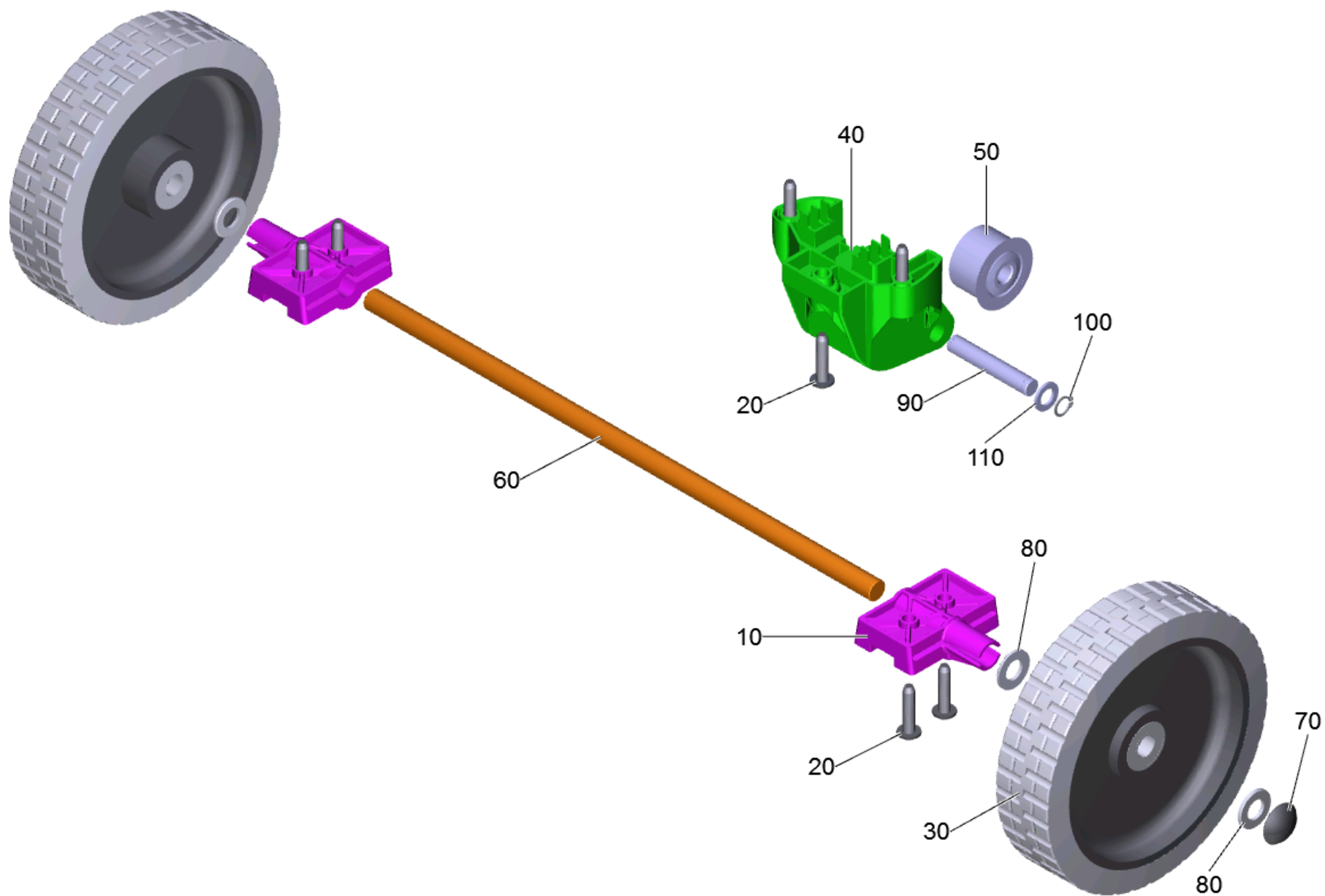

## 80 Carriage B50 CS (9.753-003.0)

POS	Article no.	Description	Quantity	Unit
10	9.763-015.0	Holder axle	2.000	ST
20	6.303-315.0	Screw 8 x 35	7.000	ST
30	9.763-081.0	Wheel D200	2.000	ST
40	9.763-016.0	Holder transport wheel	1.000	ST
50	9.763-053.0	Roller with ball bearing	1.000	ST
60	9.763-014.0	Axle	1.000	ST
70	6.343-240.0	Lock washer	2.000	ST
80	7.312-028.0	Washer 14-200HV-A3E ISO7089	4.000	ST
90	9.763-006.0	Axle tipping roll	1.000	ST
100	7.343-083.0	Locking ring 12x1 -FSt DIN 471	2.000	ST
110	7.312-075.0	Washer 12-CuZn ISO 7092	2.000	ST

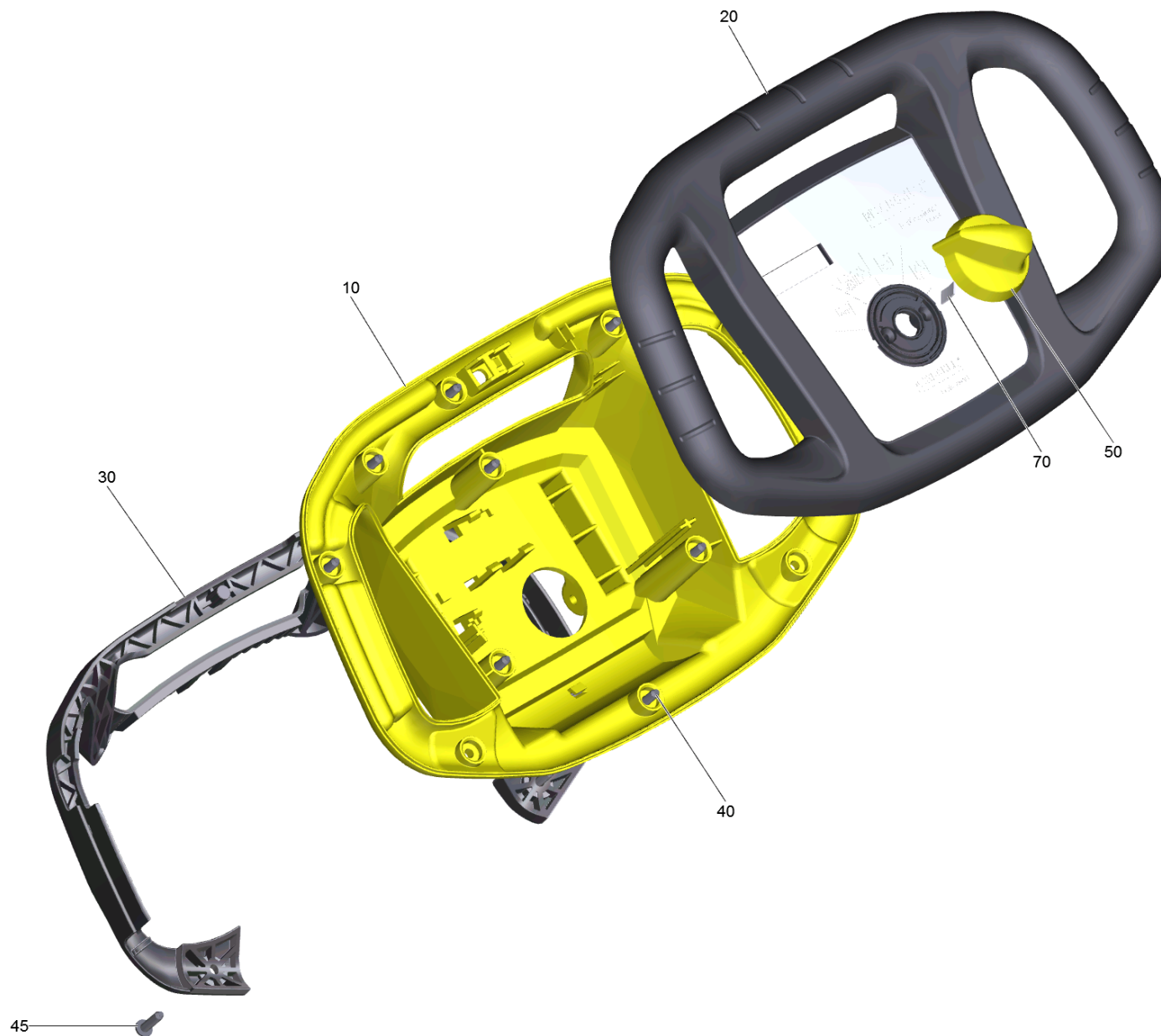

## 90 Control panel B50 CS (9.753-008.0)

---

<b>POS</b>	<b>Article no.</b>	<b>Description</b>	<b>Quantity</b>	<b>Unit</b>
10	9.755-490.0	Control panel bottom part replacement	1.000	ST
20	9.755-491.0	Control panel top part replacement	1.000	ST
30	9.763-029.0	Dead man's switch handhold	1.000	ST
40	7.303-108.0	Screw 5x20 -10.9-R2R (In6Rd)	11.000	ST
45	7.303-109.0	Screw 5x25 -10.9-R2R (In6Rd)	2.000	ST
50	5.321-738.0	Handhold operational concept	1.000	ST
70	6.313-014.0	Spring element	1.000	ST

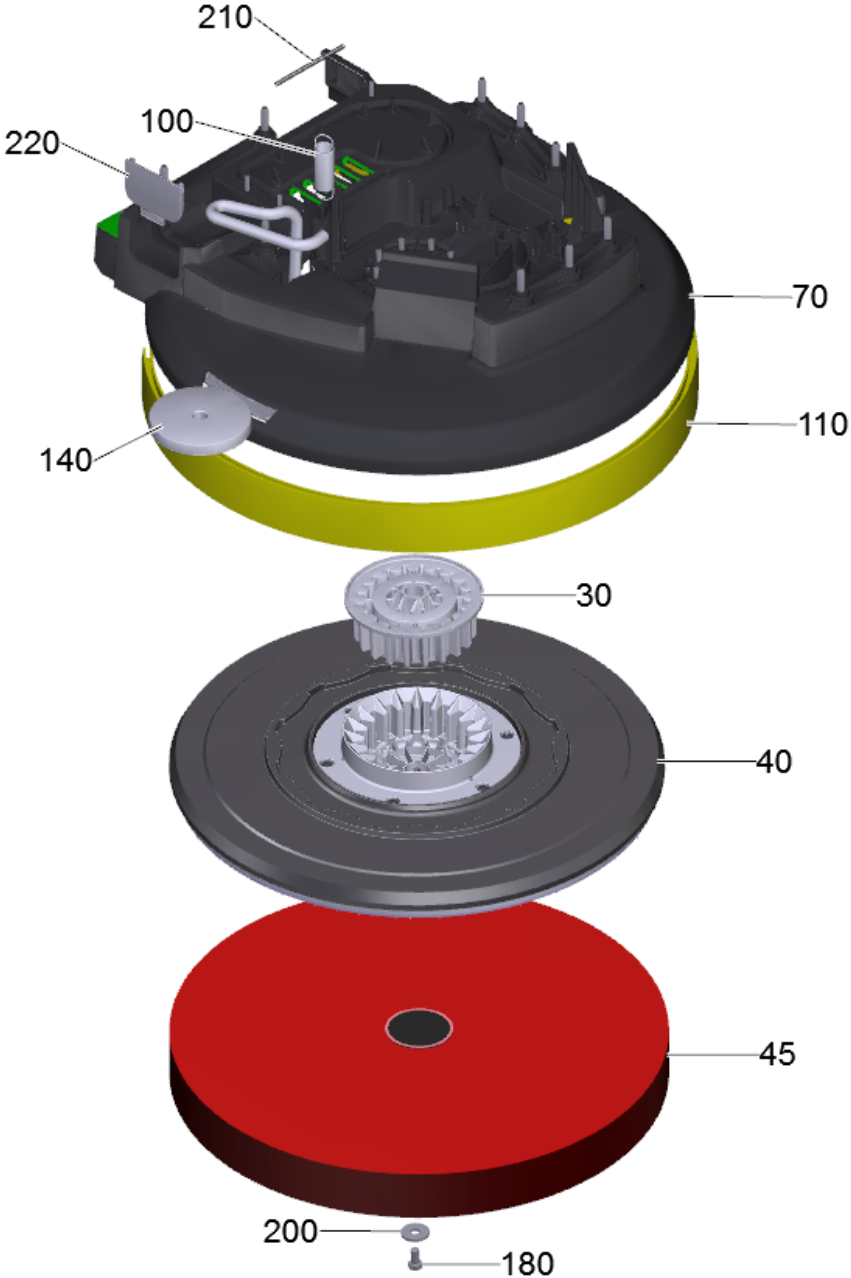



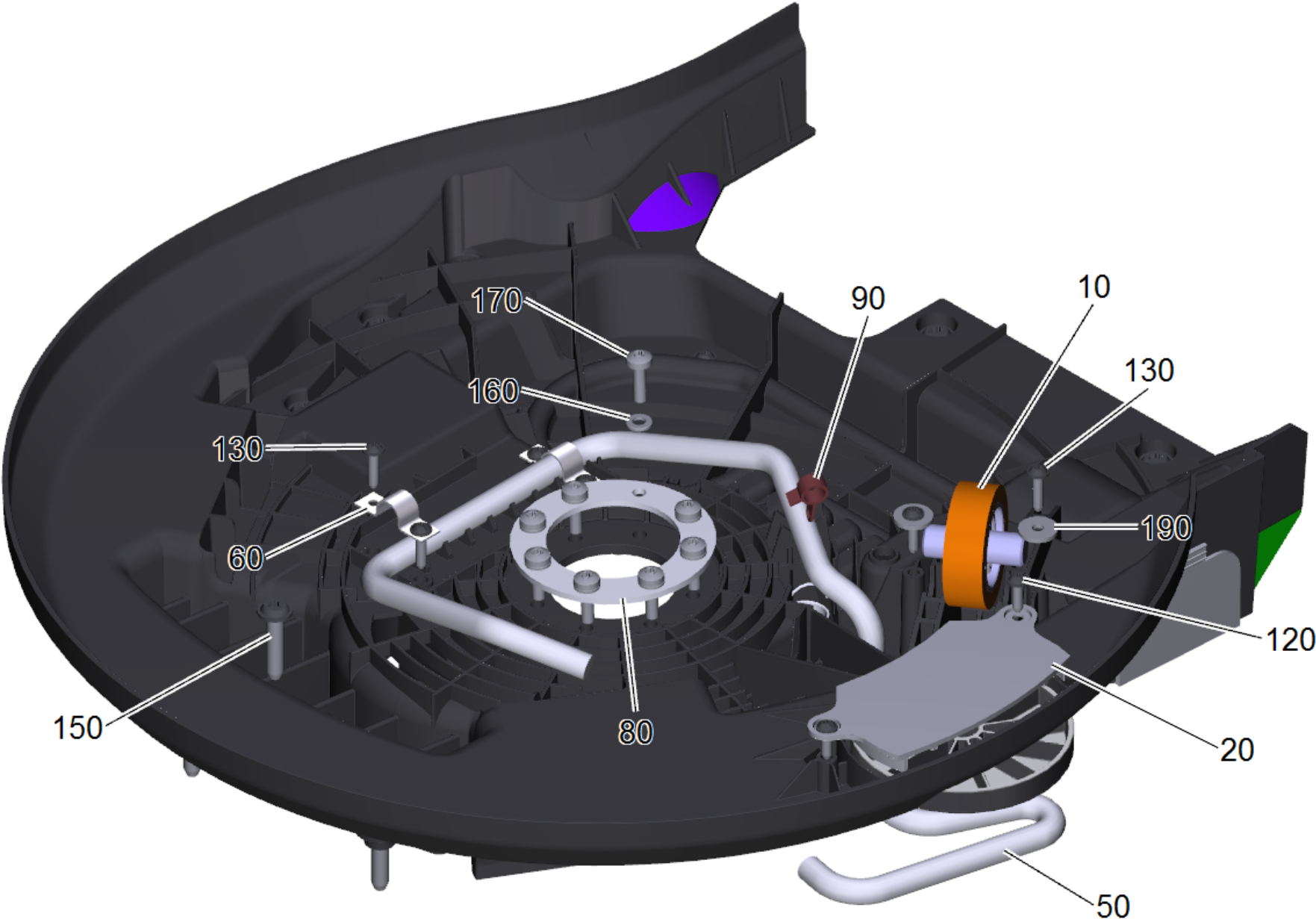

## 100 Brush-head B50 CS

POS	Article no.	Description	Quantity	Unit	Foot note text
10	9.753-006.0	Brush contact pressure complete	1.000	ST	
20	5.035-498.0	Fixing deflector roll	1.000	ST	
30	5.037-537.0	Retainer transmission	1.000	ST	
40	9.753-021.0	Disc brush complete red D51	1.000	ST	
40	4.905-029.0	Disc brush complete black D51	1.000	ST	
40	4.905-027.0	Disc brush complete nature D51	1.000	ST	
40	4.905-028.0	Disc brush complete white D51	1.000	ST	
50	9.763-023.0	Retaining bracket discharge	1.000	ST	
60	6.373-689.0	Pipe clamp	2.000	ST	
70	4.036-161.0	Covering cap brush-head for replacement	1.000	ST	VERSION 1: FOR MACHINES WITHOUT SOLENOID VALVE
70	9.755-640.0	Covering cap brush-head for replacement	1.000	ST	VERSION 2: FOR DEVICES WITH SOLENOID VALVE
80	5.039-179.0	Threaded plate	1.000	ST	
90	6.388-559.0	Hose clip	1.000	ST	
100	9.763-076.0	Extension spring	1.000	ST	
110	9.763-026.0	Splash-proof profile brush-head B50	1.000	ST	
120	7.303-107.0	Screw 5x16 -10.9-P2R (K-In6Rd)	2.000	ST	
130	7.303-108.0	Screw 5x20 -10.9-R2R (In6Rd)	9.000	ST	
140	5.035-499.0	Deflector roll	1.000	ST	
150	6.303-315.0	Screw 8 x 35	9.000	ST	
160	7.312-026.0	Washer 6 -A2 ISO 7089	8.000	ST	
170	9.763-194.0	Screw M6x20 -A2-70 Scotchgrip	8.000	ST	
180	7.304-395.0	Hexagonal head screw M8x16-8.8-A2E ISO	1.000	ST	
190	7.312-267.0	Washer 5-A2 ISO 7094	2.000	ST	
200	7.312-268.0	Washer 8 -A2 ISO 7094	1.000	ST	
210	9.763-046.0	Seal string cellular rubber turbine	1.000	ST	
220	9.763-325.0	Rubber cover ball valve	1.000	ST	VERSION 2
220	9.763-054.0	Rubber stopper ball valve	1.000	ST	VERSION 1
300	9.753-054.0	Pad disk complete D51	1.000	ST	
310	6.371-146.0	Polishing pad beige 500 mm	1.000	ST	
310	6.371-320.0	Polishing pad white D508	1.000	ST	
310	6.369-468.0	Polishing pad beige	1.000	ZSA	
310	6.369-079.0	Pad red	1.000	ZSA	
310	6.369-078.0	Pad green	1.000	ZSA	

## 100 Brush-head B50 CS

---

<b>POS</b>	<b>Article no.</b>	<b>Description</b>	<b>Quantity</b>	<b>Unit</b>	<b>Foot note text</b>
310	6.369-077.0	Pad black	1.000	ZSA	
320	5.122-016.0	Centerlock reworking	1.000	ST	

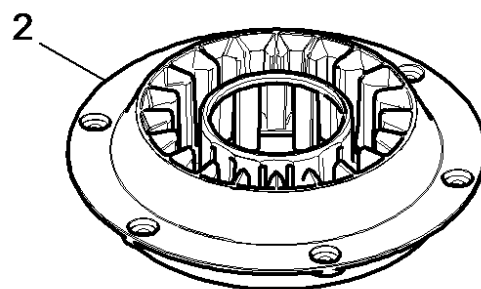

40 Disc brush complete nature D51 (4.905-027.0)

---

POS	Article no.	Description	Quantity	Unit
2	5.033-002.0	Retainer brush SWS	1.000	ST

---

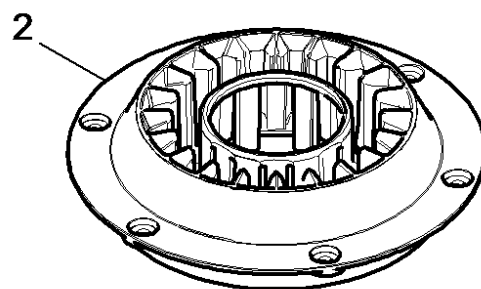

40 Disc brush complete white D51 (4.905-028.0)

---

<b>POS</b>	<b>Article no.</b>	<b>Description</b>	<b>Quantity</b>	<b>Unit</b>
2	5.033-002.0	Retainer brush SWS	1.000	ST

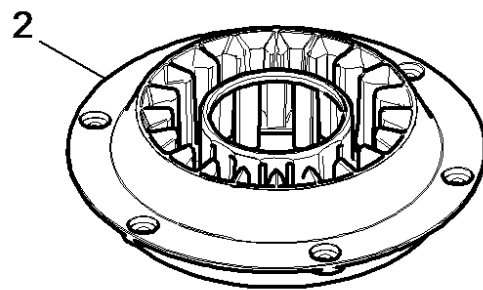



40 Disc brush complete black D51 (4.905-029.0)

---

<b>POS</b>	<b>Article no.</b>	<b>Description</b>	<b>Quantity</b>	<b>Unit</b>
2	5.033-002.0	Retainer brush SWS	1.000	ST

40 Disc brush complete red D51 (9.753-021.0)

---

<b>POS</b>	<b>Article no.</b>	<b>Description</b>	<b>Quantity</b>	<b>Unit</b>
2	5.033-002.0	Retainer brush SWS	1.000	ST

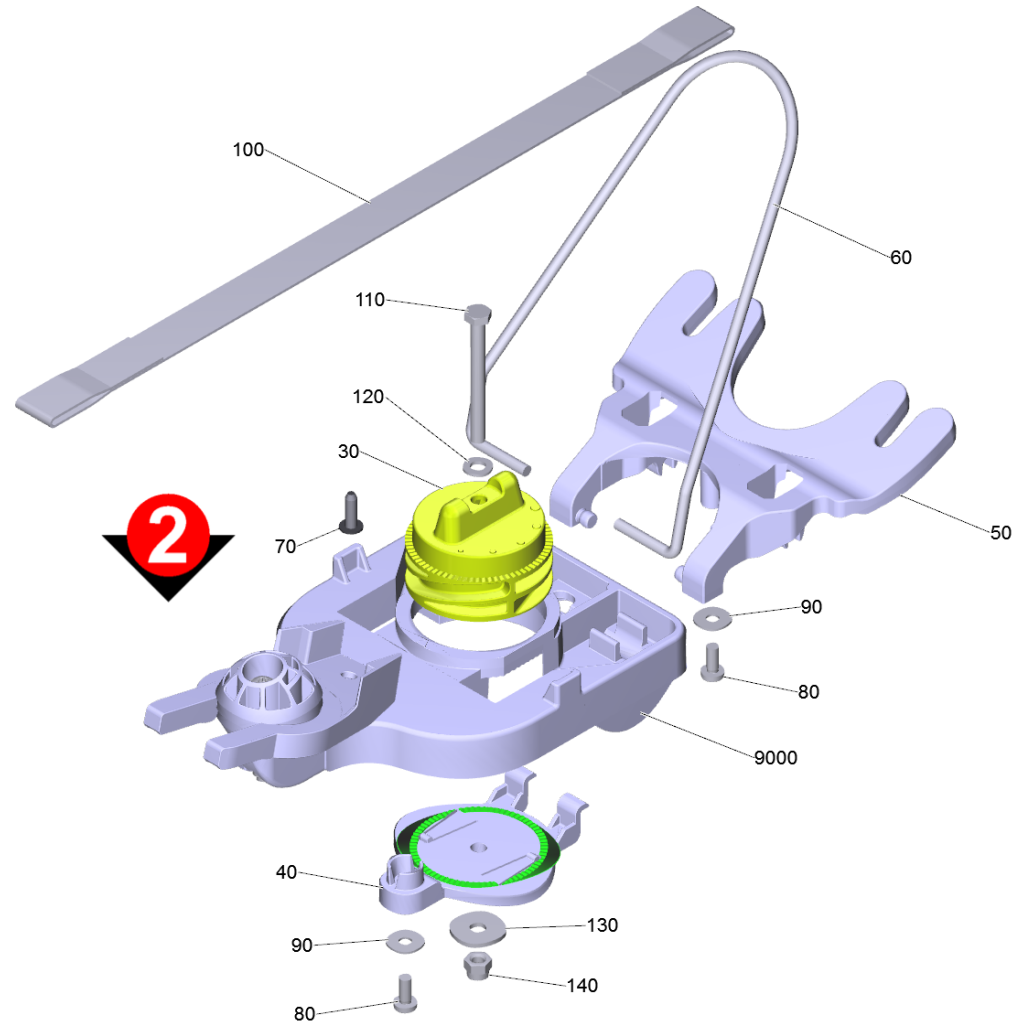
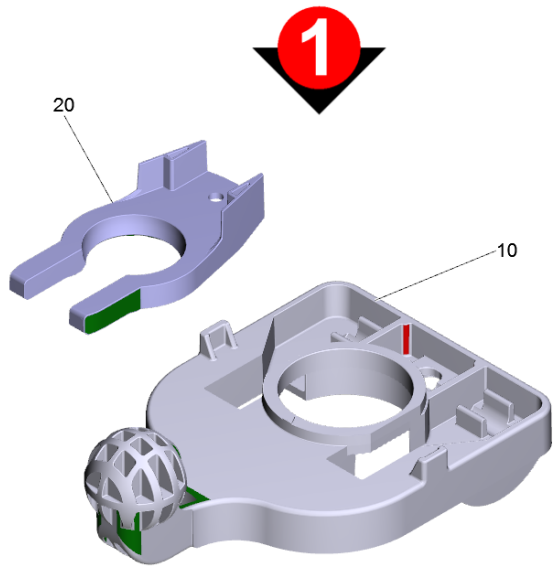

110 Suction bar lifting cpl. fix (9.753-213.0)

POS	Article no.	Description	Quantity	Unit	Foot note text
10	5.035-354.0	Holder suction bar	1.000	ST	VERSION 1
20	5.034-141.0	Fixing plate suction bar	1.000	ST	VERSION 1
30	5.035-292.0	Adjusting knob suction bar toothing	1.000	ST	
40	5.035-293.0	Covering cap suction bar toothing	1.000	ST	
50	5.036-103.0	Rocker suction bar	1.000	ST	
60	9.763-049.0	Retaining bracket suction beam retractio	1.000	ST	
70	7.303-107.0	Screw 5x16 -10.9-P2R (K-In6Rd)	1.000	ST	
80	6.306-003.0	Screw M5X12-A2/70-ISO 7045 (IN6RD)	2.000	ST	
90	7.312-282.0	Washer 5 -A2 ISO 7093-1	2.000	ST	
100	9.763-055.0	Strap suction bar	1.000	ST	
110	7.304-270.0	Screw M6x60 -8.8-ZFSL ISO 4014	1.000	ST	
120	7.312-003.0	Washer 6 -200HV-A3E ISO 7089	1.000	ST	
130	7.312-260.0	Washer 6 -100HV-A3E ISO 7094	1.000	ST	
140	7.311-512.0	Hexagon nut M 6-8-A2E ISO 7040	1.000	ST	
9000		Holder suction bar complete	1.000	ST	VERSION 2

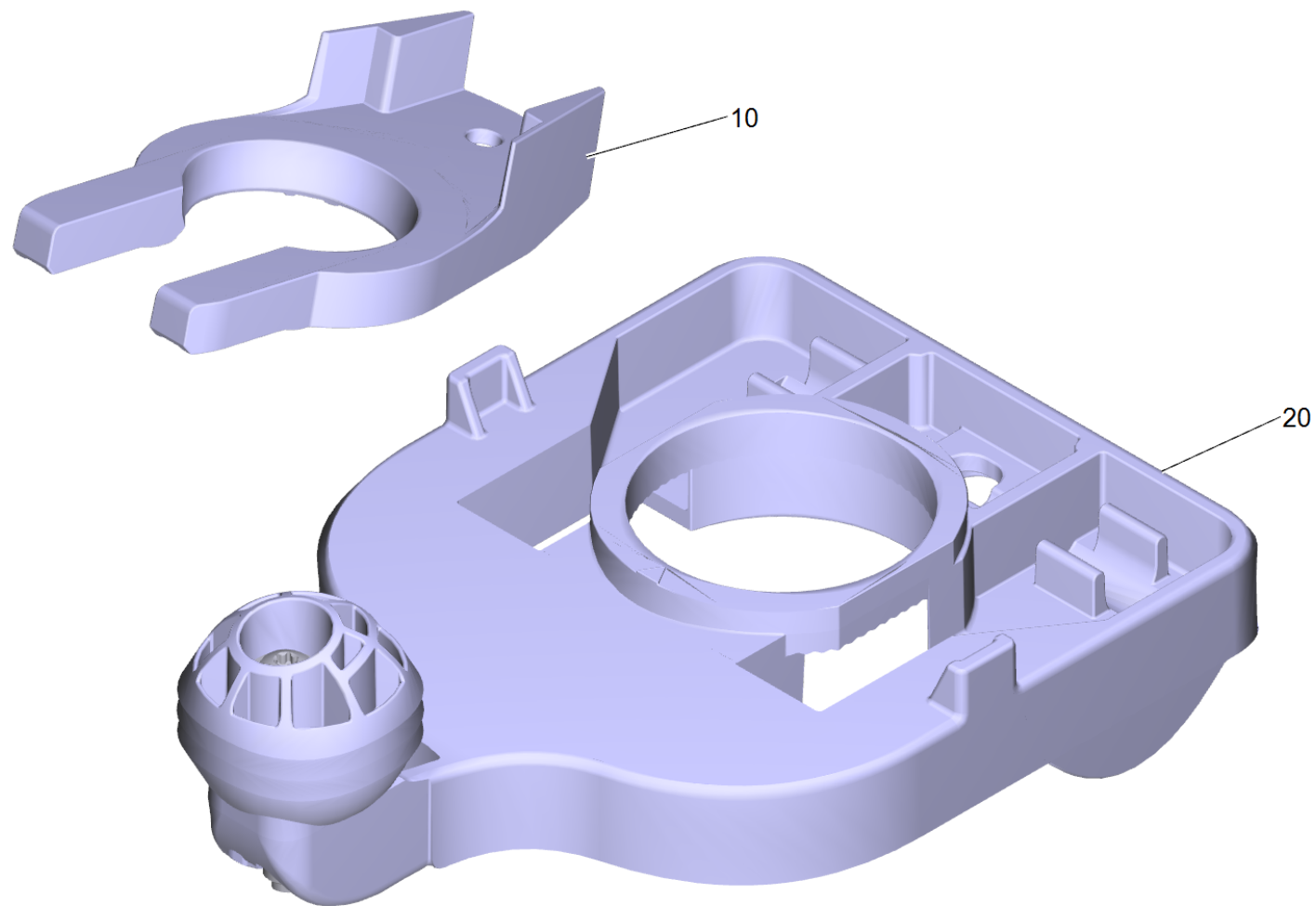

9000 Holder suction bar complete

---

<b>POS</b>	<b>Article no.</b>	<b>Description</b>	<b>Quantity</b>	<b>Unit</b>
10	5.005-005.0	FIXING PLATE SUCTION BAR ALU	1.000	ST
20	4.037-137.3	Holder suction bar	1.000	ST

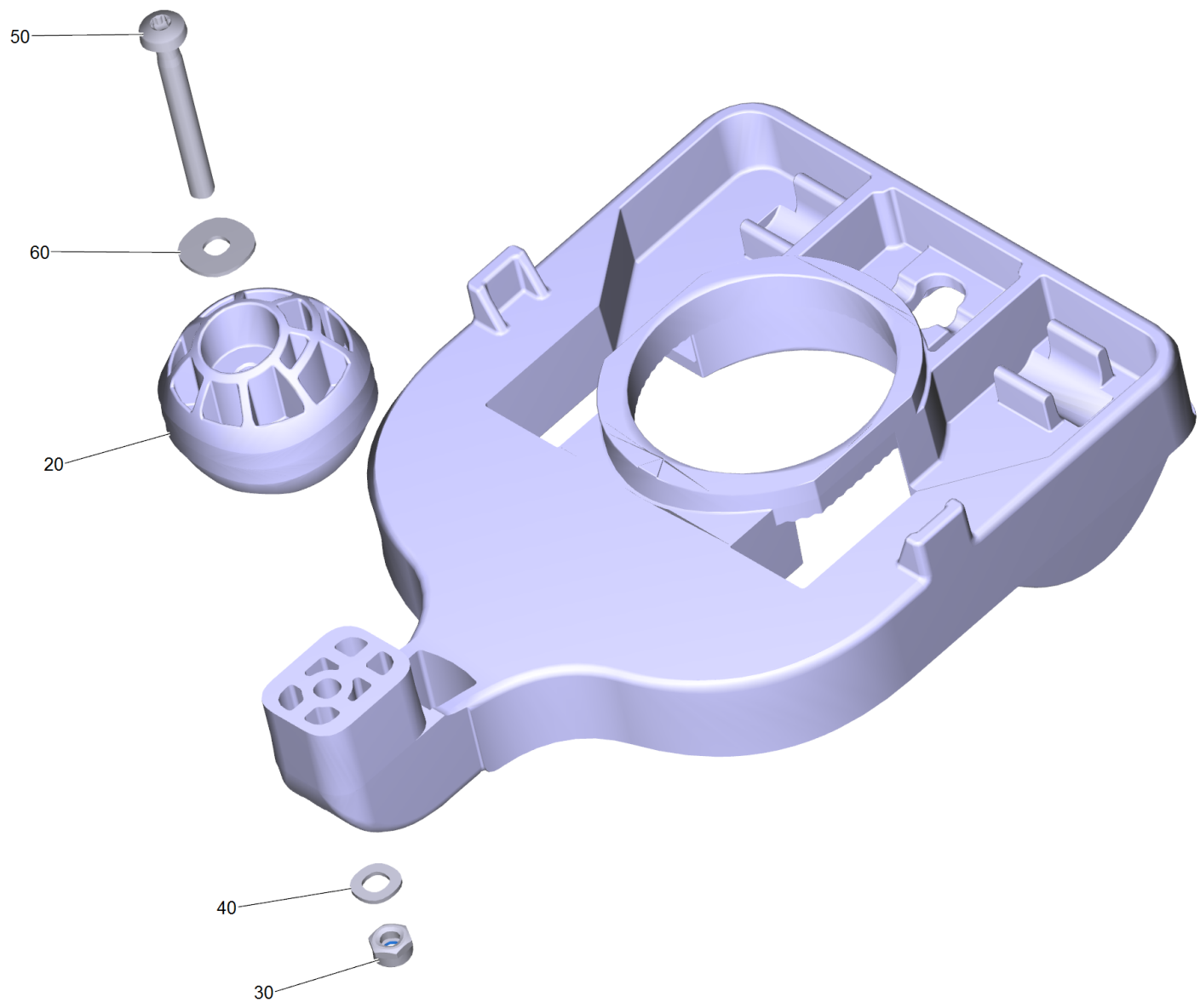

## 20 Holder suction bar (4.037-137.3)

---

<b>POS</b>	<b>Article no.</b>	<b>Description</b>	<b>Quantity</b>	<b>Unit</b>
20	5.037-579.0	Sphere suction bar suspension	1.000	ST
30	7.311-431.0	Hexagon nut M 5-1.4305 DIN 985	1.000	ST
40	7.312-052.0	Washer 5 -A2 ISO 7089	1.000	ST
50	7.306-215.0	Screw M5x45 -8.8-R2R (In6Rd)	1.000	ST
60	7.312-282.0	Washer 5 -A2 ISO 7093-1	1.000	ST



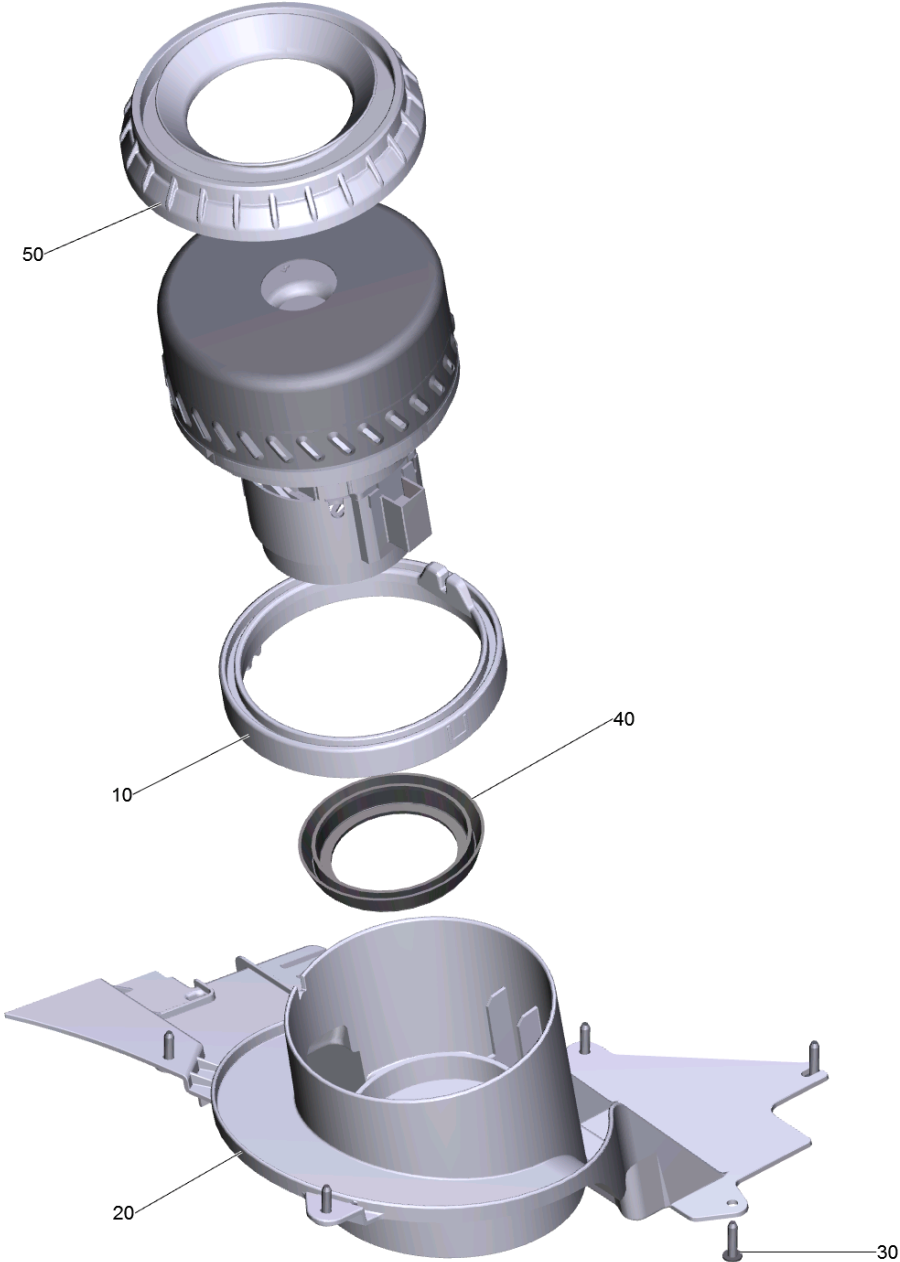

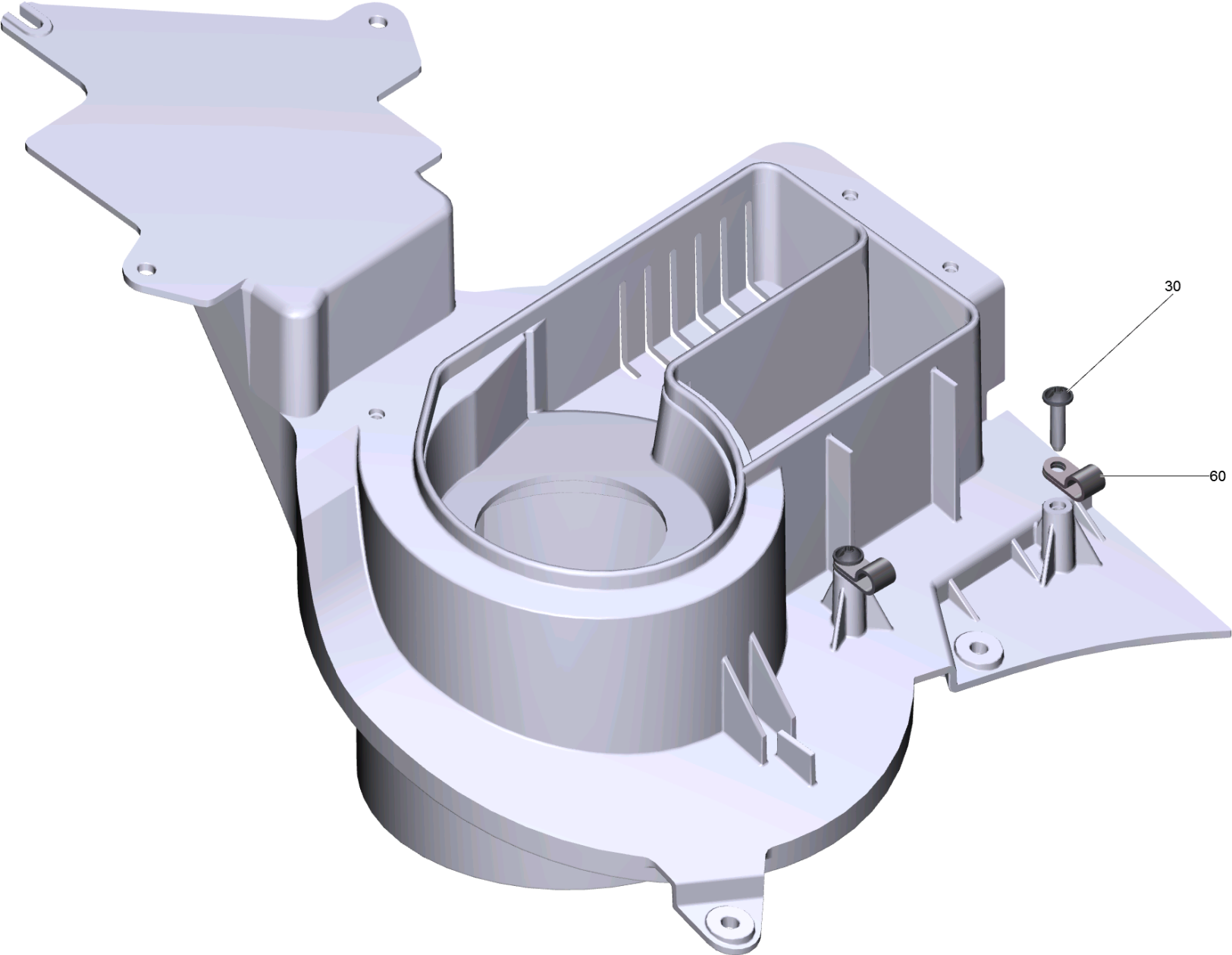

## 120 Retainer turbine complete B50 CS (9.753-004.0)

---

<b>POS</b>	<b>Article no.</b>	<b>Description</b>	<b>Quantity</b>	<b>Unit</b>
10	9.763-188.0	Joint ring turbine	1.000	ST
20	9.763-018.0	Air circulation turbine	1.000	ST
30	7.303-108.0	Screw 5x20 -10.9-R2R (In6Rd)	7.000	ST
40	5.363-395.0	Seal	1.000	ST
50	5.035-333.0	Bearing vacuum motor	1.000	ST
60	9.763-126.0	Cable clamp D9,5	2.000	ST

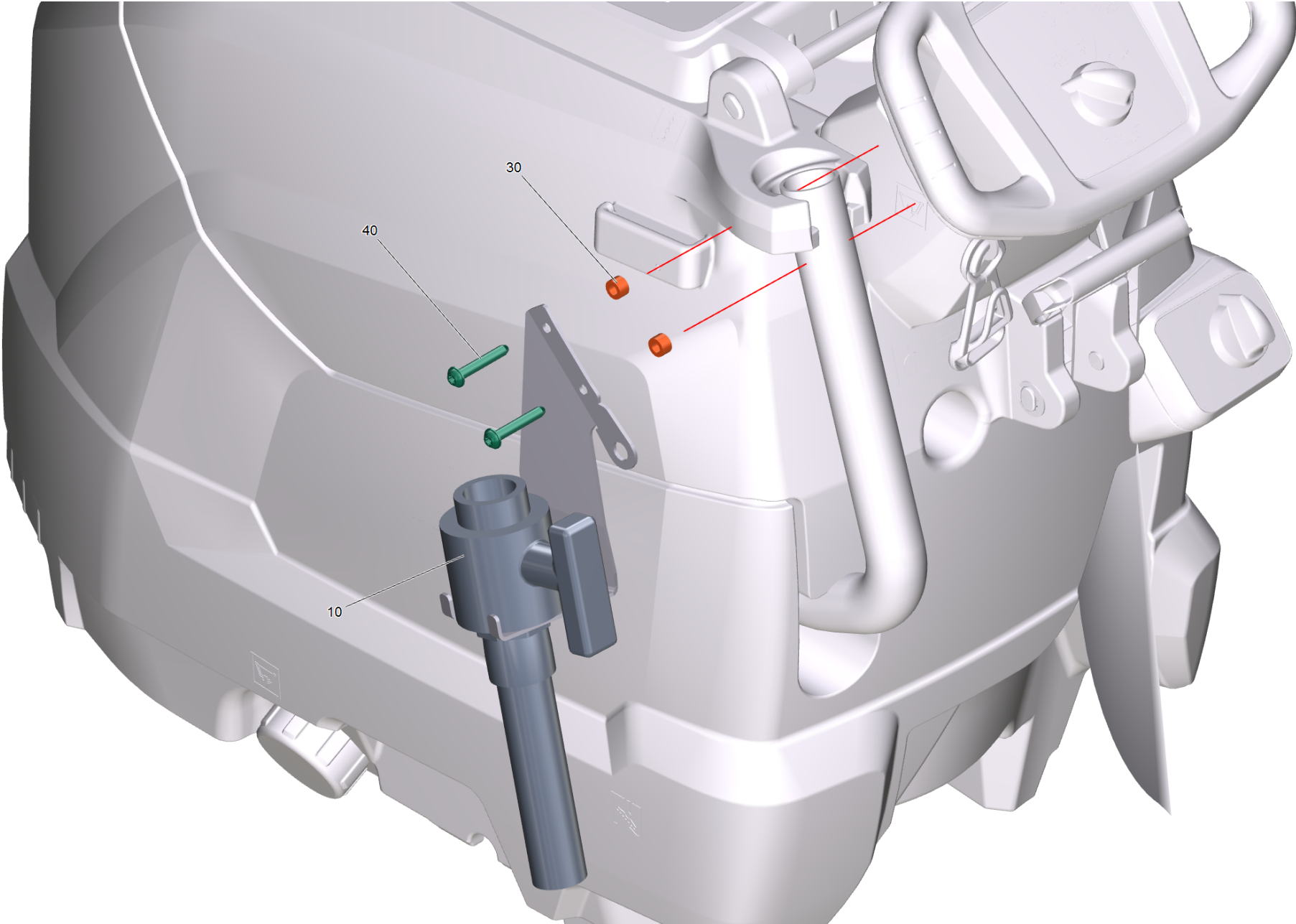

180 Add-on kit drain hose ball valve BD 50 (2.643-986.0)

---

<b>POS</b>	<b>Article no.</b>	<b>Description</b>	<b>Quantity</b>	<b>Unit</b>
10	9.753-072.0	Drain hose with ball valve	1.000	ST
20	5.036-216.0	Blank holder add-on kit drain hose BD 50	1.000	ST
30	5.095-901.0	spacer	2.000	ST
40	7.303-275.0	Screw 8x50 -10.9-A3E (In6Rd)	2.000	ST

9000 Suction bar straight 850mm (4.777-401.0)

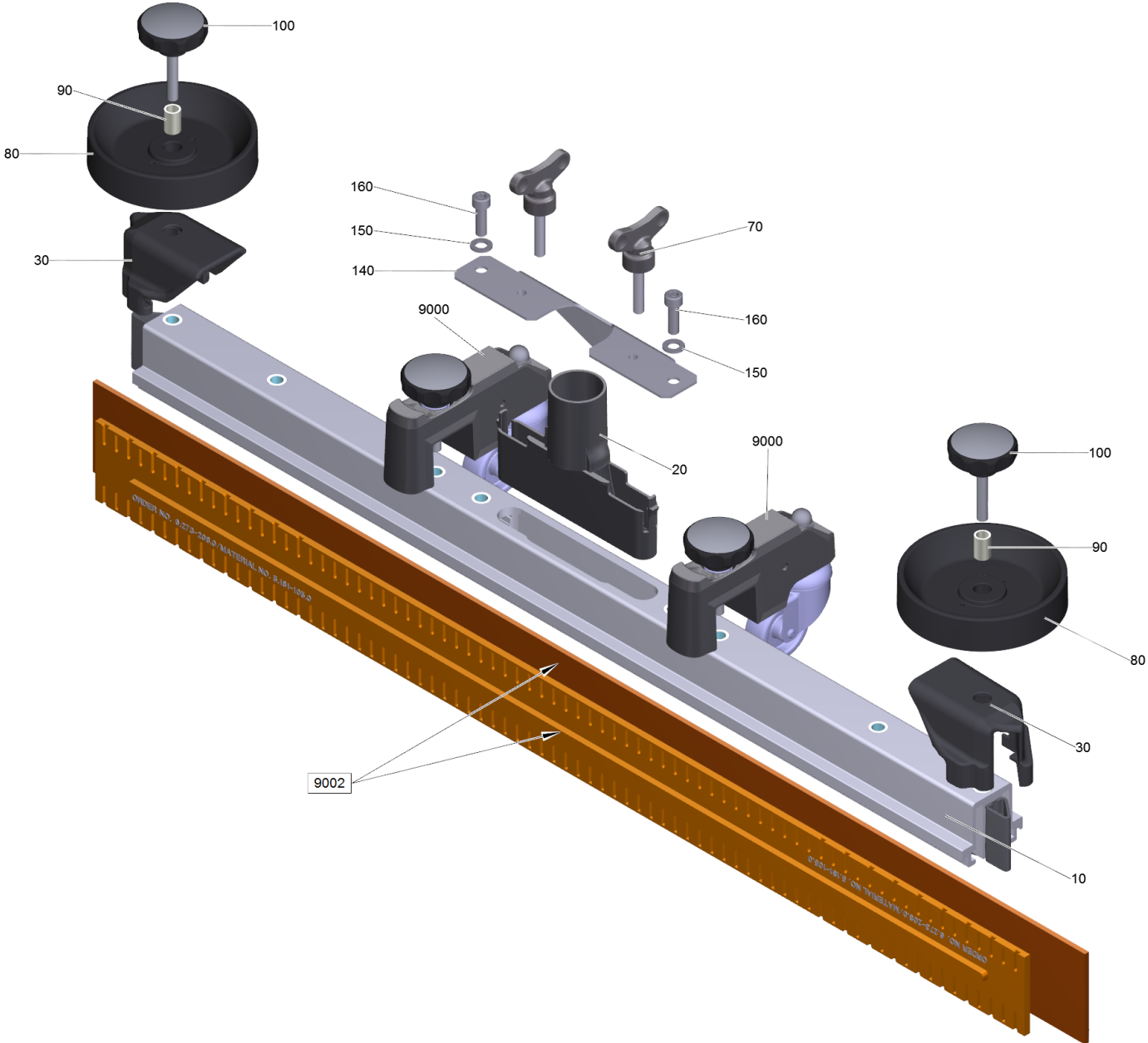

9000 Suction bar straight 850mm (4.777-401.0)

POS	Article no.	Description	Quantity	Unit	Remark	Foot note text
10	4.035-301.0	Suction bar pre-assembled straight 850mm	1.000	ST		
20	5.033-601.0	Suction nipple	1.000	ST		
30	2.885-294.0	End piece left / right spare parts set	1.000	ST		
70	5.305-008.0	Wing screw M8x30 VA	2.000	ST		
80	5.515-346.0	Deflector roll suction bar D120	2.000	ST		
90	5.094-231.0	Sleeve suction bar in VA	2.000	ST		
100	6.321-243.0	Star grip stainless steel D50x48	2.000	ST		
140	5.100-559.0	Suction bar support plate	1.000	ST		
150	7.312-017.0	Washer 8-A2 ISO 7089	2.000	ST		
160	7.306-142.0	Cylinder head screw M 8x25-A4-70 ISO 47	2.000	ST		
9000	4.035-339.0	Roller suction bar	2.000	ST	VERSION 1	
9000	4.035-281.0	Conversion kit support roller deep	2.000	ST	VERSION 2	ORDER QTY. 2
9002	6.273-290.0	BLADES FOR TEXTURED FLOORS	1.000	ST		
9002	6.273-229.0	Rubber lip set anti stripe oil resistant	1.000	ST		
9002	6.273-213.0	Rubber lip set standard	1.000	ZSA		STANDARD
9002	6.273-207.0	Rubber lip set oil resistant BR-BD530,55	1.000	ZSA		

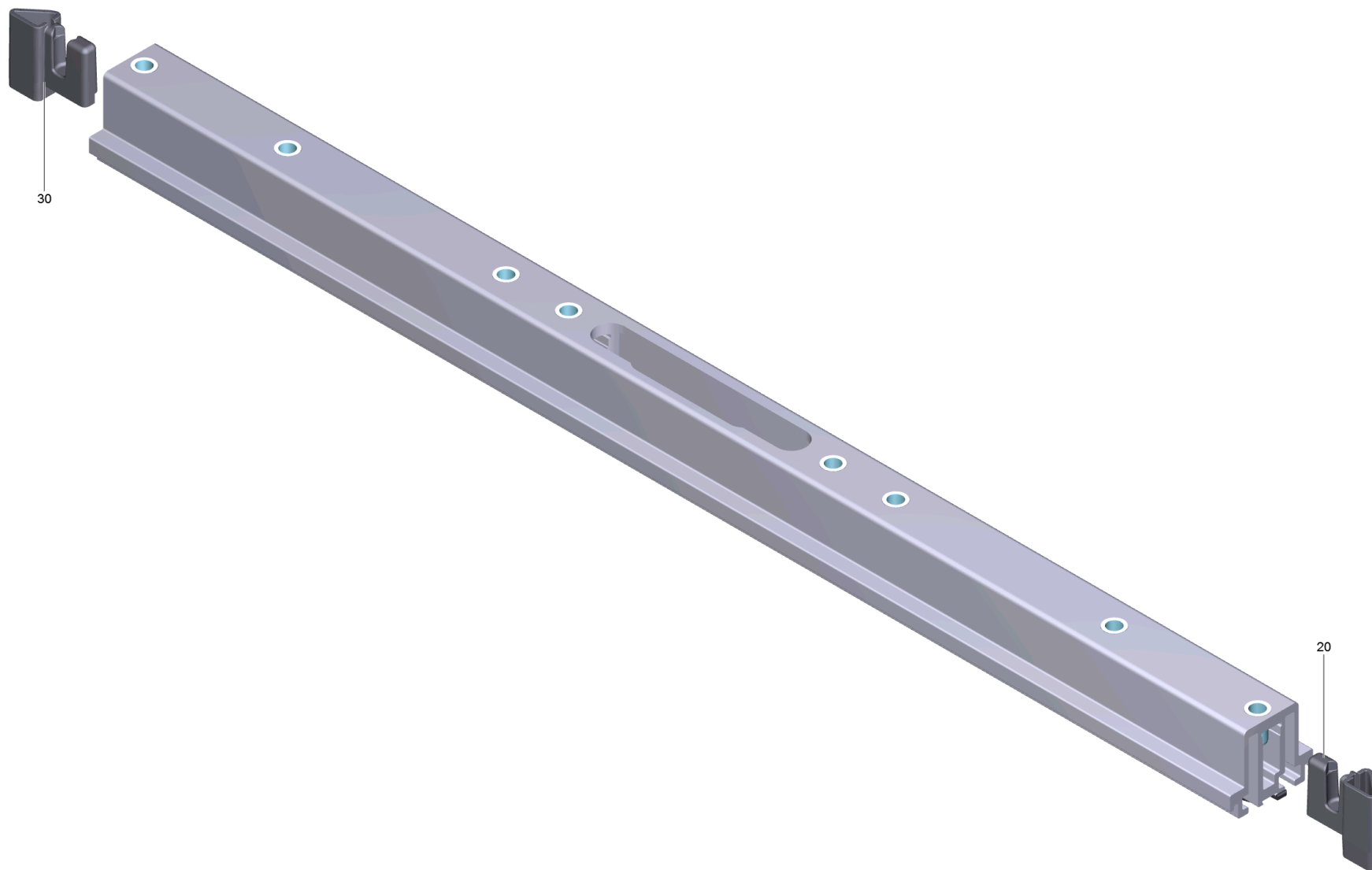



10 Suction bar pre-assembled straight 850mm (4.035-301.0)

---

<b>POS</b>	<b>Article no.</b>	<b>Description</b>	<b>Quantity</b>	<b>Unit</b>
20	5.033-578.0	End piece inside left	1.000	ST
30	5.033-579.0	End piece inside right	1.000	ST

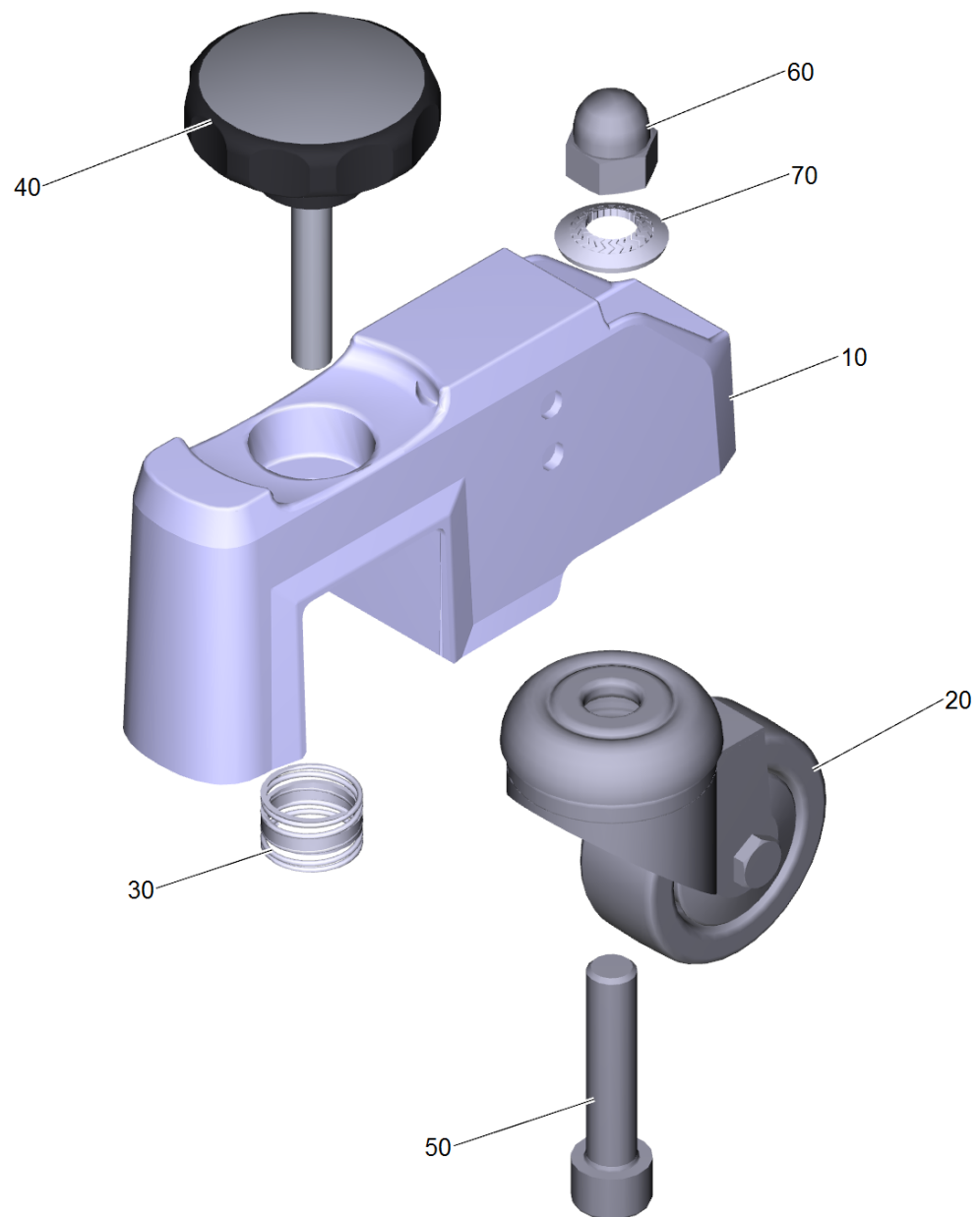

## 9000 Conversion kit support roller deep (4.035-281.0)

---

<b>POS</b>	<b>Article no.</b>	<b>Description</b>	<b>Quantity</b>	<b>Unit</b>
10	5.101-626.0	Housing with additional weight	1.000	ST
20	6.435-179.0	Castor for thread deflector	1.000	ST
30	5.332-554.0	Pressure spring	1.000	ST
40	6.321-240.0	Star grip with inscription VA Ø50x43	1.000	ST
50	7.306-068.0	Cylinder head screw M10x45-8.8-A2K DIN 912	1.000	ST
60	7.311-382.0	Cap nut M10-6-A3E DIN 1587	1.000	ST
70	6.996-526.0	Serrated locking washer d.10	1.000	ST

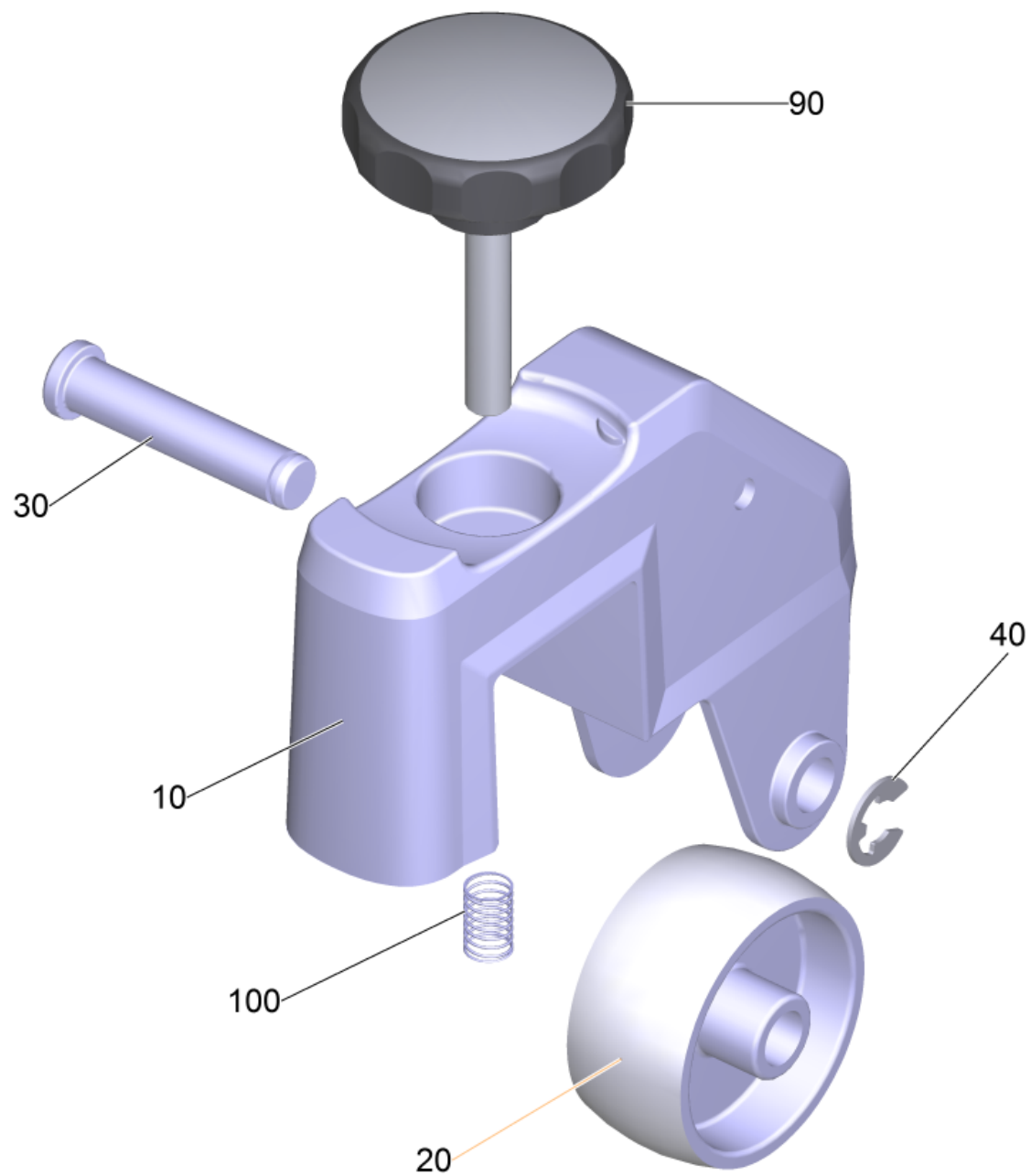

## 9000 Roller suction bar (4.035-339.0)

---

<b>POS</b>	<b>Article no.</b>	<b>Description</b>	<b>Quantity</b>	<b>Unit</b>
10	5.101-139.0	Roller holder weight	1.000	ST
20	6.435-401.0	Wheel D54	1.000	ST
30	5.317-781.0	Bolt roller	1.000	ST
40	7.343-303.0	Locking ring 8-A2 DIN 6799	1.000	ST
90	6.321-240.0	Star grip with inscription VA Ø50x43	1.000	ST
100	5.332-504.0	Pressure spring	1.000	ST

9002 BLADES FOR TEXTURED FLOORS (6.273-290.0)

---

POS	Article no.	Description	Quantity	Unit
20	6.273-229.0	Rubber lip set anti stripe oil resistant	1.000	ST

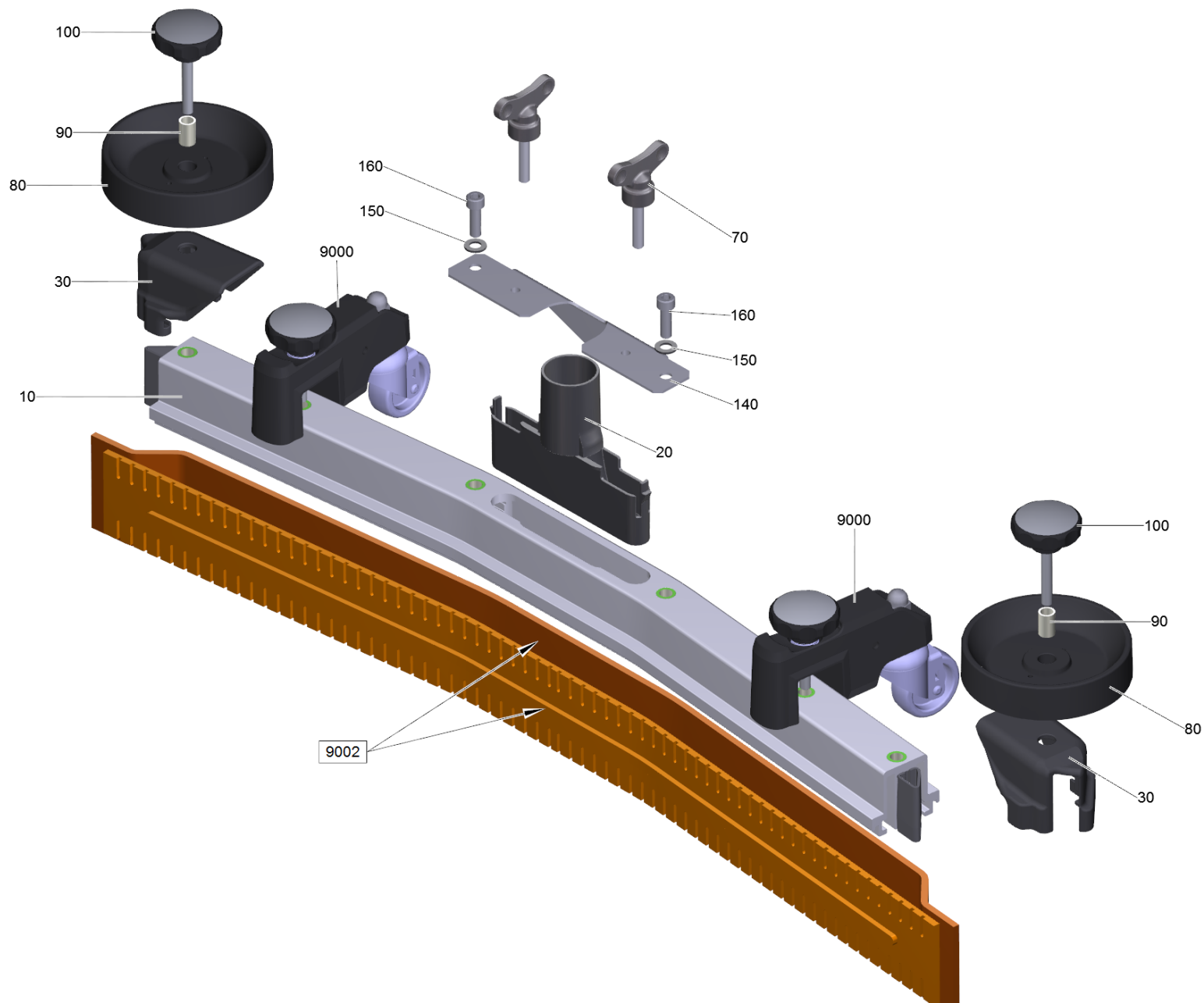

9000 Suction bar curved 850mm (4.777-411.0)

POS	Article no.	Description	Quantity	Unit	Remark	Foot note text
10	4.035-311.0	Suction bar pre-assembled curved 850mm	1.000	ST		
20	5.033-601.0	Suction nipple	1.000	ST		
30	2.885-294.0	End piece left / right spare parts set	1.000	ST		
70	5.305-008.0	Wing screw M8x30 VA	2.000	ST		
80	5.515-346.0	Deflector roll suction bar D120	2.000	ST		
90	5.094-231.0	Sleeve suction bar in VA	2.000	ST		
100	6.321-243.0	Star grip stainless steel D50x48	2.000	ST		
140	5.100-559.0	Suction bar support plate	1.000	ST		
150	7.312-017.0	Washer 8-A2 ISO 7089	2.000	ST		
160	7.306-142.0	Cylinder head screw M 8x25-A4-70 ISO 47	2.000	ST		
9000	4.035-339.0	Roller suction bar	2.000	ST	VERSION 1	
9000	4.035-281.0	Conversion kit support roller deep	2.000	ST	VERSION 2	ORDER QTY. 2
9002	6.273-290.0	BLADES FOR TEXTURED FLOORS	1.000	ST		
9002	6.273-229.0	Rubber lip set anti stripe oil resistant	1.000	ST		
9002	6.273-213.0	Rubber lip set standard	1.000	ZSA		STANDARD
9002	6.273-207.0	Rubber lip set oil resistant BR-BD530,55	1.000	ZSA		



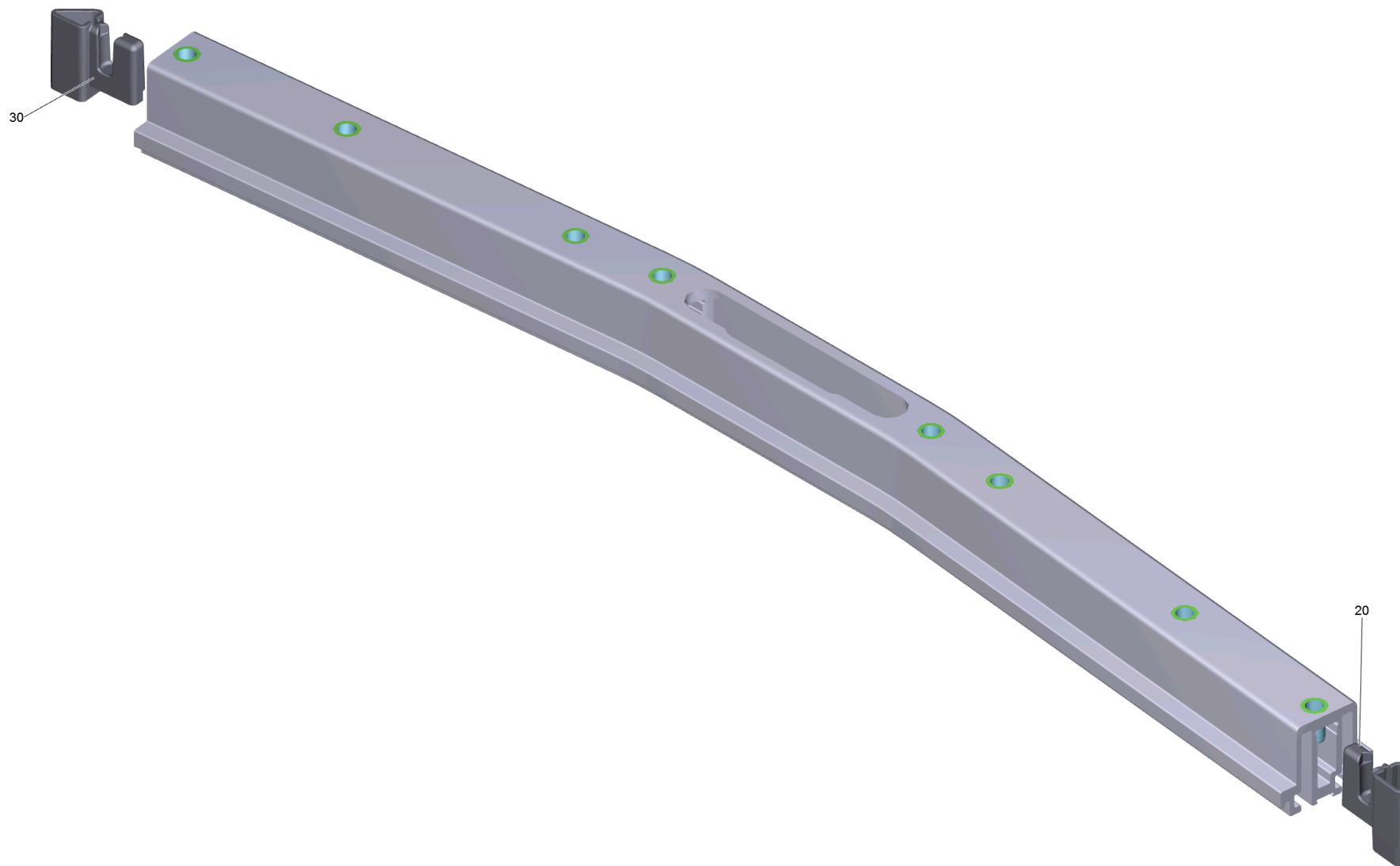

10 Suction bar pre-assembled curved 850mm (4.035-311.0)

---

<b>POS</b>	<b>Article no.</b>	<b>Description</b>	<b>Quantity</b>	<b>Unit</b>
20	5.033-578.0	End piece inside left	1.000	ST
30	5.033-579.0	End piece inside right	1.000	ST

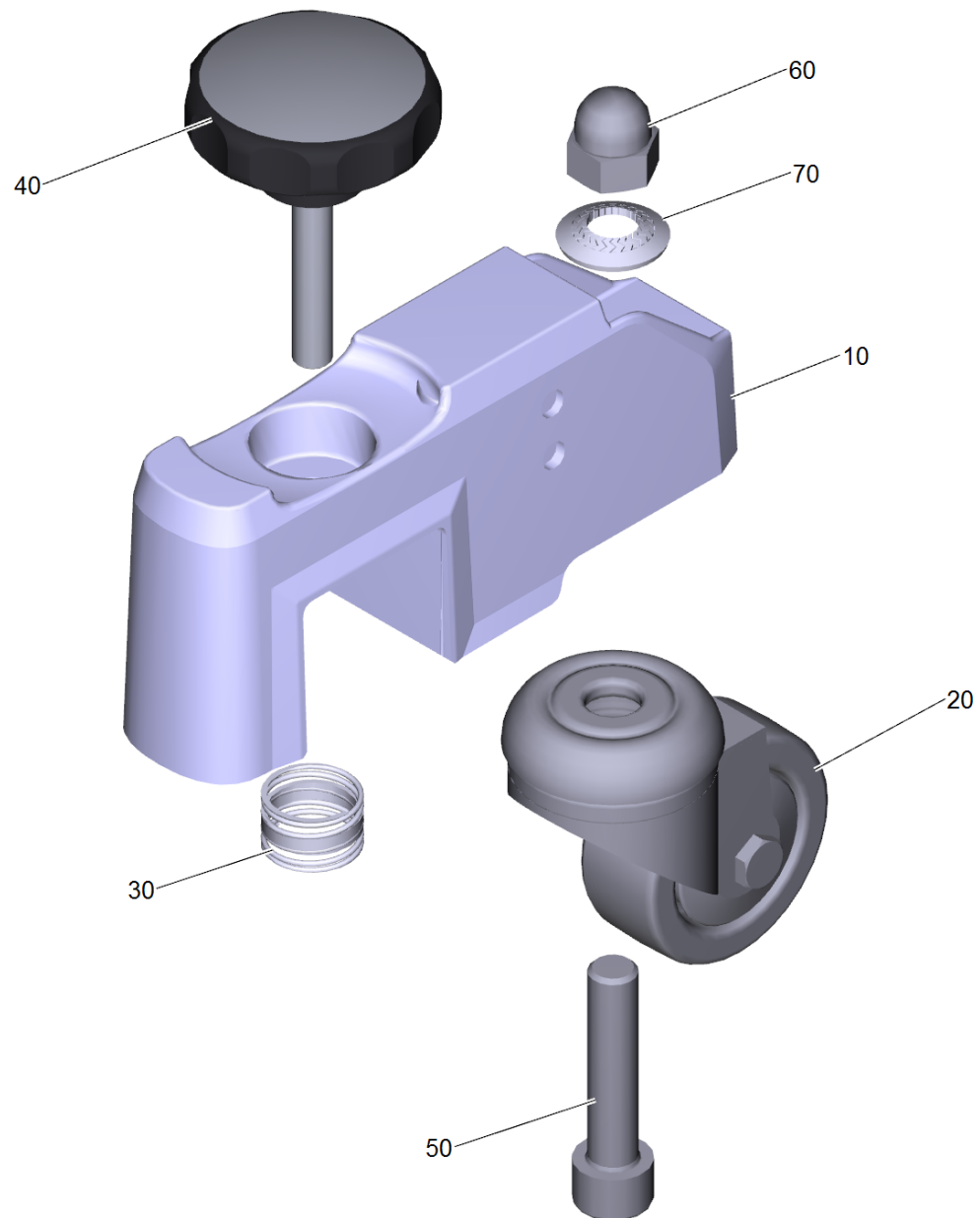

## 9000 Conversion kit support roller deep (4.035-281.0)

---

POS	Article no.	Description	Quantity	Unit
10	5.101-626.0	Housing with additional weight	1.000	ST
20	6.435-179.0	Castor for thread deflector	1.000	ST
30	5.332-554.0	Pressure spring	1.000	ST
40	6.321-240.0	Star grip with inscription VA Ø50x43	1.000	ST
50	7.306-068.0	Cylinder head screw M10x45-8.8-A2K DIN 912	1.000	ST
60	7.311-382.0	Cap nut M10-6-A3E DIN 1587	1.000	ST
70	6.996-526.0	Serrated locking washer d.10	1.000	ST

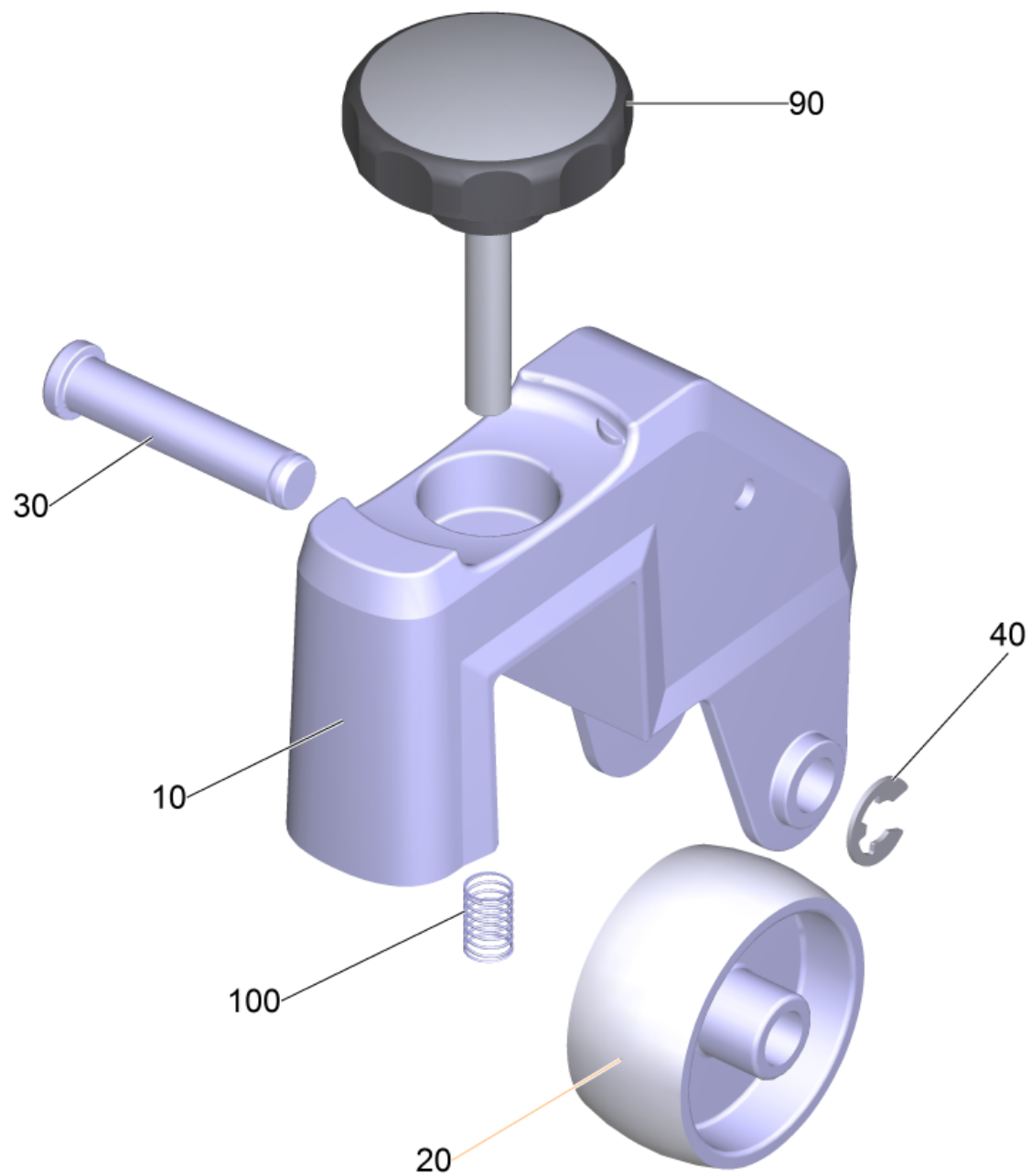

## 9000 Roller suction bar (4.035-339.0)

---

<b>POS</b>	<b>Article no.</b>	<b>Description</b>	<b>Quantity</b>	<b>Unit</b>
10	5.101-139.0	Roller holder weight	1.000	ST
20	6.435-401.0	Wheel D54	1.000	ST
30	5.317-781.0	Bolt roller	1.000	ST
40	7.343-303.0	Locking ring 8-A2 DIN 6799	1.000	ST
90	6.321-240.0	Star grip with inscription VA Ø50x43	1.000	ST
100	5.332-504.0	Pressure spring	1.000	ST

9002 BLADES FOR TEXTURED FLOORS (6.273-290.0)

---

<b>POS</b>	<b>Article no.</b>	<b>Description</b>	<b>Quantity</b>	<b>Unit</b>
20	6.273-229.0	Rubber lip set anti stripe oil resistant	1.000	ST

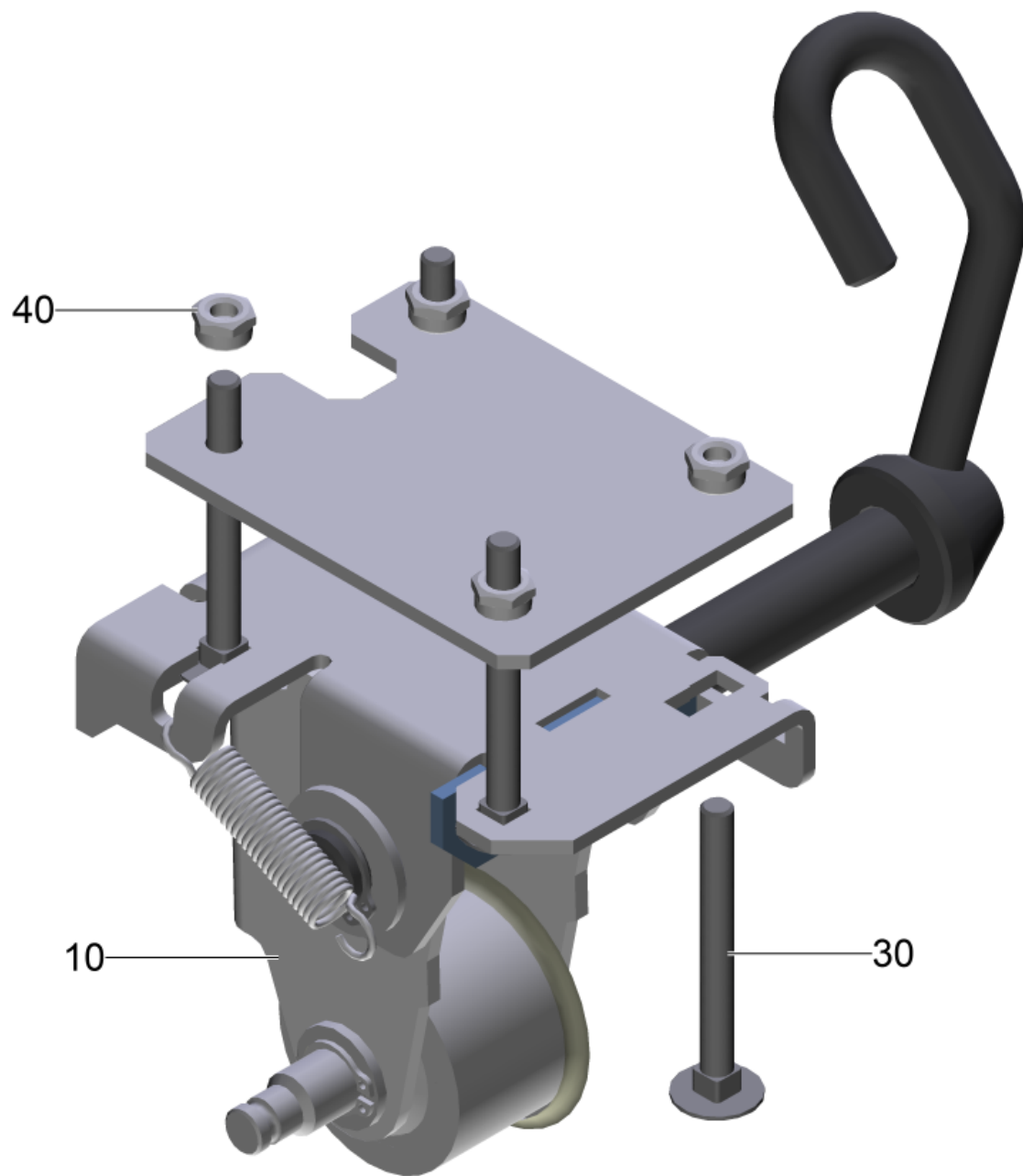



9001 Add-on kit carriage roller (2.643-723.0)

---

<b>POS</b>	<b>Article no.</b>	<b>Description</b>	<b>Quantity</b>	<b>Unit</b>
10	9.753-049.0	Roller complete	1.000	ST
30	7.303-233.0	Saucer-head screw M6x60 -St-A0P DIN 603	4.000	ST
40	7.311-425.0	Hexagon nut M6 -04-A2E DIN 985	4.000	ST

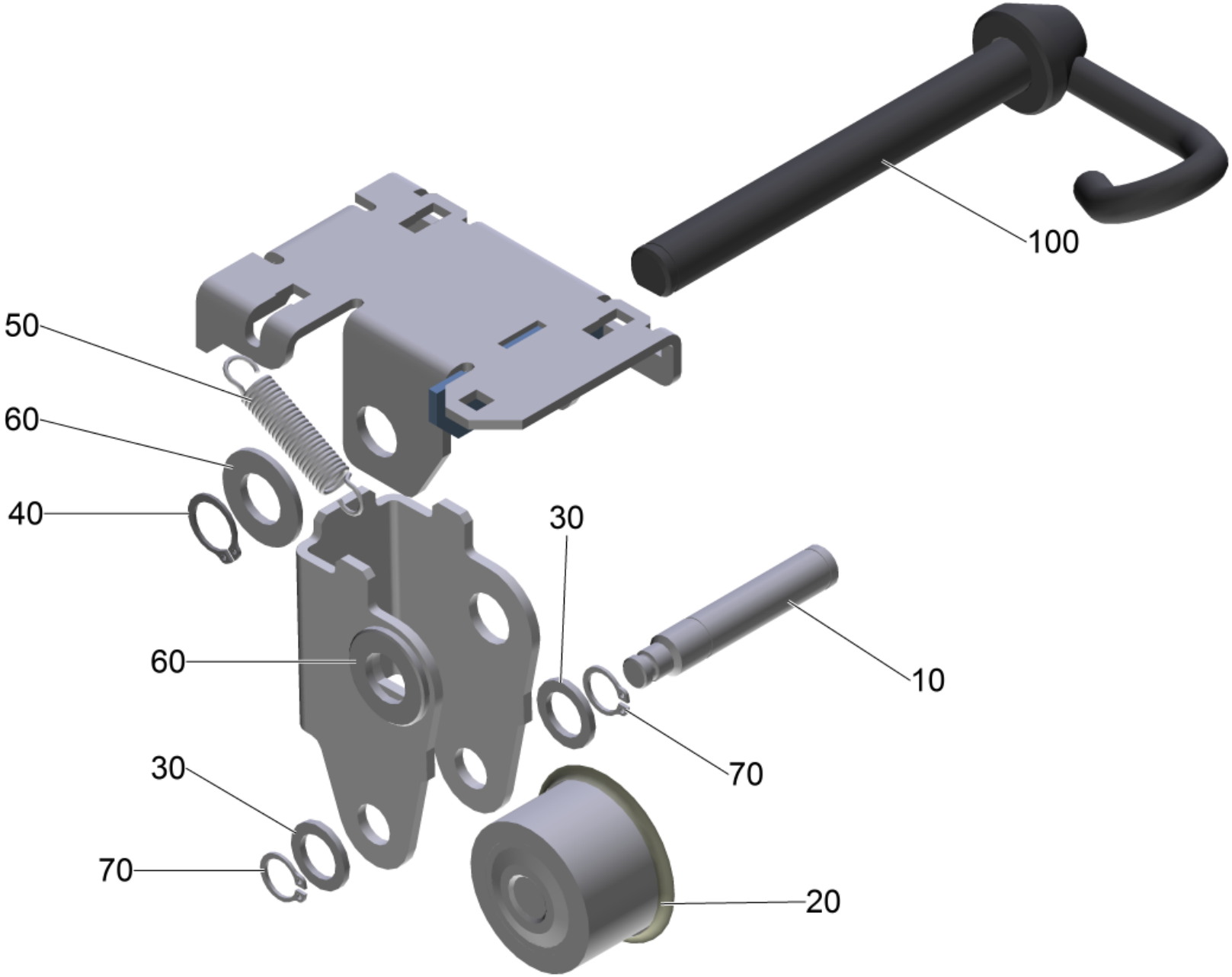

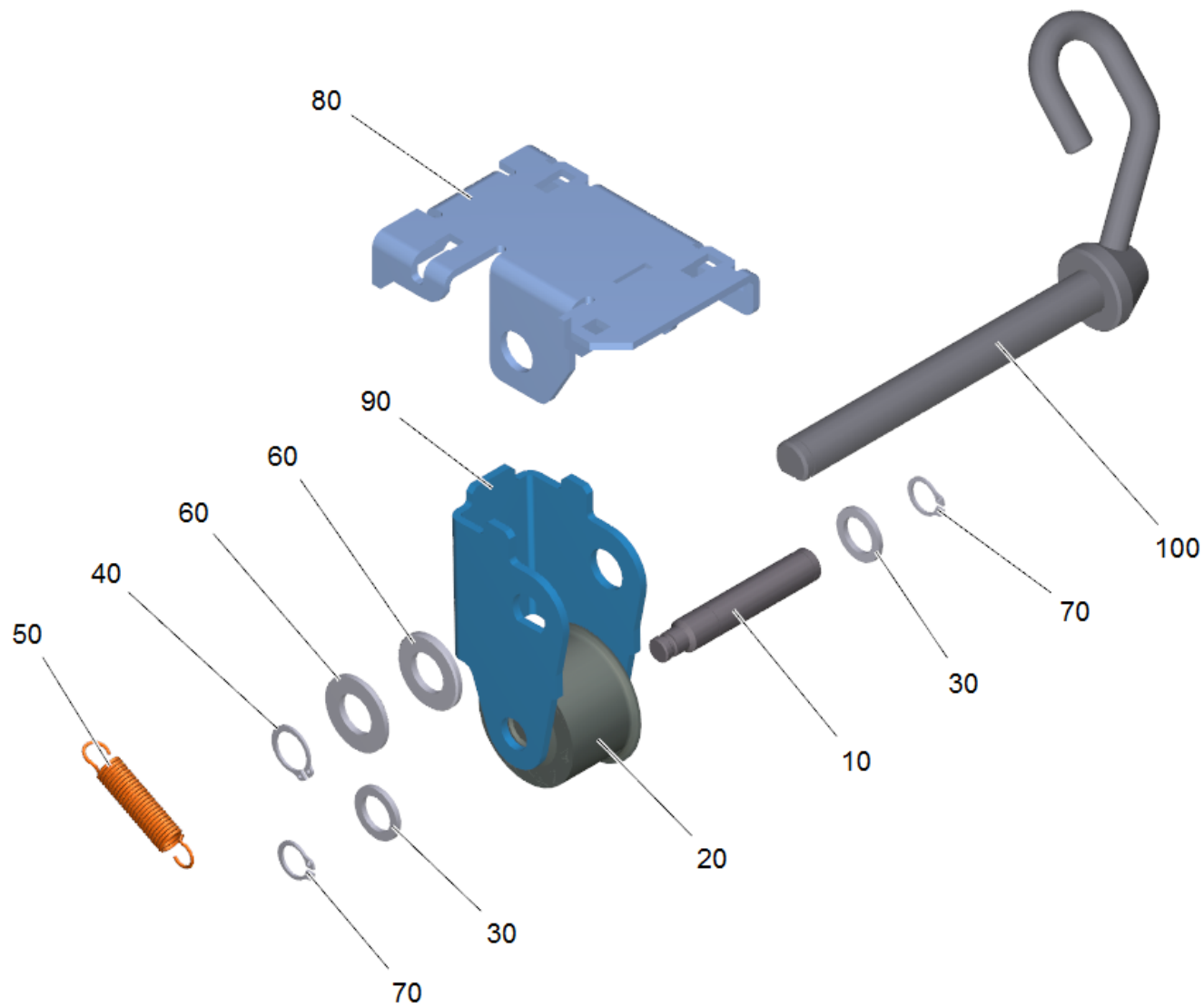

## 10 Roller complete (9.753-049.0)

---

<b>POS</b>	<b>Article no.</b>	<b>Description</b>	<b>Quantity</b>	<b>Unit</b>
10	9.763-212.0	Shaft roller	1.000	ST
20	9.763-053.0	Roller with ball bearing	1.000	ST
30	7.312-075.0	Washer 12-CuZn ISO 7092	2.000	ST
40	7.343-015.0	Locking ring 15x1-FST-RF DIN 471	1.000	ST
50	9.763-213.0	Extension spring	1.000	ST
60	7.312-028.0	Washer 14-200HV-A3E ISO7089	2.000	ST
70	7.343-083.0	Locking ring 12x1 -FSt DIN 471	2.000	ST
100	9.753-048.0	Pedal complete	1.000	ST

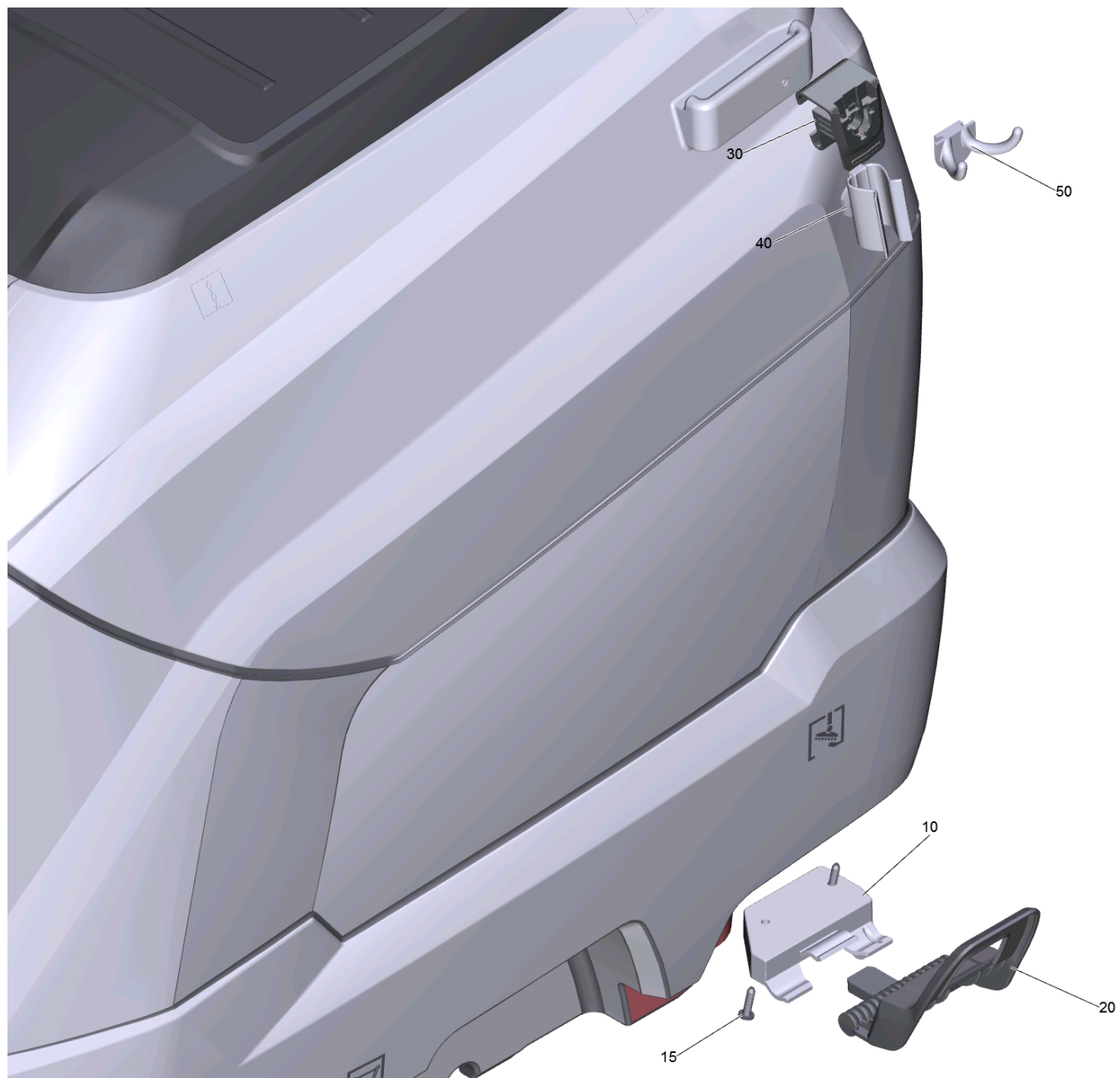

9500 Mop holder complete (9.753-023.0)

---

<b>POS</b>	<b>Article no.</b>	<b>Description</b>	<b>Quantity</b>	<b>Unit</b>
10	9.763-074.0	Fixing mop support	1.000	ST
15	7.303-109.0	Screw 5x25 -10.9-R2R (In6Rd)	3.000	ST
20	9.763-133.0	Support mop	1.000	ST
30	5.035-488.0	Adapter Homebase	2.000	ST
40	6.980-078.0	Holder handhold grey	1.000	ST
50	6.980-077.0	Double hook	1.000	ST

9532 Mounting kit battery kit (2.638-036.0)

---

<b>POS</b>	<b>Article no.</b>	<b>Description</b>	<b>Quantity</b>	<b>Unit</b>
10	6.649-879.0	Cable battery 25 mm <sup>2</sup> . 160 mm	1.000	ST
20	5.642-021.0	Distance holder battery	1.000	ST

9542 Mounting kit battery kit (2.638-144.0)

---

<b>POS</b>	<b>Article no.</b>	<b>Description</b>	<b>Quantity</b>	<b>Unit</b>
10	6.641-947.0	Cable battery BD 50 u 25 Hoppeke	1.000	ST
30	5.037-816.0	Distance holder battery BD50/50	1.000	ST