

Pos.	Mat-Nr.	Bezeichnung	Menge
Pos. 1	5.115-375.0	Scheibe (Kupfering)	4
Pos. 2	7.312-067.0	Scheibe 4-A2 ISO 70891	2
Pos. 3	7.303-062.0	Bl.Schr. ST3,5X 9,5-ST-A2R (IN6RD)	2
Pos. 4	7.312-026.0	Scheibe 6 -A2 ISO 7090	4
Pos. 5	7.306-193.0	Schraube M6x16 -A2-70 (In6Rd)	4

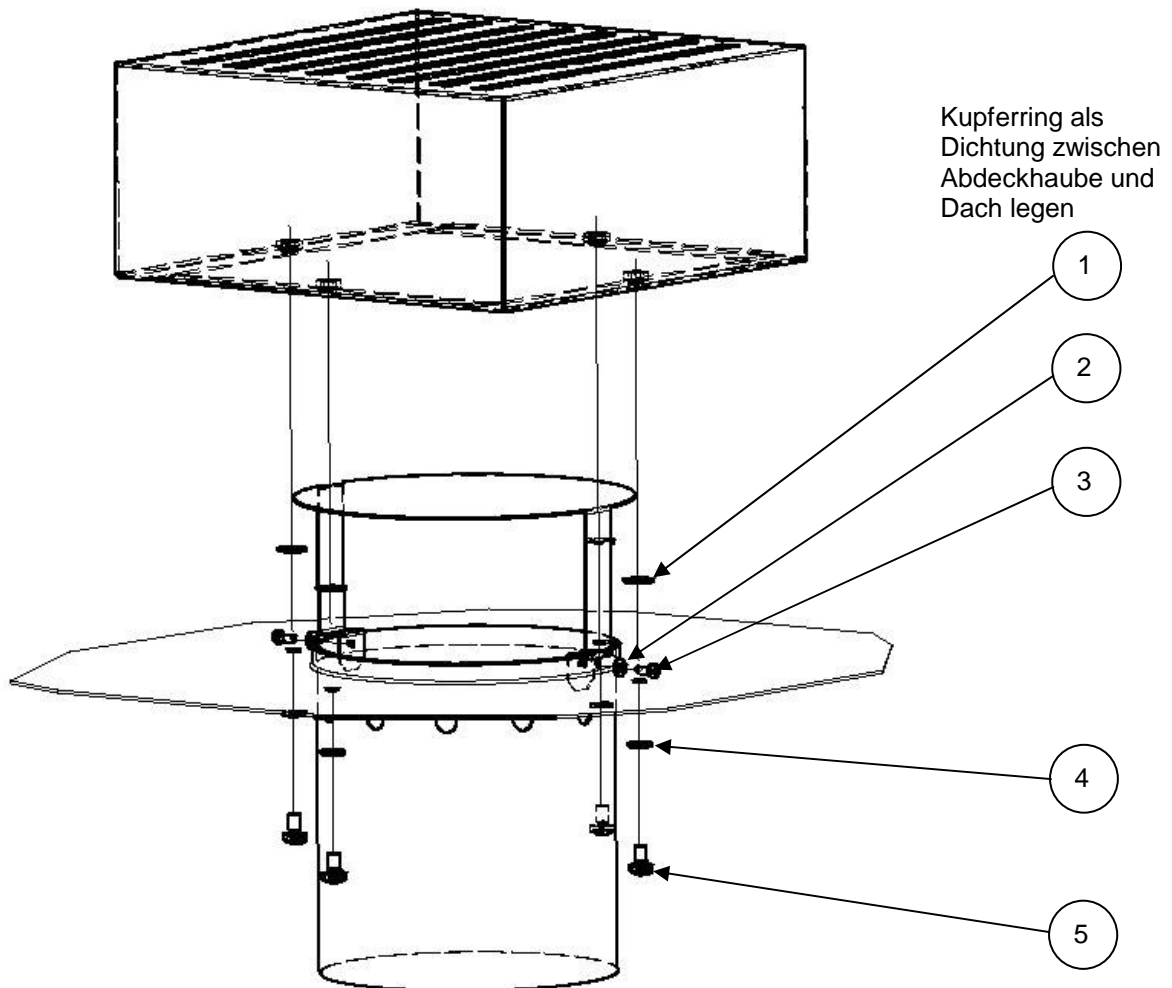

			Ersatz für <sup>a</sup>	Dokument	Nummer	Art	Teil. Dok.	Vers		Blatt	Biz
			22.06.05	MA Kamin	5077298	MTA	001	01		1	1
Datum	Gezeichnet	Geprüft	Normgeprüft	Änd. Ind.	Änd. Anz.	Freig./Änd-Nr.	Ersteller		Erstelldatum		
13.11.06	ILOWII	ILOKNAP	PED-S	a	1	2015193	ILOWII		22.06.05		
<p><b>Alfred Kärcher GmbH &amp; Co. KG Alfred Kärcher Str. 28 - 40 D-71364 Winnenden Tel. (07195) 14 - 0</b></p>											

Item	Mat No.	Description	Quantity
Item 1	5.115-375.0	Washer (copper ring)	4
Item 2	7.312-067.0	Washer 4-A2 ISO 70891	2
Item 3	7.303-062.0	Screw. ST3.5X 9.5-ST-A2R (IN6RD)	2
Item 4	7.312-026.0	Washer 6 -A2 ISO 7090	4
Item 5	7.306-193.0	Screw M6x16 -A2-70 (In6Rd)	4

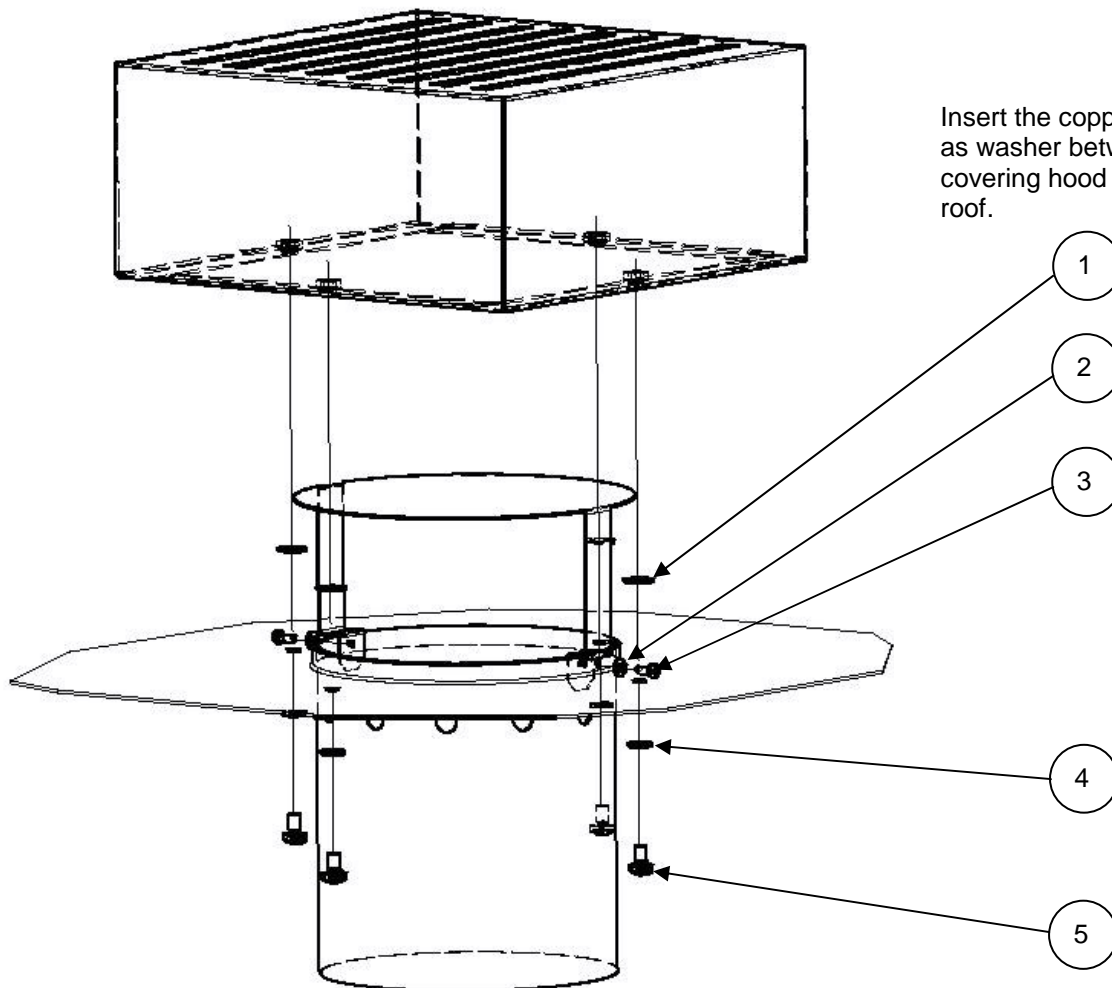

Insert the copper ring as washer between the covering hood and the roof.

			Replaces <sup>(a)</sup>	Document	Number	Type	Part. Doc.	Vers	Page	Of
			22.06.05	<b>MA Chimney</b>	<b>5077298</b>	<b>MTA</b>	<b>001</b>	<b>01</b>	<b>1</b>	<b>1</b>
Date	Signed	Checked	Std. Chkd	Ch g.	Nu m	Rel/Chng-No.	Author	Created on		
13.11.06	IL0WII	IL0KNAP	PED-S	a	1	2015193	IL0WII	22.06.05		
<p><b>Alfred Kärcher GmbH &amp; Co. KG Alfred Kärcher Str. 28 - 40 D-71364 Winnenden Tel. (07195) 14 - 0</b></p>										