

12 Handhold adjustment

Professional \ Floor cleaner \ Single disc machines \ BDS 43/180 C Adv *EU \ Spare parts list BDS 43+51/180 C \ Handhold \ Handhold adjustment

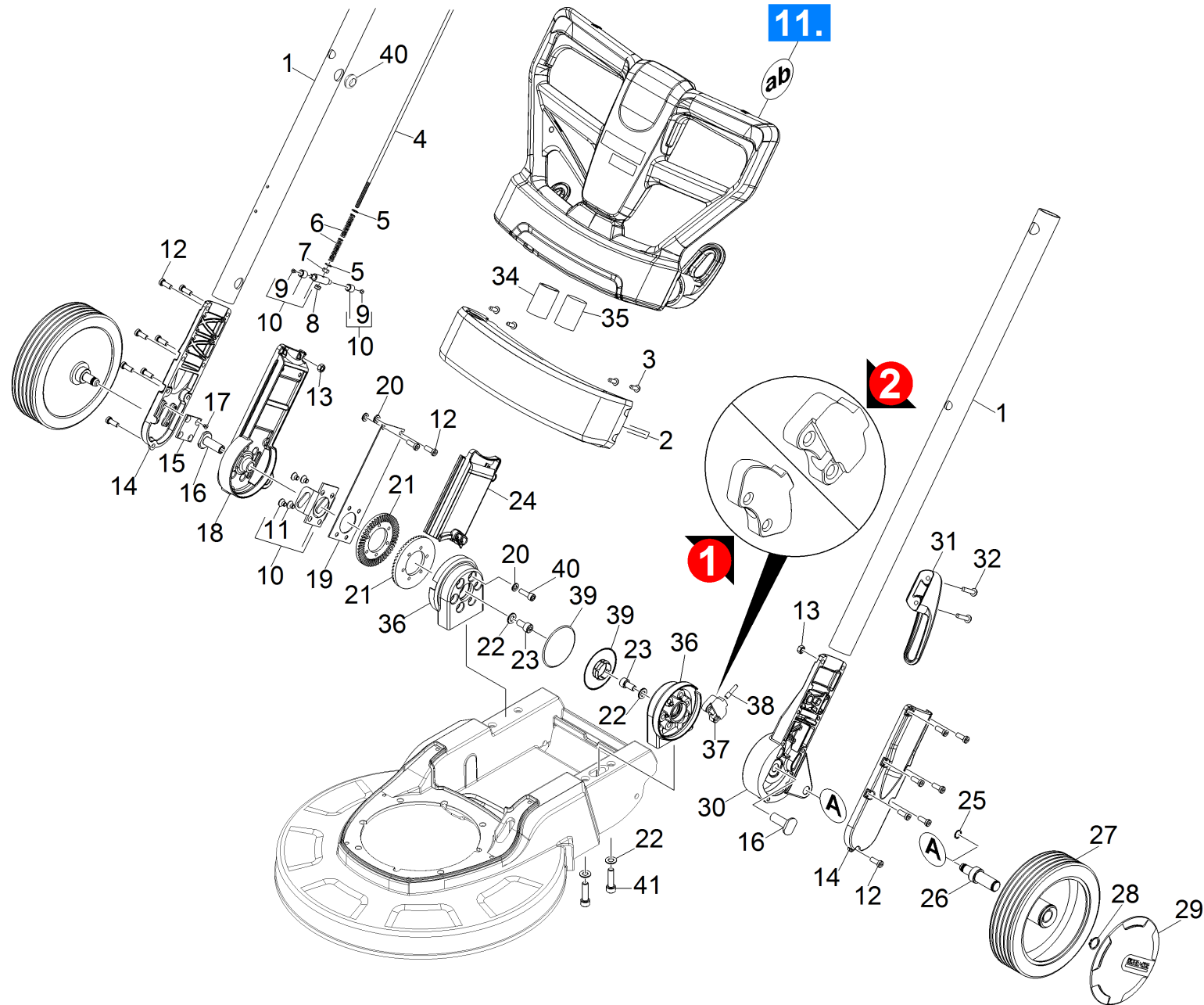

12 Handhold adjustment

Professional \ Floor cleaner \ Single disc machines \ BDS 43/180 C Adv *EU \ Spare parts list BDS 43+51/180 C \ Handhold \ Handhold adjustment



POS	Article no.	Description	Quantity	Unit	Remark	Foot note text
1	5.033-602.0	Tube hand grip	2.000	ST		
2	6.681-117.0	Set stay replacement	1.000	ST		
3	7.303-107.0	Screw 5x16 -10.9-P2R (K-In6Rd)	8.000	ST		
4	5.107-306.0	Bar	1.000	ST		
5	7.312-052.0	Washer 5 -A2 ISO 7089	2.000	ST		
6	5.332-042.0	Pressure spring	2.000	ST		
7	7.311-002.0	Hexagon nut M5 -6-A2E ISO 4032	1.000	ST		
8	7.311-421.0	Hexagon nut M 5-04-A2E DIN 985	1.000	ST		
9	7.305-035.0	Countersunk screw M 4x10-A2-70-SCHW (IN	2.000	ST		
10	6.681-116.0	Set plate replacement	1.000	ST		
11	7.305-051.0	Countersunk screw M6x8 -A2-70 (In6Rd)	4.000	ST		
12	7.306-031.0	Screw M 6x16-A2-70 DIN 7984	23.000	ST		
13	7.311-003.0	Hexagon nut M6 -8-A2E ISO 4032	4.000	ST		
14	5.044-963.0	Cover angle	2.000	ST		
15	5.039-062.0	Plate	1.000	ST		
16	5.034-906.0	Axle	2.000	ST		
17	7.305-252.0	Countersunk screw M 4x8-4.8-A2E ISO 7046	4.000	ST		
18	5.044-961.0	Angle right	1.000	ST		
19	5.039-061.0	Spring steel sheet	1.000	ST		
20	7.312-003.0	Washer 6 -200HV-A3E ISO 7089	2.000	ST		
21	2.645-220.0	Set gear ring replacement 2x	1.000	ST		
22	7.312-004.0	Washer 8 -200HV-A3E ISO 7089	6.000	ST		
23	7.306-040.0	Cylinder head screw M8x16 -8.8-A2E ISO4	4.000	ST		
24	5.050-966.0	Covering cap	1.000	ST		
25	7.343-300.0	Lock washer 7-A2 DIN 6799	2.000	ST		
26	5.034-795.0	Axle transport wheel	2.000	ST		
27	6.435-196.0	Wheel D 180	2.000	ST		
28	7.343-005.0	Locking ring 16x1-FST-PHR DIN 471	2.000	ST		
29	5.064-392.0	Wheel cap grey	2.000	ST		
30	5.044-959.0	Angle left	1.000	ST		ORDER TOGETHER WITH VERSION 2/POS. 37+38

12 Handhold adjustment

Professional \ Floor cleaner \ Single disc machines \ BDS 43/180 C Adv *EU \ Spare parts list BDS 43+51/180 C \ Handhold \ Handhold adjustment

POS	Article no.	Description	Quantity	Unit	Remark	Foot note text
31	8.621-895.0	Hook	1.000	ST		
32	7.306-158.0	Cylinder head screw M 5x20-A4-70 ISO 47	2.000	ST		
34	6.632-523.0	Capacitor start 60µF	1.000	ST		
35	6.632-524.0	Capacitor run 20µF	1.000	ST		
36	6.681-115.0	Set axle retainer replacement	1.000	ST		
37	5.044-244.0	Plate locking part	1.000	ST	VERSION 2	
38	5.034-013.0	Pin locking part	1.000	ST	VERSION 2	
39	5.033-724.0	Covering cap retainer axle	2.000	ST		
40	7.306-022.0	Cylinder head screw M 6x20-8.8-A2E ISO47	12.000	ST		
41	7.306-043.0	Cylinder head screw M8x30 -8.8-A2E ISO	4.000	ST		