

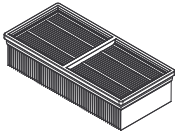



Filtersysteme / Filter Systems / Système de filtres





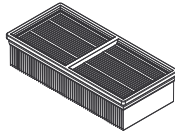
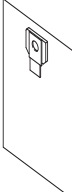

						
	Flachfaltenfilter * Flat pleated filter * Filtre plat à plis *	Papierfiltertüte, reißfest, 3-lagig * Paper filter bag, tenacious, three-fold * Sachet filtre à 3 épaisseurs, résistant à la rupture *	Membranfilter Diaphragm filter Filtre à membrane	Spezialfiltertüte, nass Special filter bag, wet Sachet filtre spécial, mouillé	Flachfaltenfilter (PES) * Flat pleated filter (PES) * Filtre plat à plis (PES) *	Vliesfiltertüte 2-lagig * Fleece filter bag double layered * Sachet filtre en tissu non tissé à 2 épaisseurs *
Bestell-Nr. Order No. Numéro de référence	6.907-276	6.904-285	6.904-282	6.904-252	6.907-277	6.904-424
Menge Quantity Quantité	1	5	1	5	1	5
Normalstäube Normal dust Poussières normales	X	X	X			X
Feinstäube Fine dust Poussières fines	X	X	X			X
Abrasive Stäube Abrasive dust Poussières abrasives	X	X	X	X		X
Flüssigkeiten, nasser Schmutz Liquids, wet dirt Liquides, saletès humides				X	X	

* Staubklasse M, Rückhaltevermögen $\geq 99,9$ %

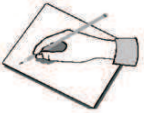
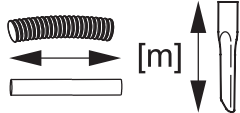
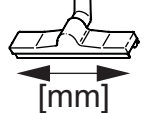
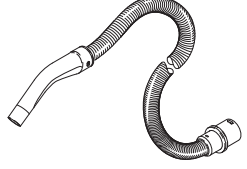
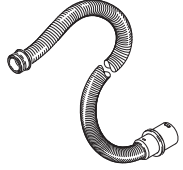



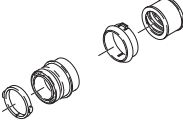

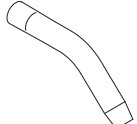
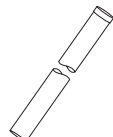
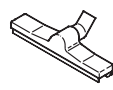
* Dust class M, Retention $\geq 99,9$ %

* Classe de poussière M, Conservation $\geq 99,9$ %

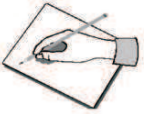
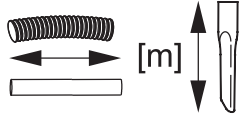
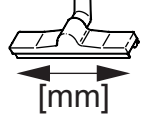
Zubehör / Accessories / Accessoires

		\emptyset [mm]		
	4.440-678 K 4.440-391 K	CDN 40 CDN 40	4,0 4,0	
	6.906-321 K 6.906-279 K 6.906-635 K 6.906-714 K/Oil	C 40 C 40 C 40 C 40	4,0 10,0 16,0 4,0	
	6.906-344 K	C 40 Verlängerung, extension, rallonge	2,5	
	5.407-109 K/EL 5.407-111 K/EL	C 40 - DN 35 C 40 - DN 40		
	5.407-113 K/EL	C 40 - C 35		
	2.639-873			
	5.031-904 K 5.032-427 K/EL	CDN 40 CDN 40		
	4.440-463 K 4.440-612 K/Oil 4.440-328 K/I	DN 40 DN 40 DN 61	10,0 10,0 5,0	
	6.900-276 M 6.902-080 M	DN 40 DN 61		
	6.902-081 M 6.906-531 M	DN 40 DN 40	0,5 1,0	
	6.906-554 K 6.903-018 M 6.906-383 M	DN 40 DN 40 DN 40		360 370 450

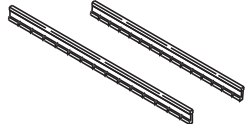
Zubehör / Accessories / Accessoires

		∅ [mm]		
	6.903-033 K 6.905-817 M 6.900-222 K 6.900-926 M	DN 40 DN 40 DN 61 DN 61	0,30 0,40 0,37 0,37	
	6.900-952 K	DN 40		90
	6.902-105 G/Oil 6.902-106 G/Oil	DN 40 DN 61	0,20 0,70	
	2.637-217 K	DN 40		
Umbausatz für nicht leitende Flüssigkeiten, Dielectric media conversion kit, Kit de modification pour les fluides non conducteurs	2.642-602			
	6.905-877 G 6.903-062 G 6.903-081 Oil 6.903-063 G 6.906-146 Oil			360 370 370 450 450
	6.905-878 K 6.904-064 K 6.904-065 K			360 370 450

EL = elektrisch leitend, electrical conductive, conducteur électrique

K = Kunststoff, Plastic, Plastique

C = Clip-Verbindung, Clip connection, Connexion de clip

DN = Konus-Verbindung, Cone connection, Connexion de cône

M = Metall, Metal, Métal

G = Gummi, Rubber, Caoutchouc

Oil = ölbeständig, oil resistant, résistant à l'huile

I = Industrie, Industrial, Industrie

NT 65/2 Tact²

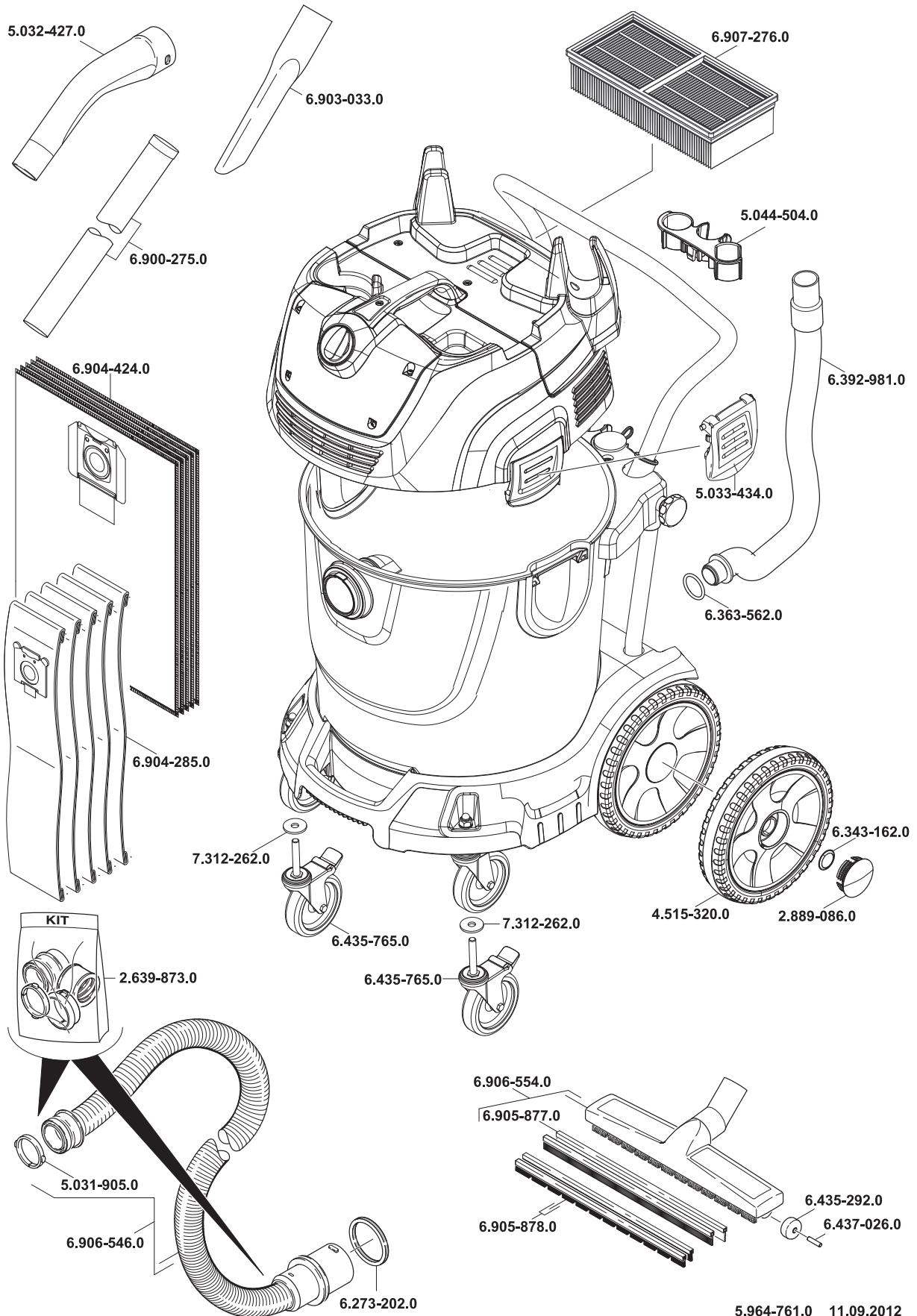

5.964-761.0 11.09.2012

NT 75/2 Tact² Me

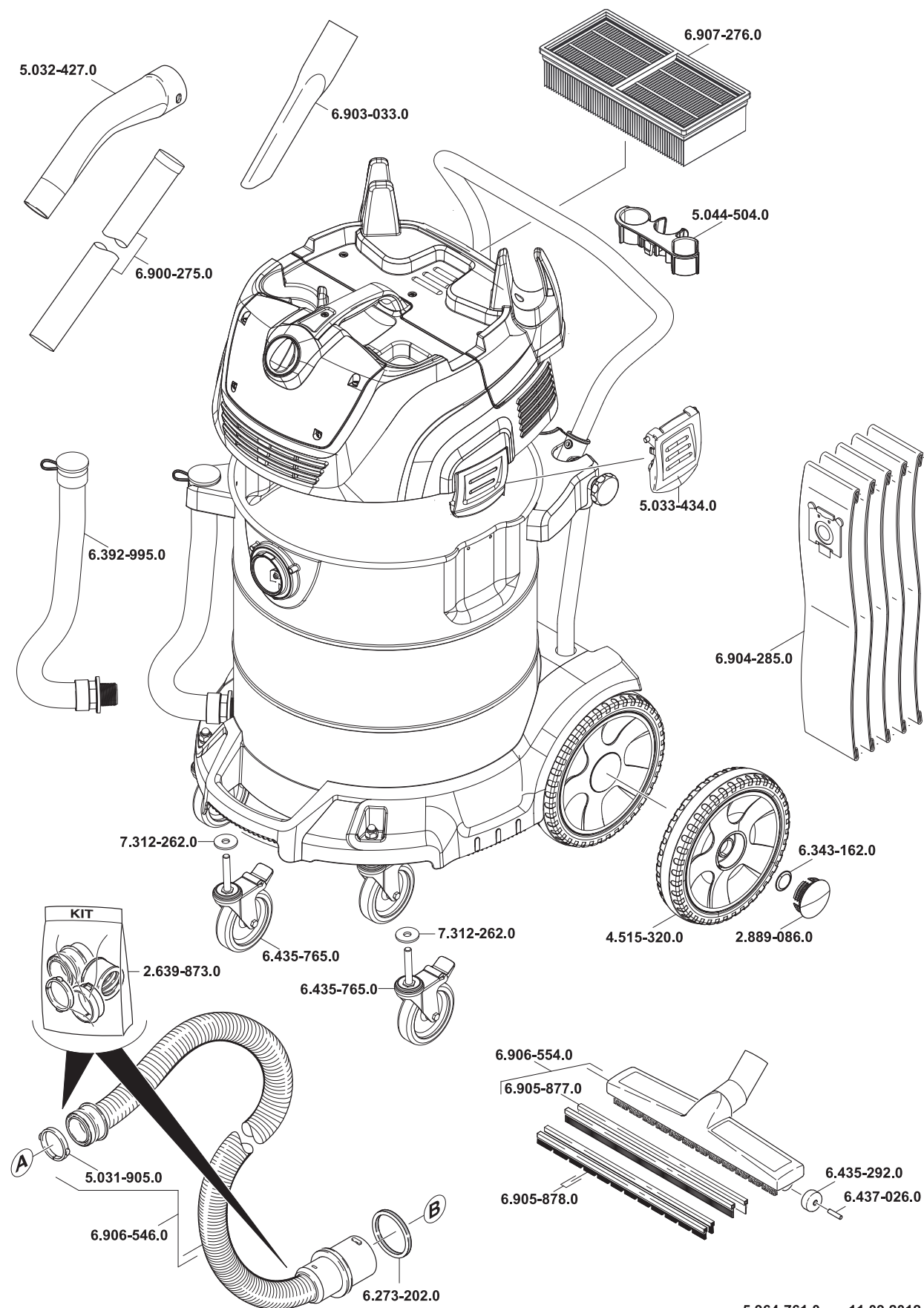

5.964-761.0 11.09.2012