

**Rezerves daļu saraksts
(5.971-160.0) Spare parts list K5.600 Modul Range**

DE HINWEISE

Weitere Sprachen:

Diese Ersatzteilliste ist in weiteren Sprachen erhältlich. Sie erhalten diese unter www.kaercher.com im Bereich Service. Die Schreibweise der Teilenummer, z.B. 75456380, entspricht der Teilenummer 7.545-638.0.

Mengenangaben:

Die Mengenangaben in der Ersatzteilliste entsprechen den in der Baugruppe verbauten Stückzahlen der Bauteile.

Meterware:

Ersatzteile welche als Meterware geliefert werden sind auf Einbaulänge selbst zu kürzen. Die Stückzahlen sind als Mindestbestellmenge =1m angegeben und müssen je nach Bedarf auf weitere volle Meterzahlen erhöht werden.

Versionen/ Werknummern:

Sind Versionen oder Werknummern in der Ersatzteilliste angegeben, ist anhand dieser vor Bestellung zu prüfen, welches Bauteil für ihr Gerät verwendet werden muss.

Lackierte Teile:

Bei Bestellungen von lackierten Teilen welche in der Ersatzteilliste nicht in verschiedenen Farben ausgewiesen sind, ist zusätzlich die Farbnummer oder Farbe mit anzugeben.

Technische Änderungen:

Technische Änderungen sowie das Recht der ausschließlichen Auswertung unseres geistigen Eigentums behalten wir uns vor.

EN INSTRUCTIONS

Other languages:

This list of spare parts is also available in other languages. You can get this list from www.kaercher.com in the Service division. The designation of the part number e.g. 75456380 is equal to 7.545-638.0.

Quantity details:

The quantity details in the spare parts list correspond to the number of pieces of the component installed in the assembly group.

Piece goods:

Spare parts that are sold as piece goods are to be cut to the desired length. The quantities have been indicated as minimum order quantity =1m and must be rounded off to the full meter figure depending on your requirements.

Version/ Plant numbers:

If version or plant numbers are mentioned in the spare parts list, then use the same to check before ordering which spare part needs to be used for your appliance.

Painted parts:

While ordering painted parts that are not mentioned in the spare parts list in their colour variations, please mention the colour number or the colour you require.

Technical changes:

We reserve the right to make technical changes as well as the right to exclusive use of our intellectual property.

FR REMARQUES

Autres langues:

Cette liste de pièces de rechange est disponible en autres langues. Cela est disponible sous www.kaercher.com dans le menu Service. La désignation du numéro de pièce, par ex. 75456380, correspond au numéro de pièce 7.545-638.0.

Indications de quantité:

Les indications de quantité dans la liste de pièces de rechange correspondre aux nombres de pièces des composant utilisées dans la construction.

Matériel au mètre:

Les pièces de rechange qui sont livrées au mètre doivent être raccourcies à longueur souhaitée par l'acheteur même. Les nombres des pièces sont indiquées en quantité de commande minimale = 1m et doivent être augmentés selon le besoin à une chiffre de mètre complète.

Versions/ Numéros d'usine:

Lorsqu'il sont indiquées des versions ou des numéros d'usine dans la liste de pièces de rechange, vous devez vérifier que composant doit être utilisé pour votre appareil.

Pièces laquées:

Pour commander des pièces laquées, où les différentes couleurs ne sont pas indiquées dans la liste des pièces de rechange, vous devez indiquer en plus le numéro de la couleur ou seulement la couleur.

Modifications techniques:

Nous nous réservons la possibilité des modifications techniques ainsi le droit d'exploitation exclusive de notre propriété intellectuelle.

IT AVVERTENZE

Altre lingue:

Il presente elenco di parti di ricambio è disponibile sul nostro sito Web anche in altre lingue: sotto www.kaercher.com alla voce "Service".

L'indicazione del codice pezzo, ad es. 75456380, corrisponde al codice pezzo 7.545-638.0

Indicazioni di quantità:

Le indicazioni di quantità riportate dall'elenco "parti di ricambio" corrispondono al numero delle singole componenti contenute nella rispettiva unità.

Merce a metro:

Le parti di ricambio fornite come "merce a metro" devono venire in seguito accorciate alla lunghezza necessaria per il montaggio. La quantità unitaria è indicata come "quantità minima di ordinazione = 1m" e deve all'occorrenza venire moltiplicata per il numero intero di metri necessari.

Versioni / Numeri di fabbricazione:

Quando l'elenco "parti di ricambio" riporta diverse versioni o numeri di fabbricazione, confrontare la versione o il numero di fabbricazione del ricambio desiderato con quelle/i presenti nell'elenco e indicarla/o al momento dell'ordinazione.

Parti di ricambio verniciate:

Nel caso di ricambi verniciati, se l'elenco parti di ricambio non ne riporta espressamente i diversi colori, al momento dell'ordinazione è necessario indicare anche il colore o il numero del colore desiderato.

Modifiche tecniche:

Ci riserviamo il diritto di apportare modifiche tecniche così come il diritto di utilizzo esclusivo della nostra proprietà intellettuale.

ES INDICACIONES

Otros idiomas:

La lista de piezas de repuesto se puede adquirir en otros idiomas. La puede adquirir en www.kaercher.com en el área de servicios.

La notación de los números de las piezas, p.ej. 75456380 corresponde al número de pieza 7.545-638.0.

Cantidades:

Las indicaciones de cantidades de la lista de piezas de repuesto corresponden al número de piezas montadas en el componente.

Mercancía por metros:

Las piezas de repuesto que se suministran por metros se pueden cortar al largo deseado. La unidad mínima de pedido es de = 1 m y el número de metros completos se puede aumentar según necesidad.

Versiones/números de fábrica:

Si se indica la versión o número de fábrica en la lista de piezas de repuesto, se debe comprobar en ella la pieza a usar para su aparato antes de realizar el pedido.

Piezas lacadas:

Al realizar pedidos de piezas lacadas que no estén indicadas en los diferentes colores en la lista de piezas de repuesto, se debe indicar también la referencia del color o el color.

Modificaciones técnicas:

Reservados los derechos de realizar modificaciones técnicas y aprovechar nuestra propiedad intelectual.

PL WSKAZÓWKI

Pozostałe języki:

Ta lista części zamiennych jest dostępna w także w innych językach. Mogą ją Państwo pobrać ze strony www.kaercher.com w dziale Serwis.

Sposób zapisywania numeru części, np. 75456380, odpowiada numerowi części 7.545-638.0.

Dane ilości:

Dane ilości podane w liście części zamiennych odpowiadają liczbie sztuk podzespołów tworzących dany moduł.

Towar sprzedawany na metry:

Części zamienne dostarczane jako towar sprzedawany na metry po zamontowaniu należy samodzielnie skrócić do potrzebnej długości. Liczba sztuk podana jest jako minimalna ilość zamówienia = 1m i w zależności od potrzeb zwiększa się ją o kolejne pełne metry.

Wersje/ Numer zakładu:

Jeżeli w liście części zamiennych podane są wersje lub numery zakładu, przed zamówieniem na ich podstawie należy sprawdzić, który podzespół stosuje się w Państwa urządzeniu.

Części lakierowane:

W przypadku zamówień części lakierowanych, które w liście części zamiennych nie podano w wielu kolorach, należy dodatkowo zaznaczyć nr koloru lub kolor.

Zmiany techniczne:

Zastrzegamy sobie prawo do zmian technicznych oraz wyłącznego wykorzystywania naszej własności intelektualnej.

RU УКАЗАНИЯ:

Другие языки:

Данный список запасных частей также доступен на других языках. Вы найдете его на сайте www.kaercher.com в разделе Service
Маркировка номера детали, например, 75456380, соответствует номеру детали 7.545-638.0.

Указание количества:

Количественные данные в списке запасных частей соответствуют числу компонентов, входящих в состав узлов.

Товар, продаваемый на метры:

Запасные части, продающиеся на метры, необходимо обрезать до нужной длины. Число изделий указано в виде минимального объема заказа = 1м и их количество можно округлить до требуемого по мере необходимости.

Варианты исполнения/заводские номера:

Если варианты исполнения или заводские номера указаны в списке запасных частей, то перед заказом необходимо проверить, какая деталь подходит для вашего устройства.

Лакированные детали:

При заказе лакированных деталей, варианты расцветки которых не указаны в списке запасных частей, необходимо дополнительно указать номер цвета или необходимый для вас цвет.

Технические изменения:

Мы оставляем за собой право на технические изменения, а также право на исключительное использование нашей интеллектуальной собственности.

Spare parts list K5.600 Modul Range (5.971-160.0)	6
10 Housing	7
20 Pump set	9
21 Housing	10
23 Nozzle insert (4.769-035.0)	13
22 Thrust guidance	16
30 Motor	18
40 Accessories	20
41 Hand trigger gun	21
0 Hose coupling (2.642-172.0)	23
42 Jet pipe	25
2 Spare part set (4.760-527.0)	27
3 Dirt blaster 031 St - CEM 14,5MPa (4.764-281.0)	29
7 WB 100 washing brush (2.643-236.0)	31
43 Surface cleaner	33
1 single step jet pipe (2.643-240.0)	35
44 Surface cleaner	37
1 single step jet pipe (2.643-240.0)	39
7 Spare parts nozzles T-Racer (2.643-338.0)	41
50 Electric box	44

Spare parts list K5.600 Modul Range (5.971-160.0)

Poz.	Nosaukums	Daudzums	Pārdoš. vienība
10	Housing	1.000	ST
20	Pump set	1.000	ST
30	Motor	1.000	ST
40	Accessories	1.000	ST
50	Electric box	1.000	ST

10 Housing

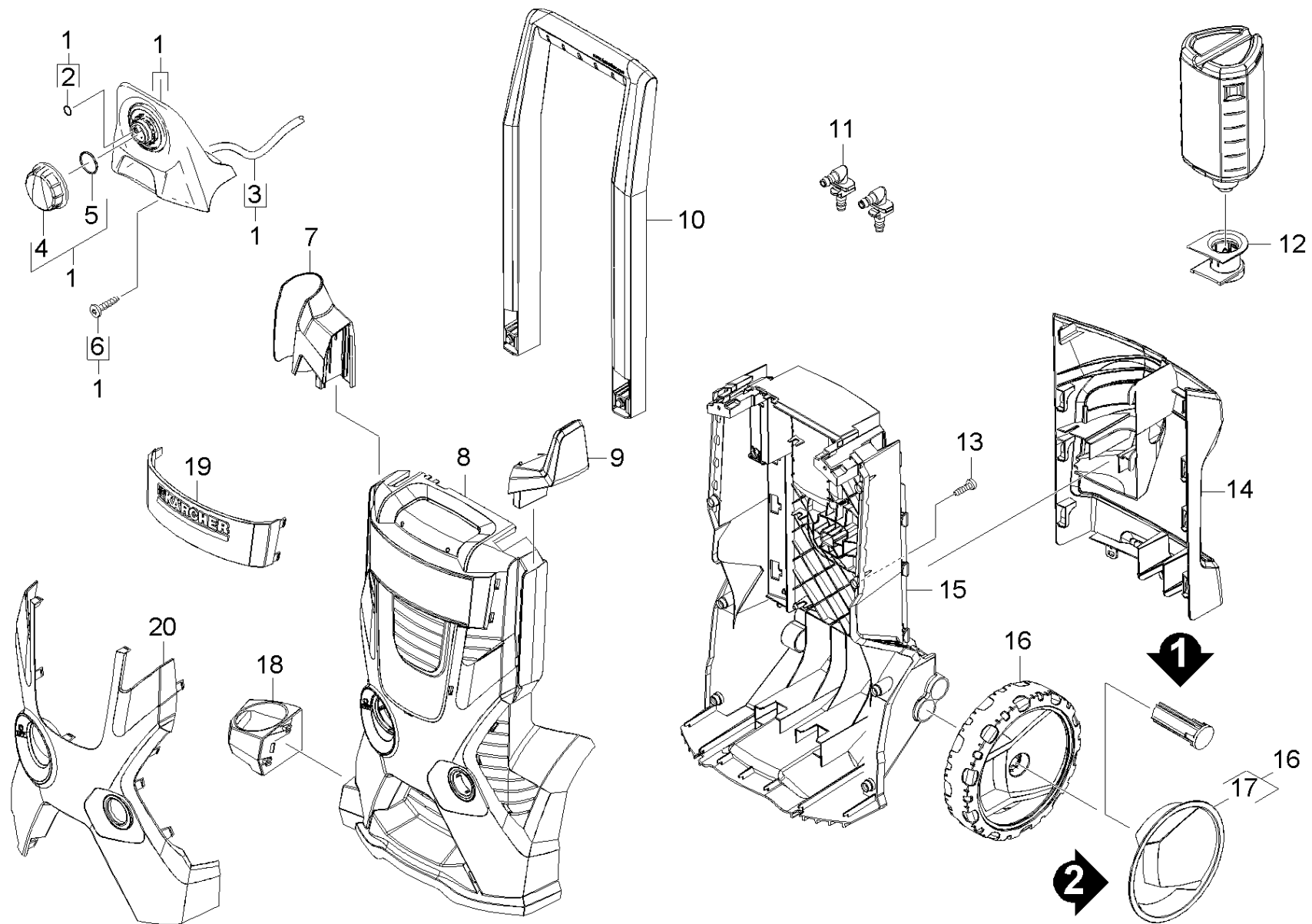

10 Housing

Rez.daļas/nodil.pakļ.daļas	Poz.	Materiāla Nr.	Nosaukums	Daudzums	Pārdoš. vienība
	1	2.885-283.0	spare part set	1.000	ST
	2	6.363-018.0	O-Ring seal 4X2	1.000	ST
	3	6.390-426.0	Hose DN 5	1.000	M
	4	9.037-621.0	Handhold chemistry	1.000	ST
	5	6.362-522.0	O-Ring seal 24,0 X 2,0	1.000	ST
	6	9.086-203.0	Screw	2.000	ST
X	7	9.037-618.0	Pistoles turētājs, augšējais	1.000	ST
	8	9.038-016.0	Cover	1.000	ST
Pozīcijas teksts: 1.181-209.0 /-217.0					
	8	9.037-634.0	Modulārais vāks	1.000	ST
Pozīcijas teksts: 1.181-200.0 /-201.0 /-202.0 /-203.0/-204.0 /-205.0 /-212.0 /-213.0					
X	9	9.037-622.0	Vada fiksators	1.000	ST
	10	9.037-626.0	Modular telescopic handle	1.000	ST
	11	9.037-861.0	Nipple 90° Mod.Range	2.000	ST
	12	9.012-681.0	RM aiztura stacija	1.000	ST
	13	9.086-173.0	Skrūve Hi-Lo d.4x22 Torx-d.7,5	8.000	ST
	13	9.086-221.0	Screw ATF 4.1x22	8.000	ST
Pozīcijas teksts: 1.181-200.0/-217.0					
X-X	14	9.038-023.0	Piederumu turētājs EU-USA	1.000	ST
	15	9.037-871.0	Aizmugures korpuss ACM modulārais	1.000	ST
X-X	16	4.515-325.0	wheel set	1.000	ST
	17	4.515-292.0	Screen for replacement	1.000	ST
X	18	9.037-619.0	Pistoles turētājs, apakšējais	1.000	ST
	19	9.001-766.0	set covering cap	1.000	ST
	20	9.037-630.0	Vāks, dzeltens X -TOP	1.000	ST

20 Pump set

Poz.	Nosaukums	Daudzums	Pārdoš. vienība
21	Housing	1.000	ST
22	Thrust guidance	1.000	ST

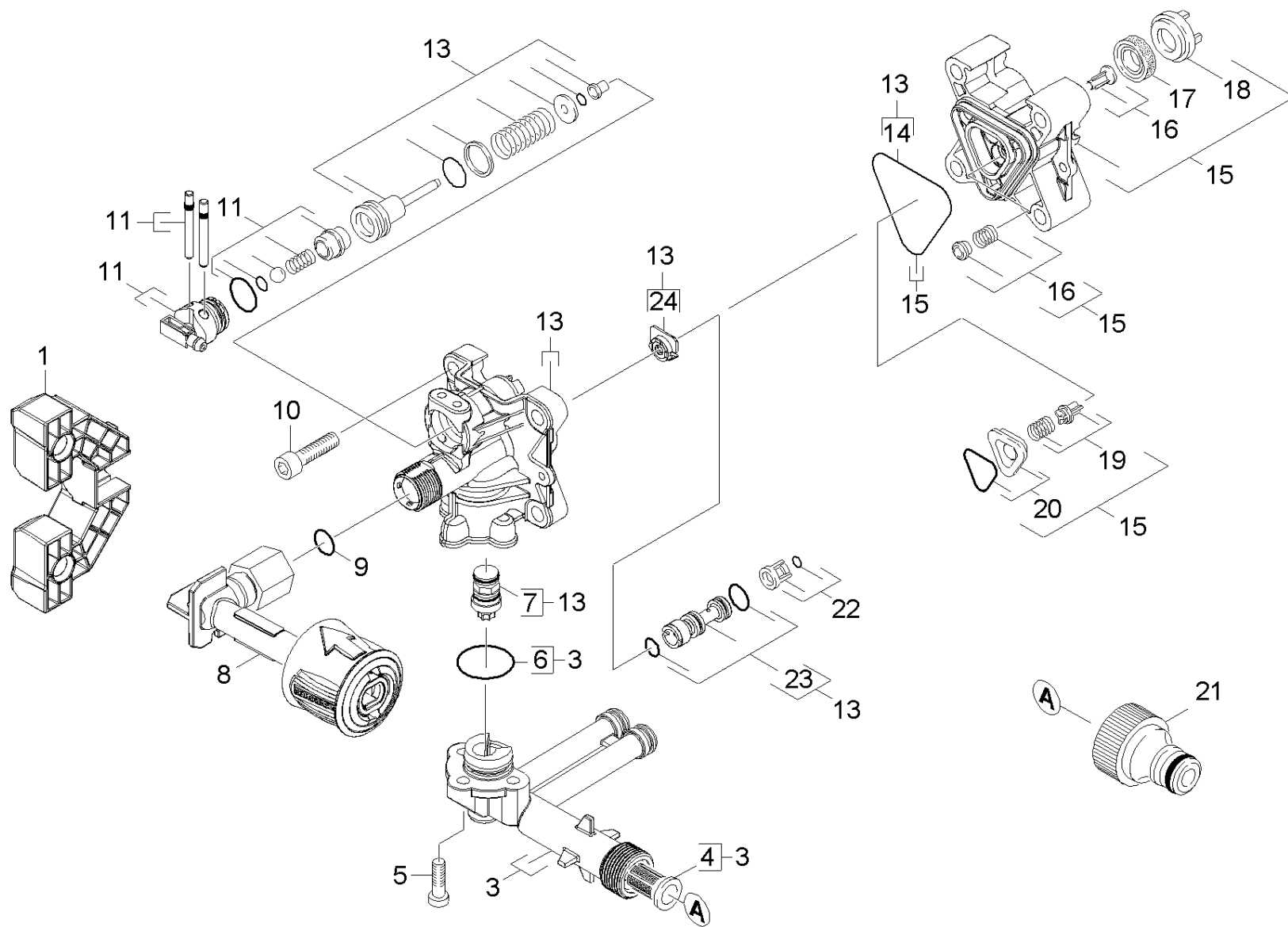

21 Housing

Rez.daļas/nodil.pakļ.daļas	Poz.	Materiāla Nr.	Nosaukums	Daudzums	Pārdoš. vienība	no sēr. Nr..	līdz sēr. Nr.
	1	9.037-673.0	Sūkņa balstenis (tilts)	1.000	ST		
X-X	3	9.001-745.0	Savienotājs, pilns komplekts	1.000	ST	0000000000	0000000000
	4	5.731-598.0	Smalkais filtrs, garš	1.000	ST	0000000000	0000000000
	5	9.086-199.0	Screw M6x16	3.000	ST	0000000000	0000000000
	6	9.081-417.0	Blīvgredzens d.20 x 2	1.000	ST	0000000000	0000000000
	7	9.002-164.0	plastic by pass (spare)	1.000	ST	0000000000	0000000000
X-X	8	9.001-746.0	Sāna padeves savienojums	1.000	ST	0000000000	0000000000
	9	6.362-151.0	Gredzenblīve 10 x 2 NBR 70	1.000	ST	0000000000	0000000000
	10	7.306-151.0	Cylinder head screw M8x65 -8.8-A2E ISO4	4.000	ST	0000000000	0000000000
	11	9.001-277.0	Ķīmijas daļu kompl.	1.000	ST	0000000000	0000000000
	13	9.001-800.0	Sadales galvas rezerves daļu komplekts	1.000	ST	0000000000	0000000000
	14	9.081-424.0	Form seal	1.000	ST	0000000000	0000000000
X	15	9.002-188.0	Pump head Alu (9001-2740) new oil seal	1.000	ST		
Pozīcijas teksts: 1.180-200.0/-217.0/-218.0/-230.0							
X-X	15	9.001-274.0	Sadales galvas rezerves daļu komplekts	1.000	ST	0000000000	0000000000
Pozīcijas teksts: all other machines							
	16	9.001-110.0	Veidnes detaļa, pilns komplekts	1.000	ST	0000000000	0000000000
X	17	6.362-875.0	Gredzens ar gropi	3.000	ST	0000000000	0000000000
	18	9.037-059.0	Balstgredzens	3.000	ST	0000000000	0000000000
Pozīcijas teksts: all other machines							
X	18	9.038-428.0	Supportring 6,7 mm	3.000	ST		
Pozīcijas teksts: 1.180-200.0/-217.0/-218.0/-230.0							
	19	9.001-275.0	Vārstu komplekts	1.000	ST	0000000000	0000000000
	20	9.001-276.0	Savienotājdetaļa	1.000	ST	0000000000	0000000000
	21	6.465-031.0	connection	1.000	ST	0000000000	0000000000

21 Housing

Rez.daļas/nodil.pakļ.daļas	Poz.	Materiāla Nr.	Nosaukums	Daudzums	Pārdoš. vienība	no sēr. Nr..	līdz sēr. Nr.
	22	9.001-819.0	Aptvere, pilns komplekts	1.000	ST	0000000000	0000000000
	23	4.769-035.0	Nozzle insert	1.000	ST	0000000000	0000000000
	24	9.037-142.0	Atstatuma turētājs	1.000	ST	0000000000	0000000000

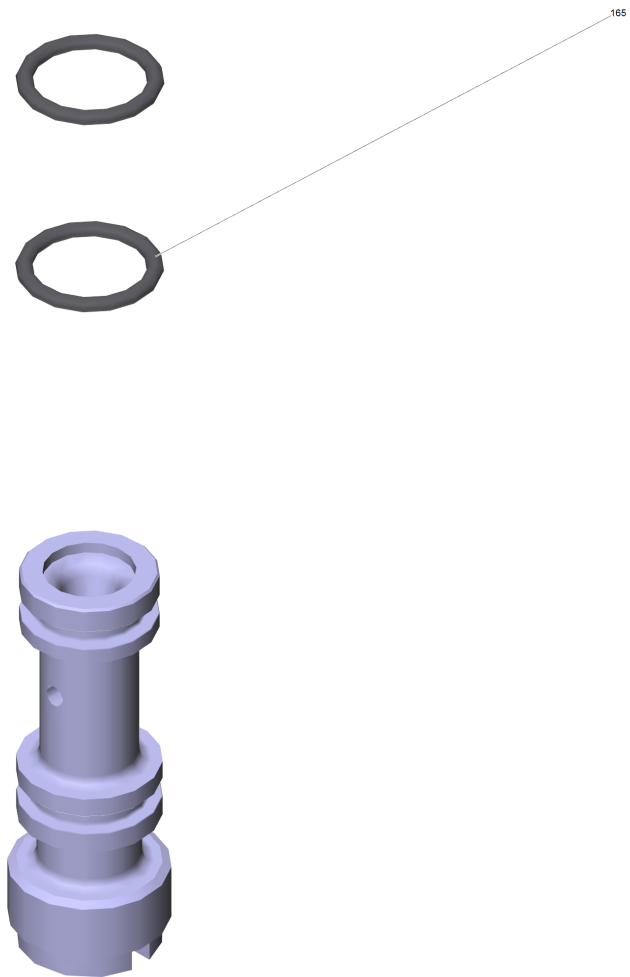

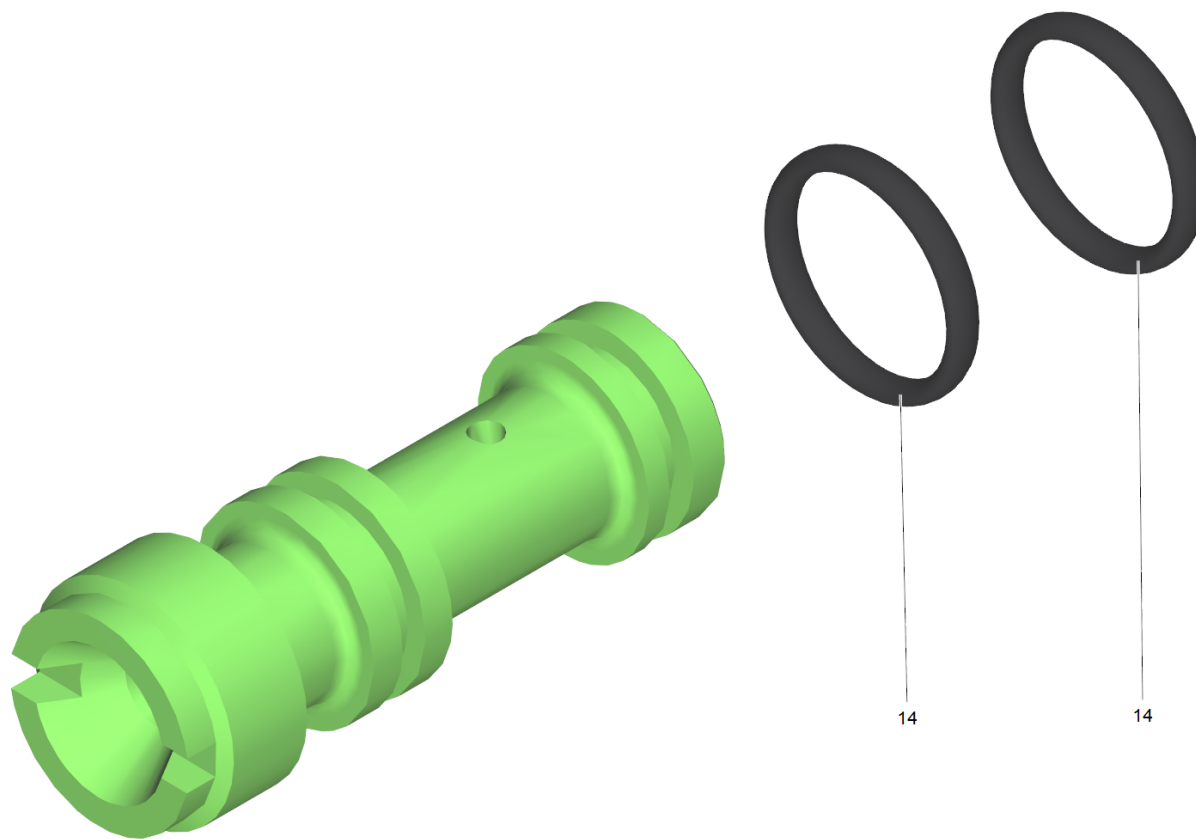

23 Nozzle insert (4.769-035.0)

Poz.	Materiāla Nr.	Nosaukums	Daudzums	Pārdoš. vienība
165	6.362-384.0	Gredzenblīve 9x1,5 - NBR 70	2.000	ST

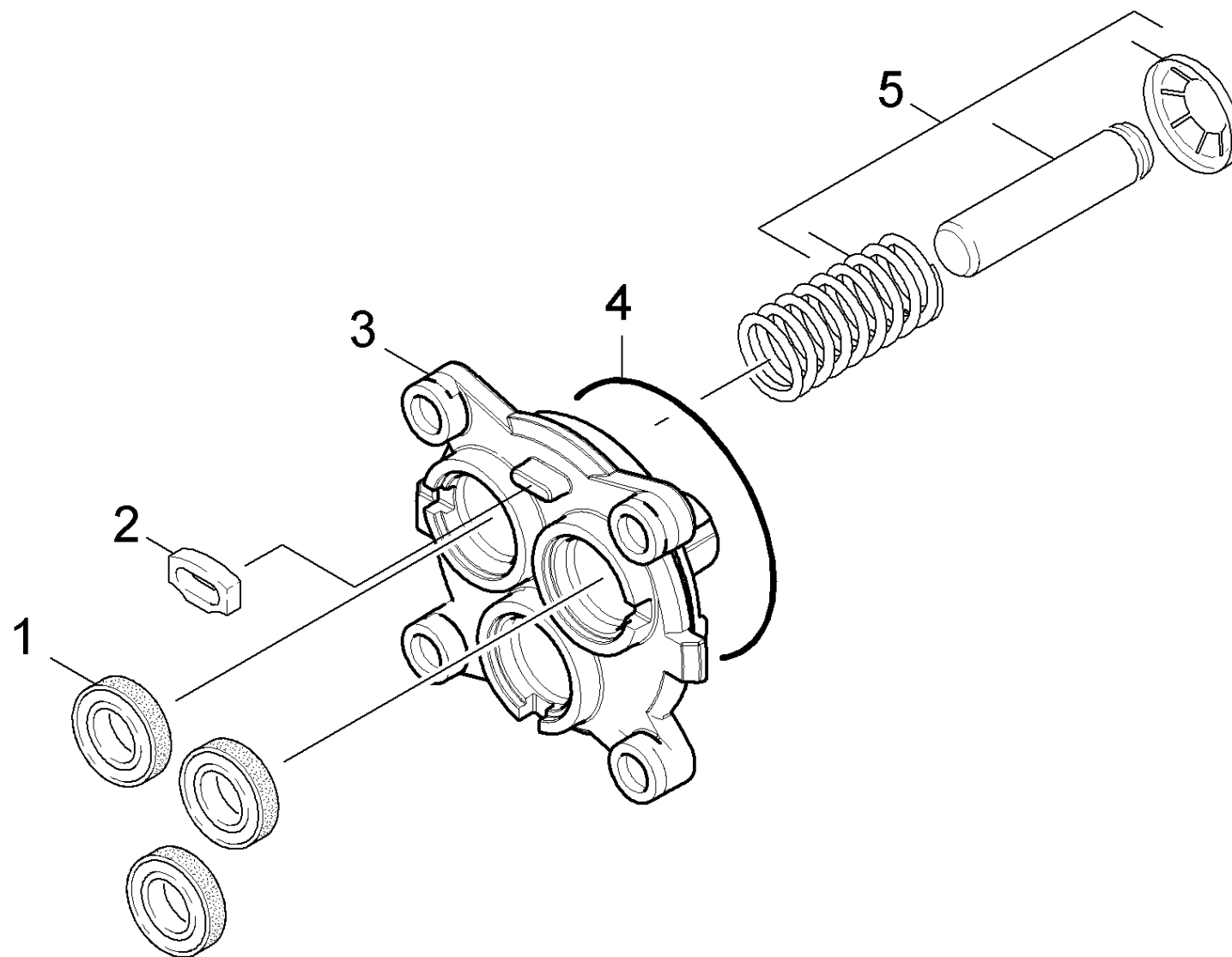

22 Thrust guidance

Rez.daļas/nodil.pakļ.daļas	Poz.	Materiāla Nr.	Nosaukums	Daudzums	Pārdoš. vienība
	1	6.964-026.0	Gredzens ar gropi	3.000	ST
	2	9.048-071.0	Starplika	1.000	ST
	3	9.042-085.0	Taisnvirziena vadotne	1.000	ST
	4	9.080-426.0	Gredzenblīve 62x3 NBR 70Shore	1.000	ST
X	5	9.001-927.0	Piston complete	3.000	ST

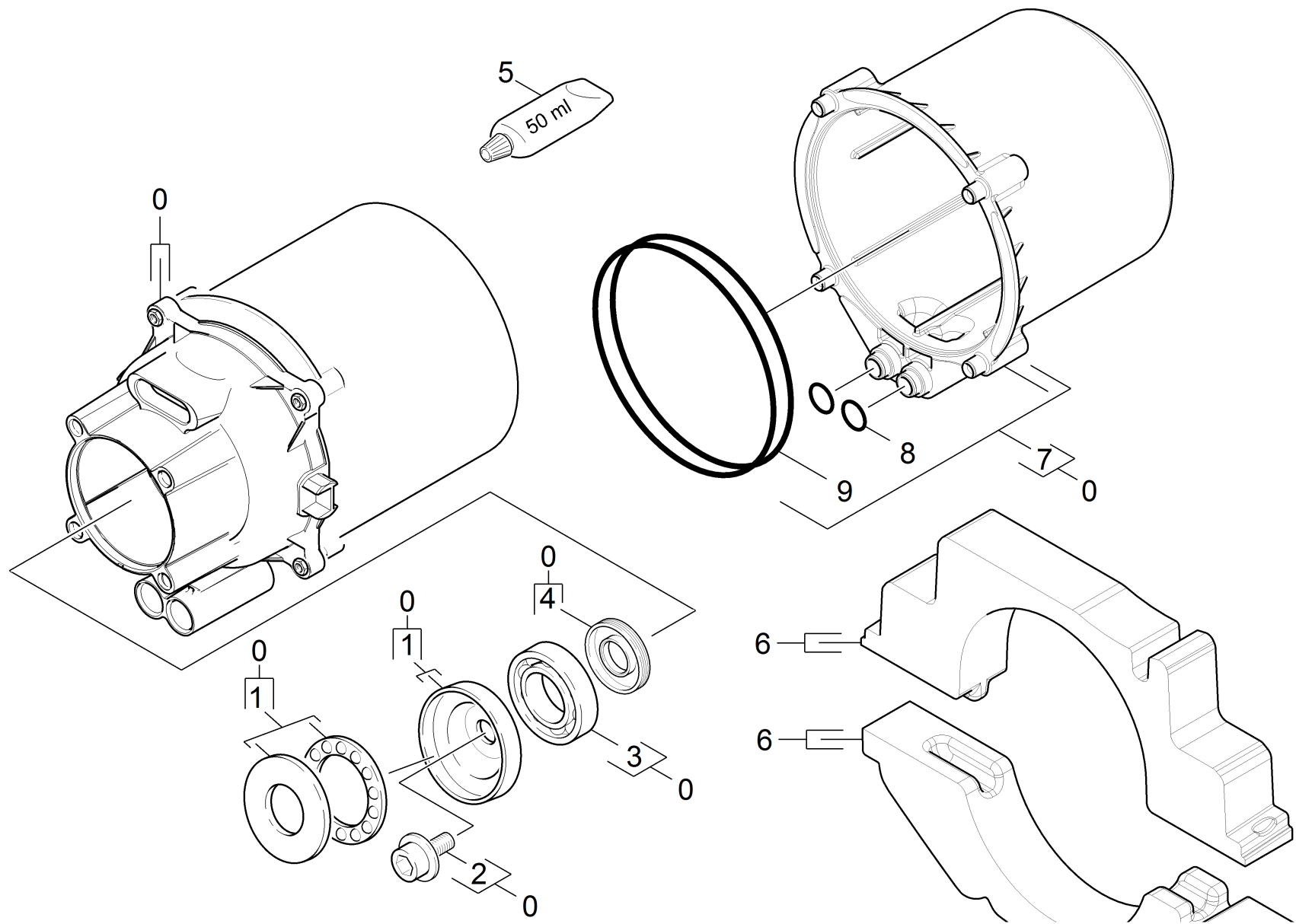

30 Motor

Rez.daļas/nodil.pakļ.daļas	Poz.	Materiāla Nr.	Nosaukums	Daudzums	Pārdoš. vienība
	0	9.001-814.0	Motors, pilns komplekts	1.000	ST
	1	9.001-880.0	Slīpā paplāksne, pilns komplekts 11°45'	1.000	ST
	2	9.086-205.0	Screw	1.000	ST
	3	7.401-010.0	Lodīšu gultnis 6303 -St DIN 625	1.000	ST
	4	9.078-007.0	Rotary shaft seal 17x35x5	1.000	ST
	5	6.964-092.0	Viskoza eļļa 50 ml	1.000	ST
	6	9.001-799.0	web	1.000	ST
X	7	9.001-918.0	Motora vāks	1.000	ST
X	8	9.080-455.0	Seal 10x2,8	2.000	ST
X-X	9	9.080-453.0	O-Ring seal 95x6	2.000	ST

40 Accessories

Poz.	Nosaukums	Daudzums	Pārdoš. vienība	Daž. informācija
41	Hand trigger gun	1.000	ST	
42	Jet pipe	1.000	ST	
43	Surface cleaner	1.000	ST	T 200
44	Surface cleaner	1.000	ST	T 250

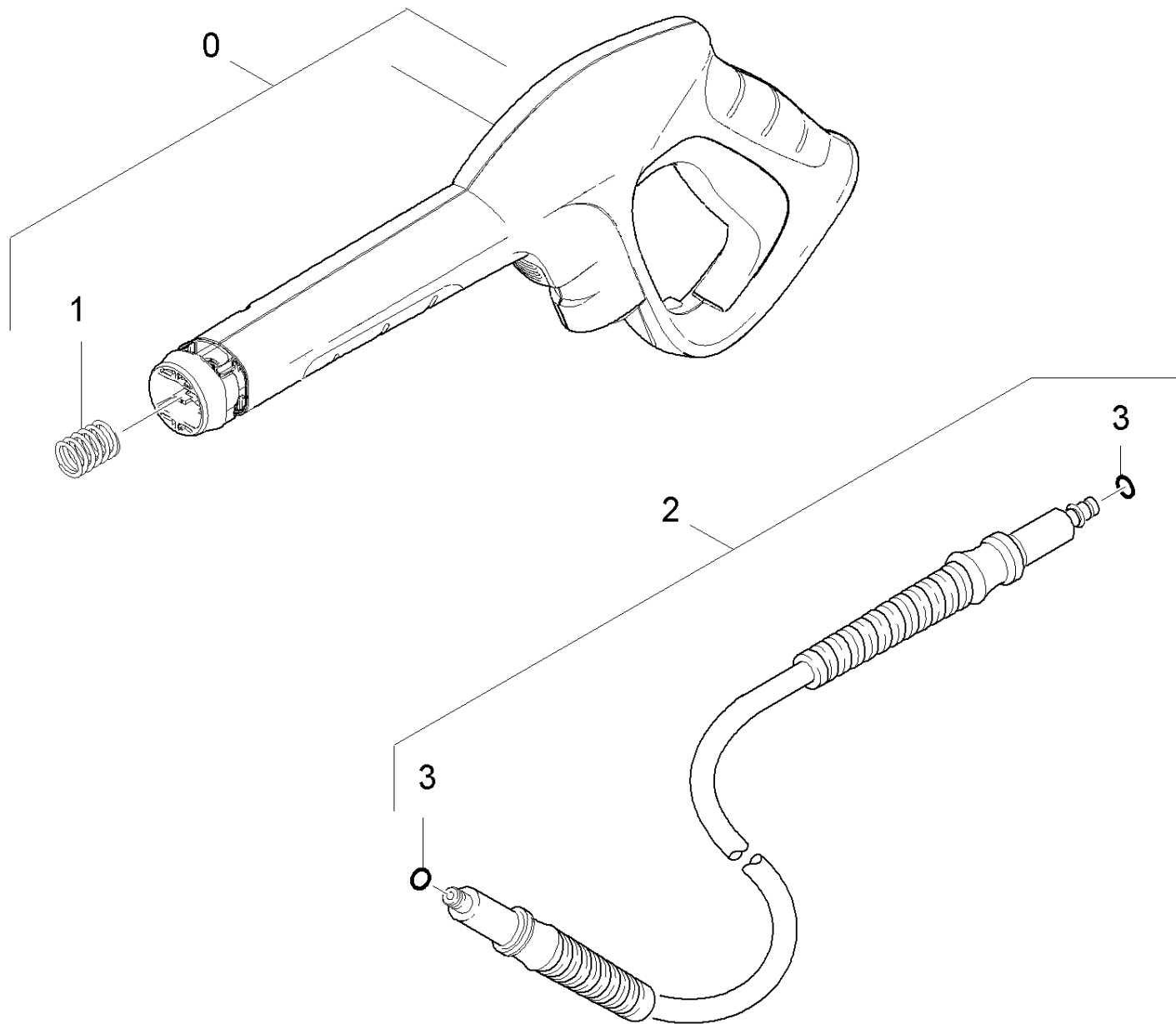

41 Hand trigger gun

Poz.	Materiāla Nr.	Nosaukums	Daudzums	Pārdoš. vienība
0	2.642-172.0	Hose coupling	1.000	ST
1	5.332-464.0	Pressure spring	1.000	ST
2	2.641-721.0	High pressure hose 9m, K3 - K7	1.000	ST
3	6.363-410.0	Gredzenblīve 5,7x1,78 NBR 90Shore	2.000	ST



0 Hose coupling (2.642-172.0)

Poz.	Materiāla Nr.	Nosaukums	Daudzums	Pārdoš. vienība
1	5.332-464.0	Pressure spring	1.000	ST

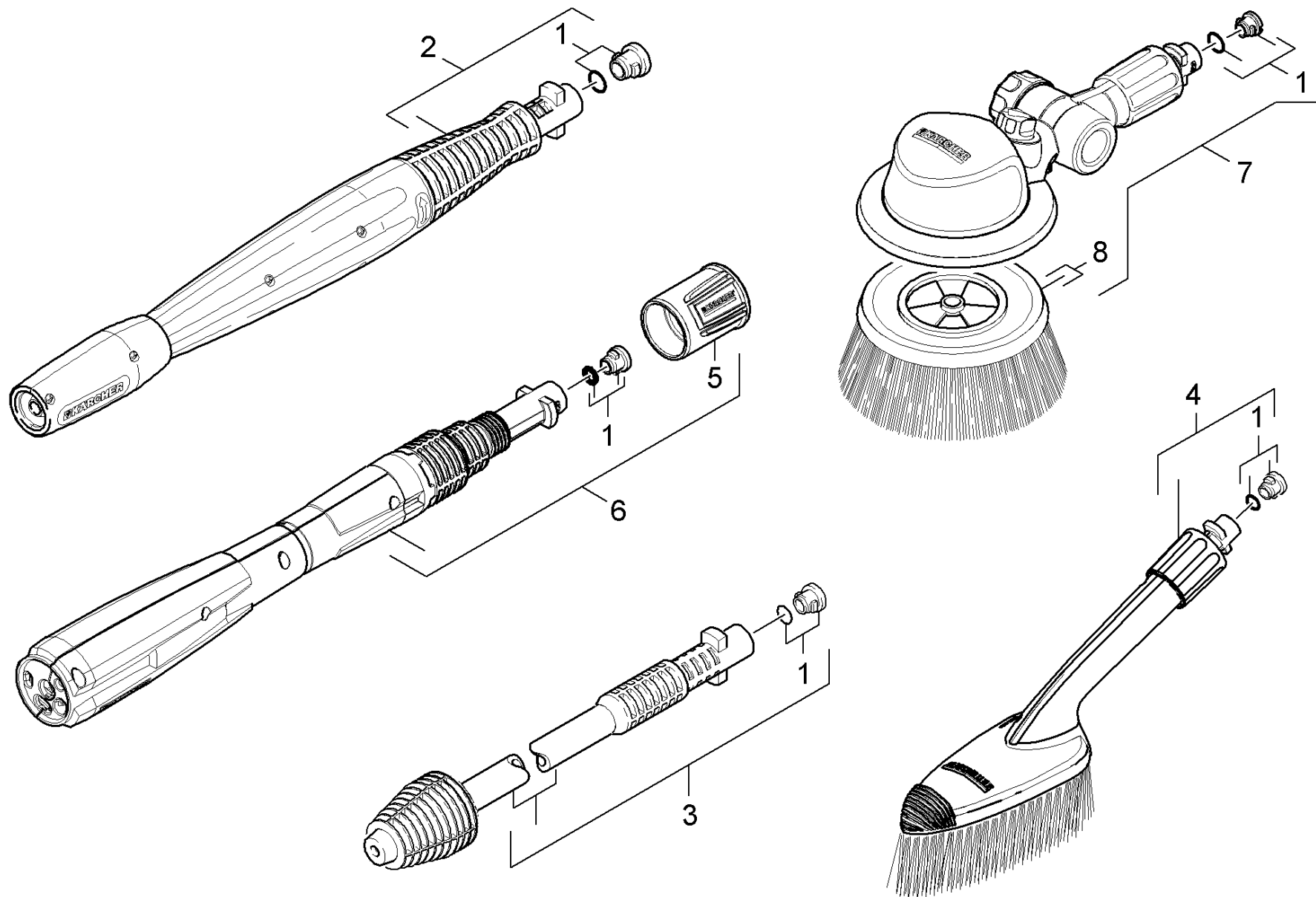

42 Jet pipe

Rez.daļas/nodil.pakļ.daļas	Poz.	Materiāla Nr.	Nosaukums	Daudzums	Pārdoš. vienība	no sēr. Nr..	līdz sēr. Nr.
	1	2.640-729.0	O-Ring seal set	1.000	ST	0000000000	0000000000
	2	4.760-527.0	Spare part set	1.000	ST	0000000000	0000000000
X	3	4.764-281.0	Dirt blaster 031 St - CEM 14,5MPa	1.000	ST	0000000000	0000000000
	4	2.640-589.0	Universal soft brush	1.000	ST	0000000000	0000000000
	5	5.310-160.0	Nut Kaercher	1.000	ST		
	6	4.764-233.0	Multi-Power-Jet 028	1.000	ST		
X	7	2.643-236.0	WB 100 washing brush	1.000	ST		
	8	5.762-331.0	switch complete	1.000	ST		

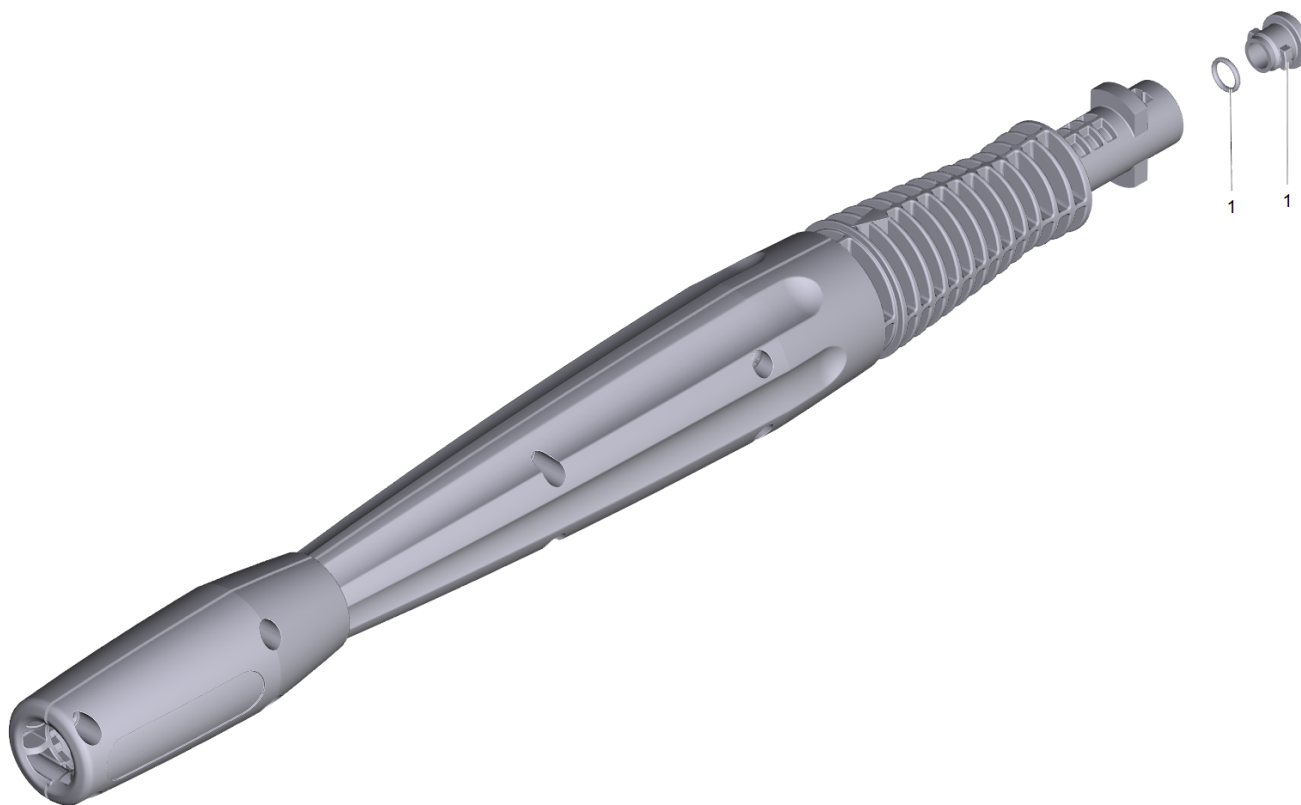

2 Spare part set (4.760-527.0)

Poz.	Materiāla Nr.	Nosaukums	Daudzums	Pārdoš. vienība
1	2.640-729.0	O-Ring seal set	1.000	ST

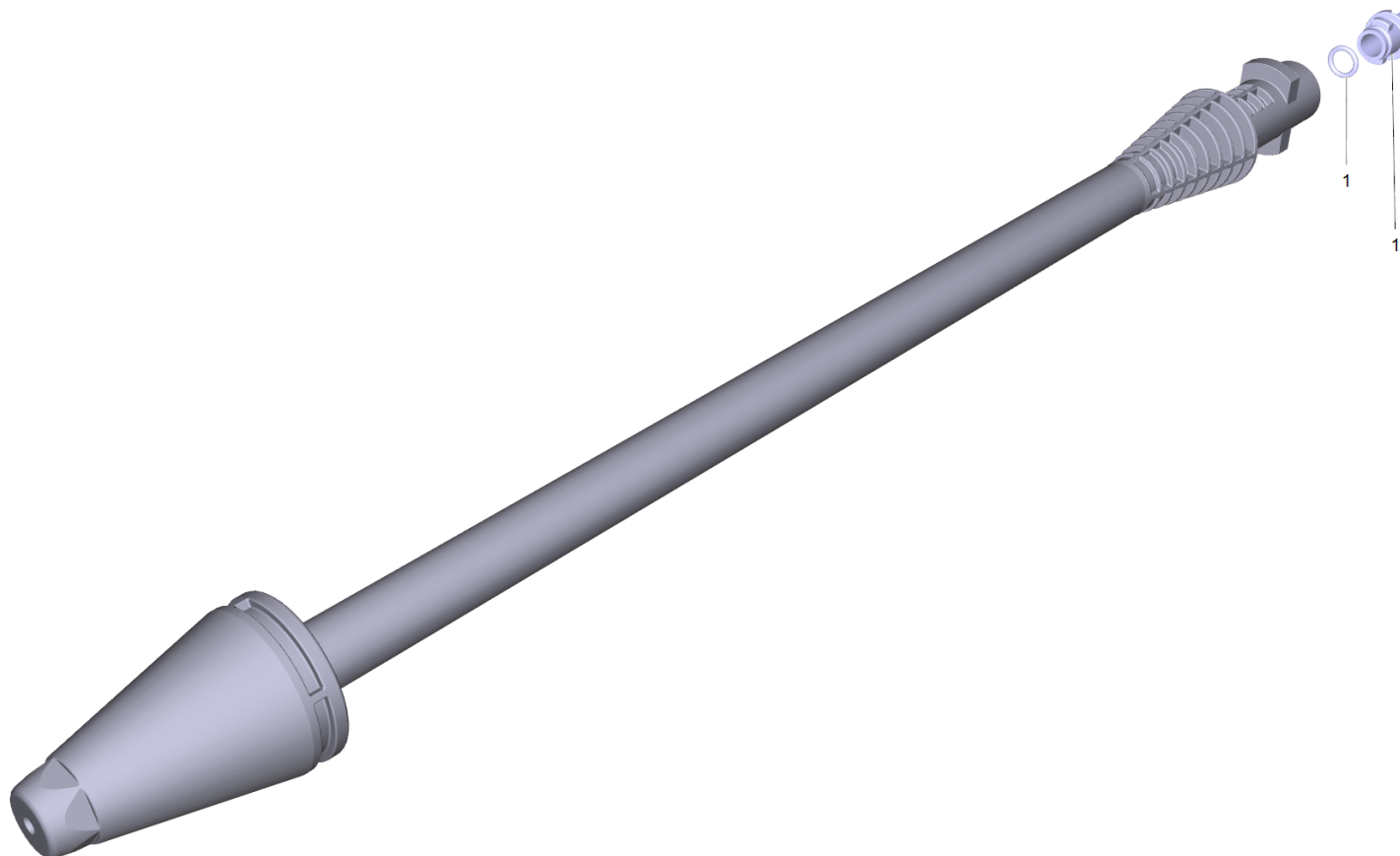

3 Dirt blaster 031 St - CEM 14,5MPa (4.764-281.0)

Poz.	Materiāla Nr.	Nosaukums	Daudzums	Pārdoš. vienība
1	2.640-729.0	O-Ring seal set	1.000	ST

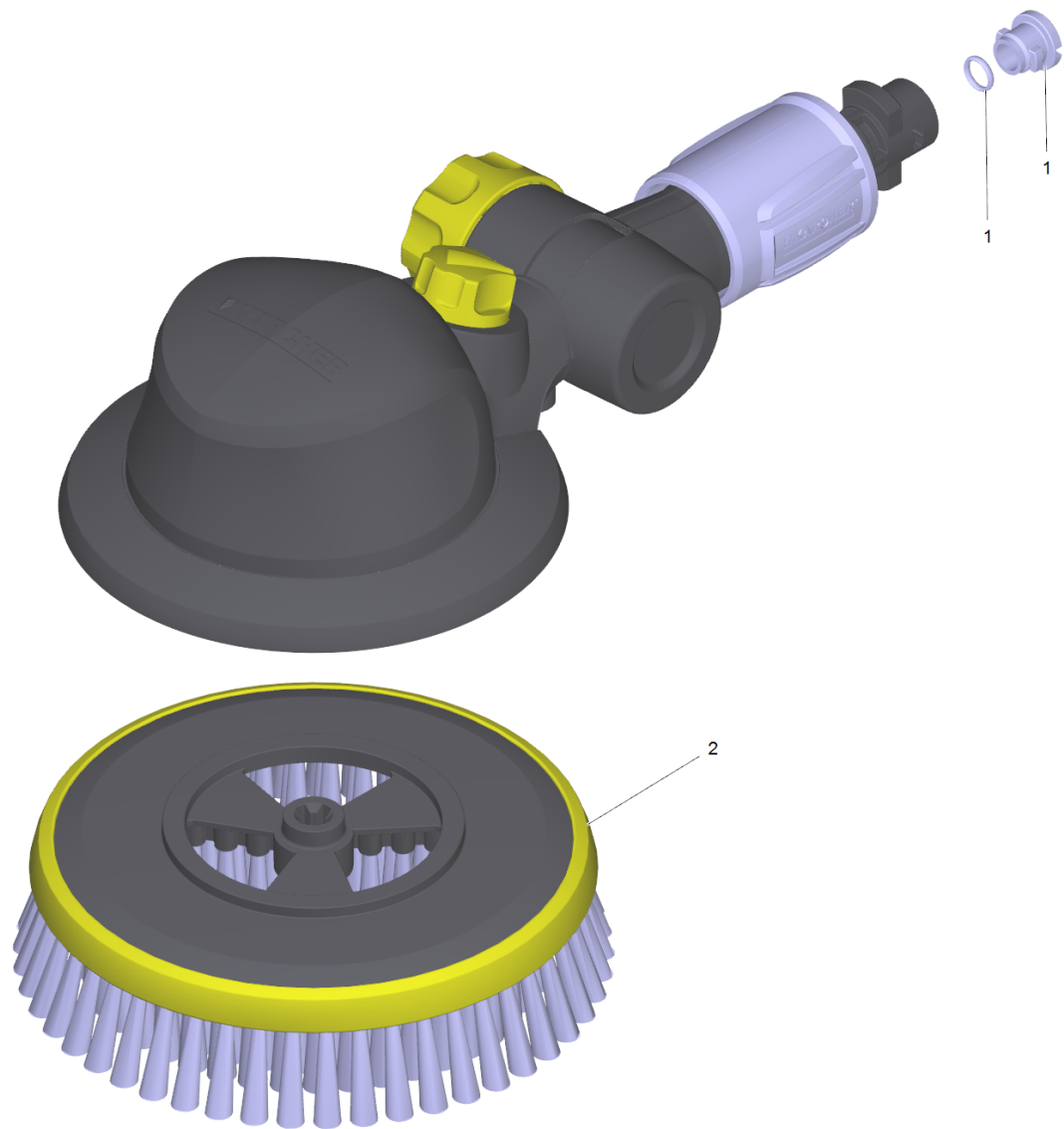

7 WB 100 washing brush (2.643-236.0)

Poz.	Materiāla Nr.	Nosaukums	Daudzums	Pārdoš. vienība
1	2.640-729.0	O-Ring seal set	1.000	ST
2	5.762-331.0	switch complete	1.000	ST

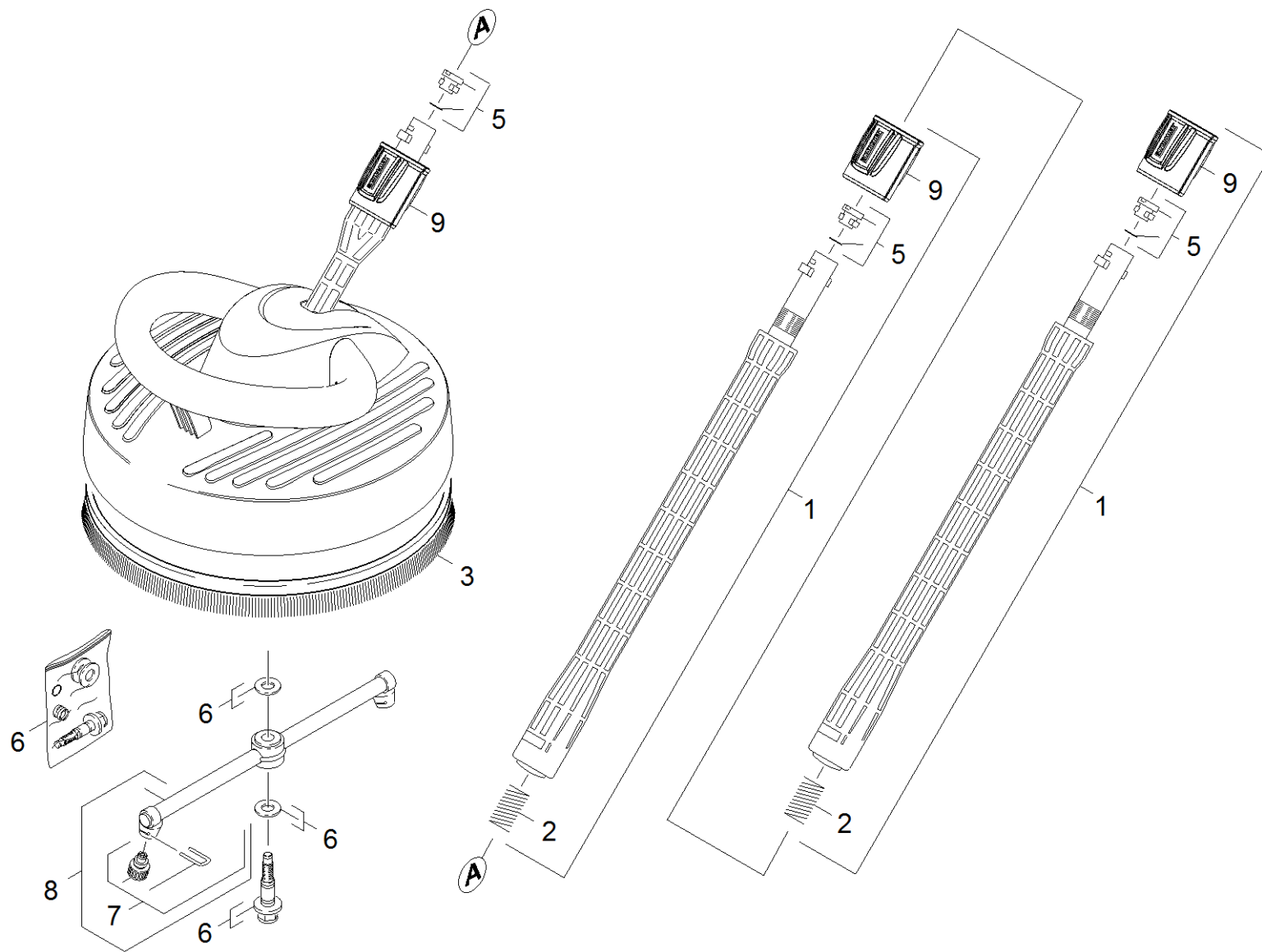

43 Surface cleaner

Rez.daļas/nodil.pakļ.daļas	Poz.	Materiāla Nr.	Nosaukums	Daudzums	Pārdoš. vienība	no sēr. Nr..	līdz sēr. Nr.
X	1	2.643-240.0	single step jet pipe	2.000	ST	0000000000	0000000000
	2	5.332-464.0	Pressure spring	2.000	ST	0000000000	0000000000
	3	6.371-086.0	Strip brush	1.000	ST	0000000000	0000000000
	5	2.640-729.0	O-Ring seal set	3.000	ST	0000000000	0000000000
	6	2.883-994.0	Spare part set	1.000	ST	0000000000	0000000000
	7	2.641-556.0	Spare part set nozzles 027	1.000	ST		
	7	9.002-410.0	Spare part nozzles Tracer 015	1.000	ST	0000000000	0000000000
	8	2.885-003.0	Spare part set rotor neutrally	1.000	ST		
	9	5.310-160.0	Nut Kaercher	3.000	ST	0000000000	0000000000

1 single step jet pipe (2.643-240.0)

Poz.	Materiāla Nr.	Nosaukums	Daudzums	Pārdoš. vienība
3	2.640-729.0	O-Ring seal set	1.000	ST
8	5.332-464.0	Pressure spring	1.000	ST
10	5.310-160.0	Nut Kaercher	1.000	ST

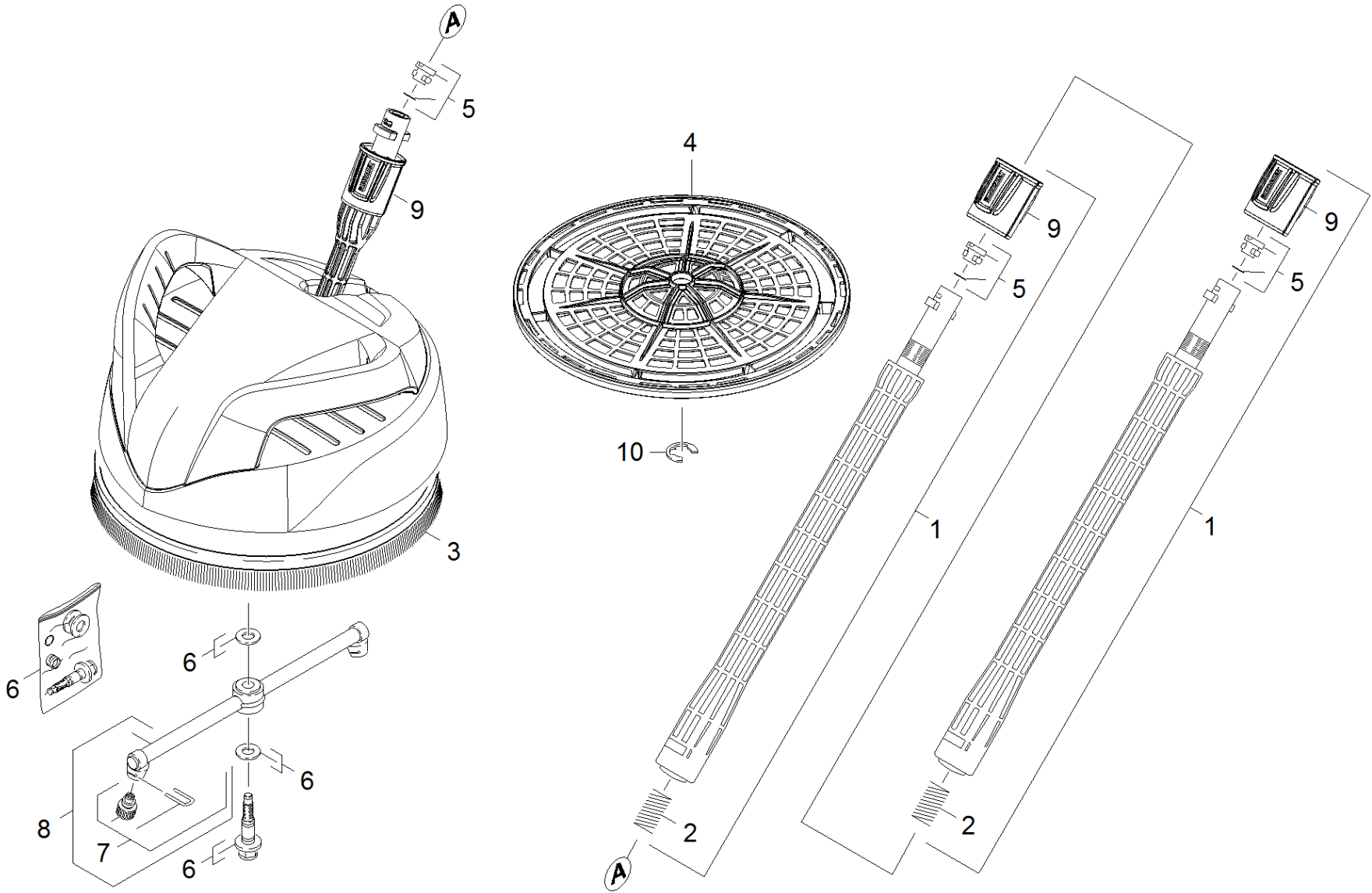

44 Surface cleaner

Rez.daļas/nodil.pakļ.dajas	Poz.	Materiāla Nr.	Nosaukums	Daudzums	Pārdoš. vienība	no sēr. Nr..	līdz sēr. Nr.
X	1	2.643-240.0	single step jet pipe	2.000	ST	0000000000	0000000000
	2	5.332-464.0	Pressure spring	2.000	ST	0000000000	0000000000
	3	6.371-086.0	Strip brush	1.000	ST	0000000000	0000000000
	4	5.394-865.0	Grate T 250 Plus	1.000	ST	0000000000	0000000000
	5	2.640-729.0	O-Ring seal set	3.000	ST	0000000000	0000000000
	6	2.883-963.0	Set of gaskets T-RACER	1.000	ST	0000000000	0000000000
X	7	2.643-338.0	Spare parts nozzles T-Racer	1.000	ST	0000000000	0000000000
	8	2.885-182.0	Spare part set rotor T 250 plus	1.000	ST	0000000000	0000000000
	9	5.310-160.0	Nut Kaercher	3.000	ST		
	10	7.343-206.0	Sprostpaplāksne 12-2.1030 DIN 6799	1.000	ST		

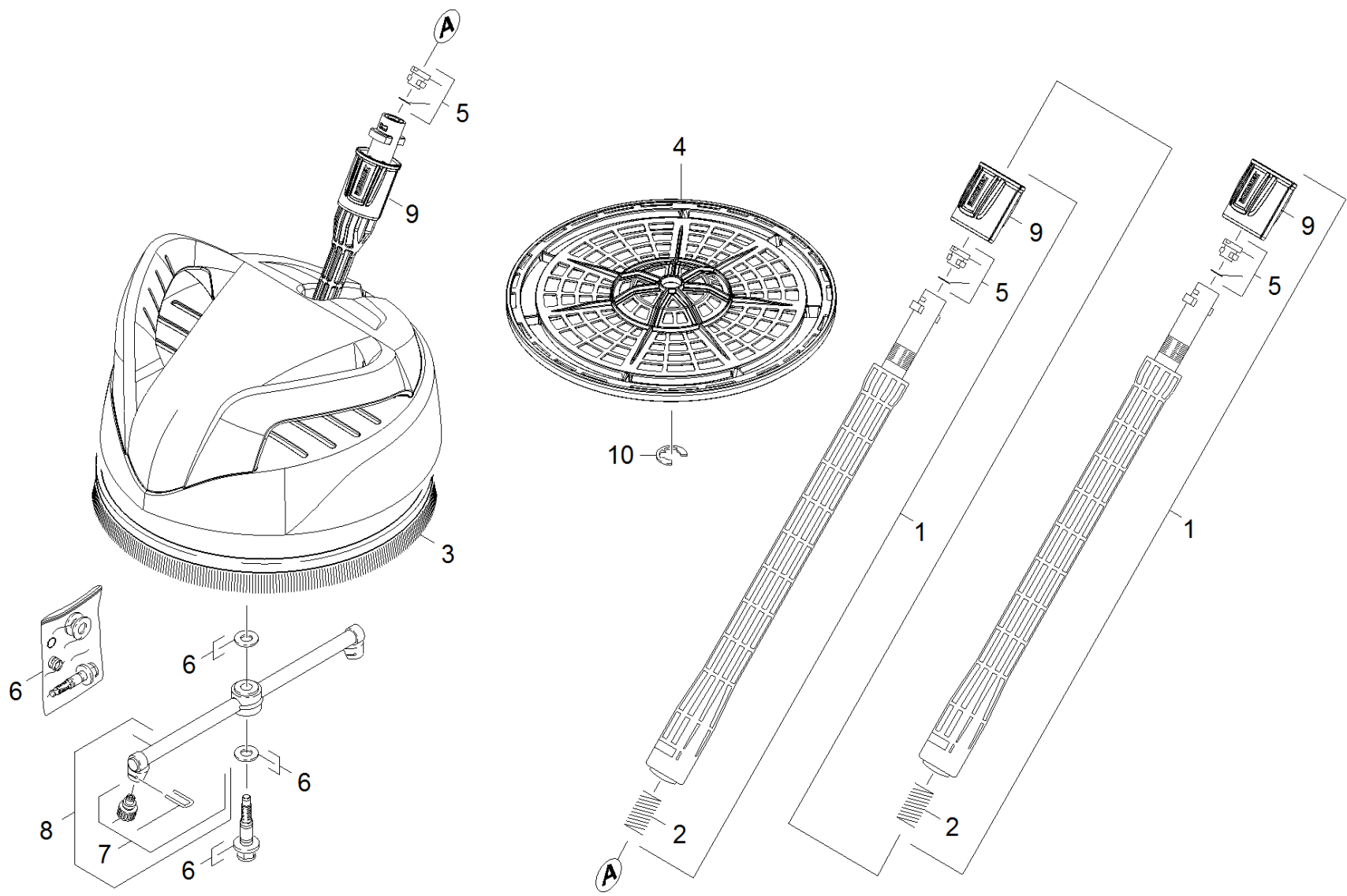





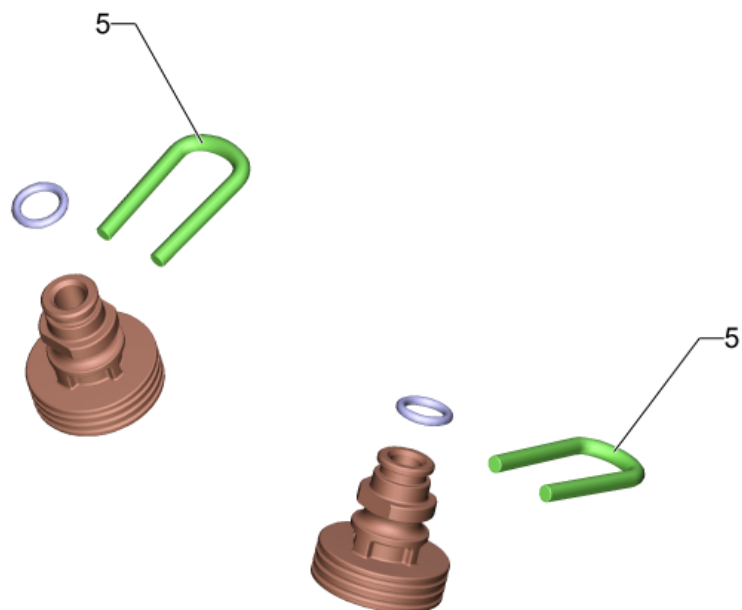



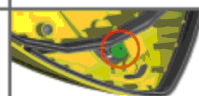

1 single step jet pipe (2.643-240.0)



Poz.	Materiāla Nr.	Nosaukums	Daudzums	Pārdoš. vienība
3	2.640-729.0	O-Ring seal set	1.000	ST
8	5.332-464.0	Pressure spring	1.000	ST
10	5.310-160.0	Nut Kaercher	1.000	ST



7 Spare parts nozzles T-Racer (2.643-338.0)

T 50, T 70, T 80, T 100 T 150, T 200, T 250, T 300, T 400, T 450, T 550	K 2 - K 5		
	K 6 - K 7		
T 400, T 450 T 550			
T 200, T 250	K 6 - K 7		
T 350 Gas			

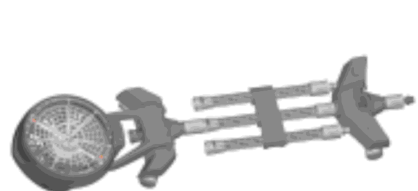
	K 3 - K 5	
	K 6 - K 7	

	K 2	
	K 3 - K 5	

7 Spare parts nozzles T-Racer (2.643-338.0)

Rez.daļas/nodil.pakļ.daļas	Poz.	Materiāla Nr.	Nosaukums	Daudzums	Pārdoš. vienība	Daž. informācija
X-X	1	4.764-155.0	Nozzle complete 15015	1.000	ST	<13 MPa (<130 bar)
Pozīcijas teksts: 015						
X-X	2	4.764-156.0	Nozzle complete 15020	1.000	ST	13 MPa (130 bar) - 16 MPa (160 bar)
Pozīcijas teksts: 020						
	3		Nozzle complete 15027	1.000	ST	
Pozīcijas teksts: 027						
	4	4.764-190.0	Nozzle kpl. 75047	1.000	ST	
Pozīcijas teksts: 047						
	5	5.037-151.0	Clamp	2.000	ST	

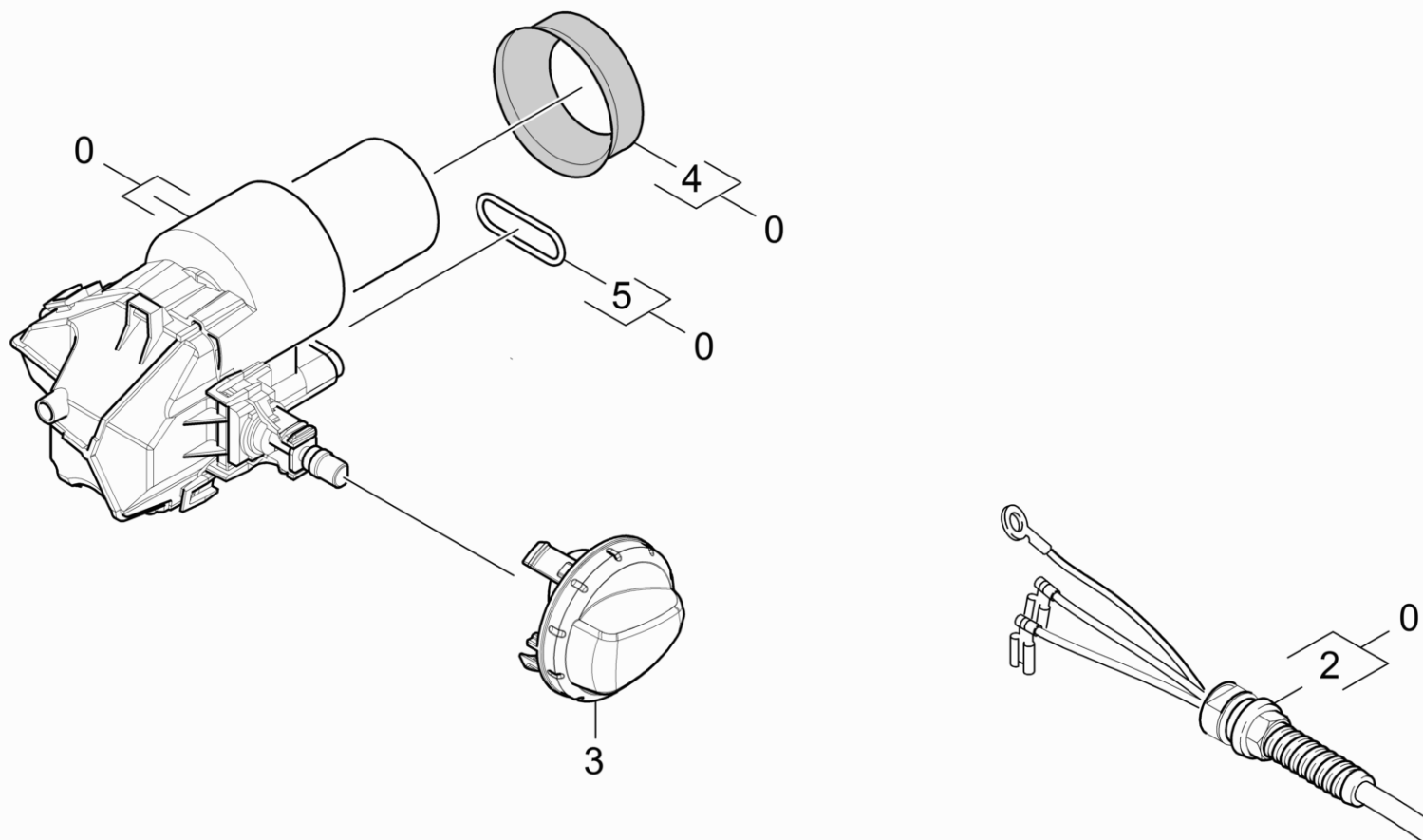

50 Electric box

Poz.	Materiāla Nr.	Nosaukums	Daudzums	Pārdoš. vienība
0	9.002-051.0	E-box K5 GB Modular spare	1.000	ST
Pozīcijas teksts: 1.181-202.0 /-212.0				
0	9.002-050.0	E-box EU K5 Modular spare	1.000	ST
Pozīcijas teksts: 1.181-200.0 /-201.0 /-203.0 /-209.0/-213.0 /-214.0 /-217.0				
0	9.001-770.0	Electric box spare part	1.000	ST
Pozīcijas teksts: 1.181-204.0 /-205.0				
2	9.084-290.0	Cable with plug 3G1 *CH	1.000	ST
Pozīcijas teksts: 1.181-204.0 /-205.0				
2	9.084-144.0	Cable with plug	1.000	ST
Pozīcijas teksts: 1.181-202.0 /-212.0				
2	9.084-139.0	Kabelis ar kontaktdakšu *EU	1.000	ST
Pozīcijas teksts: 1.181-200.0 /-201.0 /-203.0 /-209.0/-213.0 /-214.0 /-217.0				
3	9.037-693.0	cover modular	1.000	ST
4	9.080-465.0	Blīvgredzena kondensators d.45, 70 Shore	1.000	ST
5	9.081-417.0	Blīvgredzens d.20 x 2	1.000	ST