

# K 7 Full Control Service Manual



<b>Preface</b>	<b>4</b>
<b>Safety instructions</b>	<b>4</b>
Hazard levels	4
<b>Description in this service manual</b>	<b>5</b>
Service groups	5
Functional group structure	5
Textual description	5
<b>Technical Features</b>	<b>6</b>
Intended use	6
Field of application	6
Safety installations	6
Lock trigger gun	6
Overflow valve with pressure switch	6
Type plate	7
<b>AB Service group setup</b>	<b>8</b>
010 Safety information	8
General	8
020 Overview	8
030 Function	9
040 Service activities	9
ABST Uninstall / install hose reel	9
ABGH Uninstalling / installing casing	10
ABRD Uninstall / install wheels	10
ABSB Uninstall / install push handle	11
050 Maintenance and inspection	11
060 Error diagnosis	11
070 Peculiarities/ others	11
<b>AE Service group pump</b>	<b>12</b>
010 Safety information	12
General	12
020 Overview	12
030 Function	13
040 Service activities	14
AERR Uninstall / install backflow valve detergent	14
AESG Uninstall / install valve gear casing	15
AEUV Uninstalling / installing the overflow valve	15
AEZK Uninstall / install cylinder head	16
AEVT Uninstall / install valves and seals	16
AEKF Uninstall / install piston guide	18
AETS Uninstall / install swash plate	19
AEKL Uninstall / install ball bearing and grooved ring	20
AEWA Uninstall / install outer jacket of water channel	20
050 Maintenance and inspection	20
060 Error diagnosis	20
070 Peculiarities/ others	20
<b>AH Service group electrics</b>	<b>21</b>
010 Safety information	21
General	21
020 Overview	21
030 Function	22
040 Service activities	22
AHEK Uninstall / install electrical box	22
AHNK Uninstalling / installing mains connection	23

050 Maintenance and inspection	23
060 Error diagnosis	23
070 Peculiarities/ others	23
<b>Circuit diagram</b>	<b>24</b>
<b>Special tools</b>	<b>25</b>
<b>Technical specifications</b>	<b>27</b>

## Preface

Good service work requires extensive and practice-oriented training as well as well-structured training materials. Hence we offer regular basic and advanced training programmes covering the entire product range for all service engineers.

In addition to this, we also prepare service manuals for important appliances - these can be initially used as instruction guides and later on as reference guides.

Apart from this, we also regular information about product enhancements and their servicing.

If you should require supplements, have corrections or questions regarding this document, please address these citing the following subject to:

*international-service@de.kaercher.com*

Subject:	<b>Fall 120851</b>
----------	--------------------

The responsible product specialist will take care of your issue.

**Copying and duplication of texts and diagrams as well as third-party access to this information is permitted only with the explicit permission of the company:**

**Alfred Kärcher GmbH & Co. KG**

**P O Box 160**

**D -71349 Winnenden**

**www.kaercher.com**

## Safety instructions

Service and maintenance tasks may only be performed by qualified and specially trained specialists.

**Observe safety information in the chapters!**

**⚠ DANGER**

*Prior to all work on the appliance, switch off the appliance and pull the power plug.*

**⚠ CAUTION**

*Risk of damage by electrostatic discharge (ESD)! Take suitable measures for discharging electrostatic charge prior to performing work on the appliance electronics.*

## Hazard levels

**⚠ DANGER**

*For an immediate danger which can lead to severe injuries or death.*

**⚠ WARNING**

*For a possibly dangerous situation which could lead to severe injuries or death.*

**⚠ CAUTION**

*For a possibly dangerous situation which can lead to minor injuries or property damage.*

**ATTENTION**

*Pointer to a possibly dangerous situation, which can lead to property damage.*

**Note**

Indicates useful tips and important information.

## Description in this service manual

### Service groups

**Example:**

Install/uninstall ANRA wheel axle

AN	RA	Install/uninstall wheel axle
Service group	Component	Activity

Observe the allocation of service groups to the appliance components in the overview diagram in Chapter "Overview over the service and functional groups".

### Functional group structure

<b>010</b>	Safety instructions
<b>020</b>	Overview
<b>030</b>	Function
<b>040</b>	Service activities
<b>050</b>	Maintenance and inspection
<b>060</b>	Error diagnosis
<b>070</b>	Peculiarities/ others
<b>080 - 100</b>	Not assigned

### Textual description

→ Instruction

■ *Preparatory operations*

1

2 Key numerical

A

B Key alphanumerical

– Enumeration / General list

⚠ **Safety note**

*Pointer to hazards, sources of errors.*

## Technical Features

- 3 piston axial pump with stainless steel piston
- Pressure relief system
- Electric motor with thermal motor protection switch.
- Retractable push handle
- Carrying handle
- Additional spray lance holder with fixation for transportation

## Intended use

This high pressure cleaner is designed for domestic use only.

- for cleaning machines, vehicles, buildings, tools, facades, terraces, gardening tools, etc. by means of a high-pressure water jet (if necessary, with additional cleaning agents).
- with accessories, replacement parts and cleaning agents approved by KÄRCHER. Please observe the information accompanying the cleaning agents.

## Field of application

This service manual describes the appliance family:

- K 7 Full Control

## Safety installations

Safety devices serve to protect the user and must not be rendered in operational or their functions bypassed.

**Observe safety information in the chapters!**

## Lock trigger gun

This lock locks the lever of the trigger gun and prevents the inadvertent start of the appliance.

## Overflow valve with pressure switch

The overflow valve prevents the permissible working pressure from being exceeded.

If the lever on the trigger gun is released the pressure switch turns off the pump, the high pressure jet is stopped. If the lever is pulled the pump is turned on again.

## Type plate



The type plate is located at the bottom of the appliance.

- 1 Serial number
- 2 IP rating/ protection class
- 3 Sound power level  $L_{WA}$
- 4 Bar code. Contains part and serial number.
- 5 Address of manufacturer
- 6 Max. flow rate
- 7 Specifications
- 8 Part number
- 9 Appliance description

## AB Service group setup

### 010 Safety information

#### General

Observe general safety information!

Service and maintenance tasks may only be performed by qualified and specially trained specialists.

#### **⚠ DANGER**

- Switch off the appliance and, in case of appliances connected to the mains, pull out the power cord before cleaning and performing any maintenance tasks on the machine.
- Maintenance work may only be carried out by approved customer service outlets or experts in this field who are familiar with the respective safety regulations.
- To avoid risks, all repairs and replacement of spare parts may only be carried out by the authorised customer service personnel.
- Only use accessories and spare parts which have been approved by the manufacturer. The exclusive use of original accessories and original spare parts ensures

*that the appliance can be operated safely and trouble free.*

- *Allow the appliance to cool down prior to performing service tasks.*

### 020 Overview



*ABGH Uninstalling / installing casing*

*ABRD Uninstall / install wheels*

*ABSB Uninstall / install push handle*

*ABST Uninstall / install hose reel*



## 030 Function

No special functional characteristics.

## 040 Service activities

### Note

Unless otherwise described, the installation takes place in reverse order.

### ABST Uninstall / install hose reel

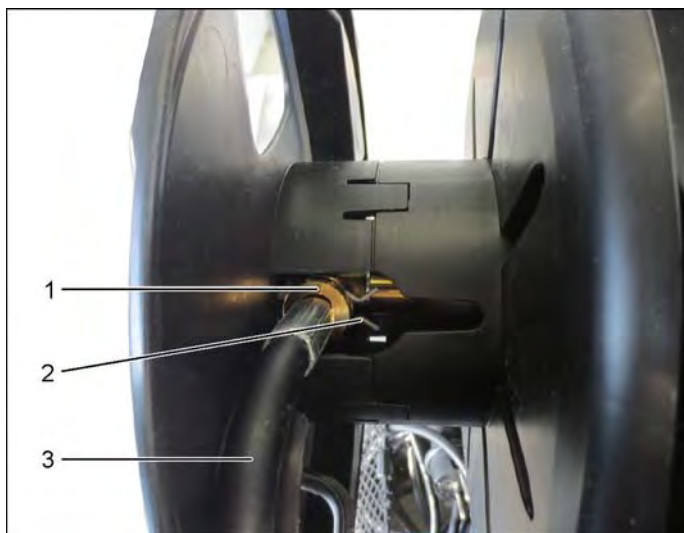

- 1 Hollow shaft
- 2 Safety clip
- 3 High pressure hose

- ➔ Completely roll off the high-pressure hose from the hose drum.
- ➔ Pull out the safety clip.
- ➔ Remove the high pressure hose from the hollow shaft.



- 1 Hose drum
- 2 Safety disc

- ➔ Remove the safety disc.
- ➔ Pull off hose reel casing shells towards the front.



- 1 Bearings  
Hose drum
- 2 Safety disc
- 3 Rotating grommet

- ➔ Remove the safety disc.
- ➔ Pull off rotating grommet.
- ➔ Pull off hose reel bearings.

### Note

Check O-rings for damage.

## ABGH Uninstalling / installing casing

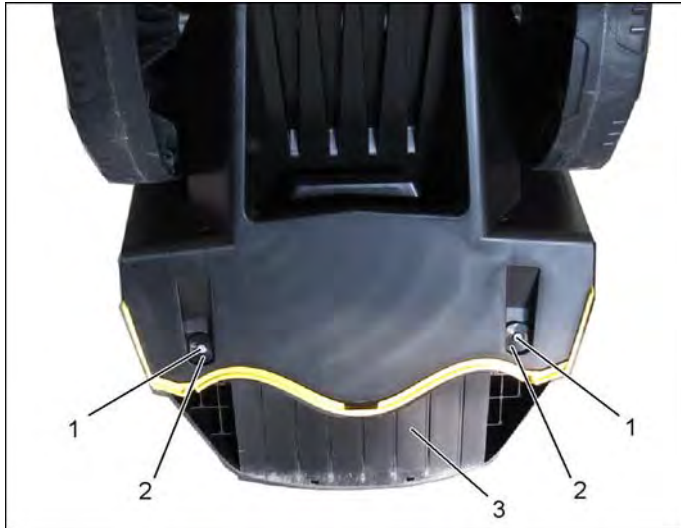

### ■ ABST Uninstall / install hose reel

- 1 Screws
- 2 Base bolts
- 3 Base

- Unscrew the screws.
- Pull out the bolts of the base.
- Take off the base.



- 1 Screws
- 2 Casing

- Unscrew the screws.
- Remove the housing.

### Note

Use special tools.  
Screwdriver bit T15  
6.815-150.0

Torques	Nm
Screws	1,2...1,9

## ABRD Uninstall / install wheels

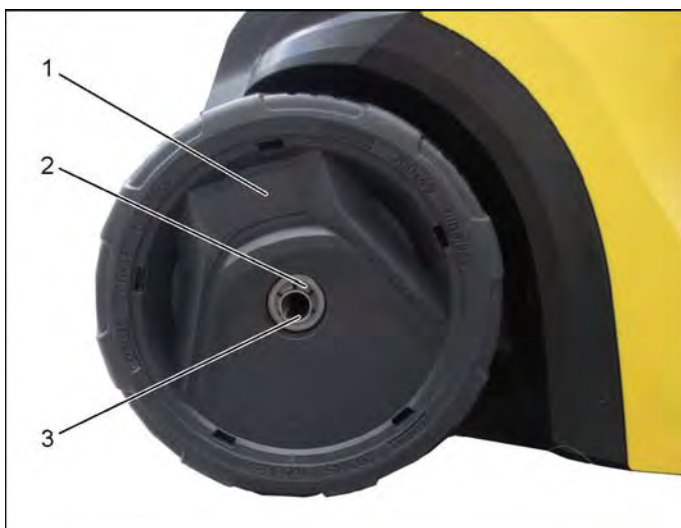

- 1 Wheel
- 2 Safety disc
- 3 Axle

- Remove the wheel cover.
- Remove the safety disc.
- Remove the wheel.

### Note

The lock washer is destroyed upon removal.

## ABSB Uninstall / install push handle

### ■ ABGH Uninstalling / installing casing

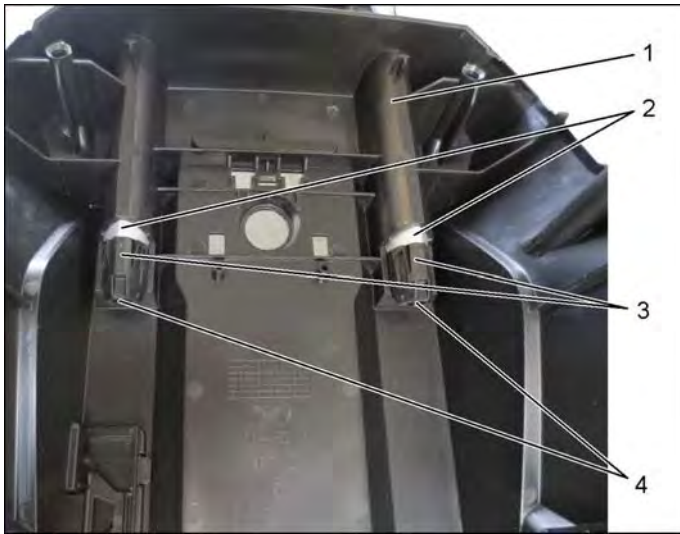

- 1 Casing
- 2 Push handle
- 3 End piece
- 4 Screws

- ➔ Pull the push handle upward.
- ➔ Unscrew the screws.
- ➔ Pull off end pieces.
- ➔ Remove the push handle.

## 050 Maintenance and inspection

Service group does not contain any maintenance and inspection points.

## 060 Error diagnosis

The service group does not contain any error diagnosis.

## 070 Peculiarities/ others

The service group does not contain any peculiarities.

## AE Service group pump

### 010 Safety information

#### General

Observe general safety information!

Service and maintenance tasks may only be performed by qualified and specially trained specialists.

#### **⚠ DANGER**

- Switch off the appliance and, in case of appliances connected to the mains, pull out the power cord before cleaning and performing any maintenance tasks on the machine.
- Maintenance work may only be carried out by approved customer service outlets or experts in this field who are familiar with the respective safety regulations.
- To avoid risks, all repairs and replacement of spare parts may only be carried out by the authorised customer service personnel.
- Only use accessories and spare parts which have been approved by the manufacturer. The exclusive use of

*original accessories and original spare parts ensures that the appliance can be operated safely and trouble free.*

- Allow the appliance to cool down prior to performing service tasks.

### 020 Overview

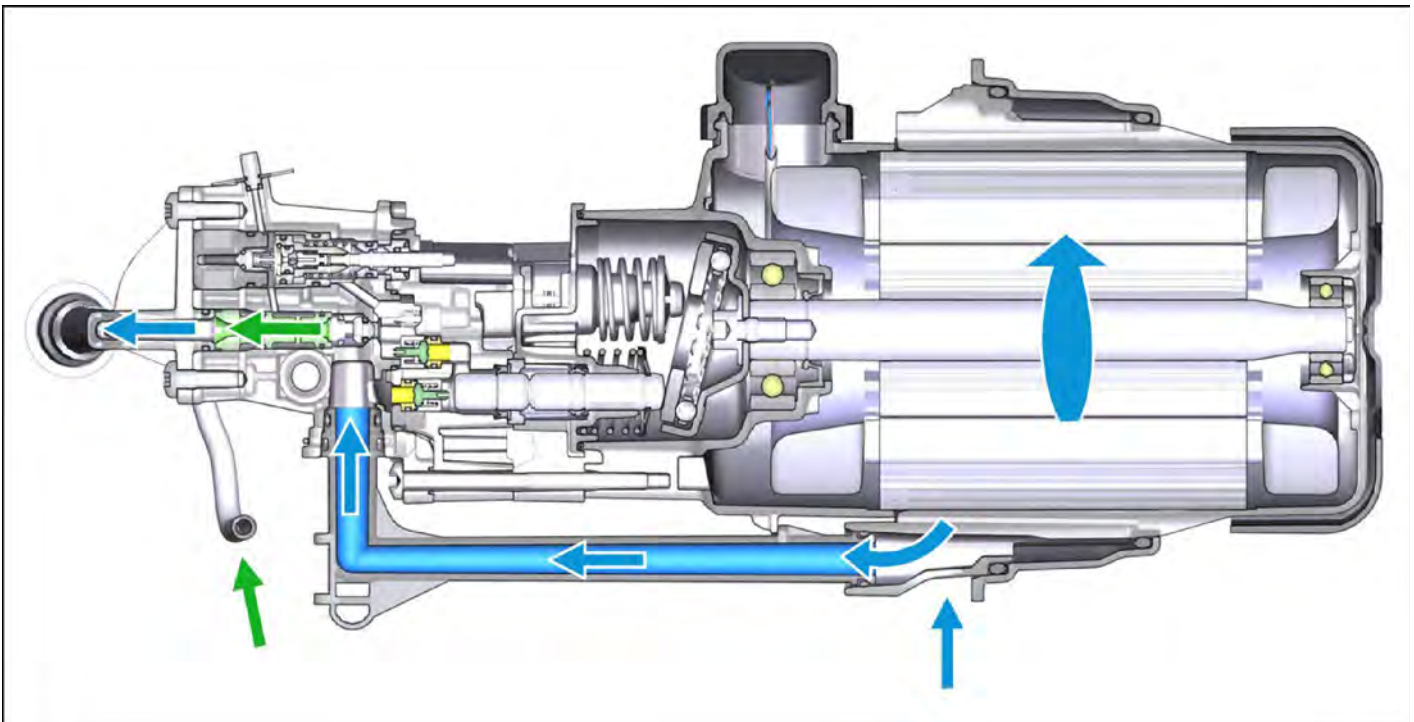

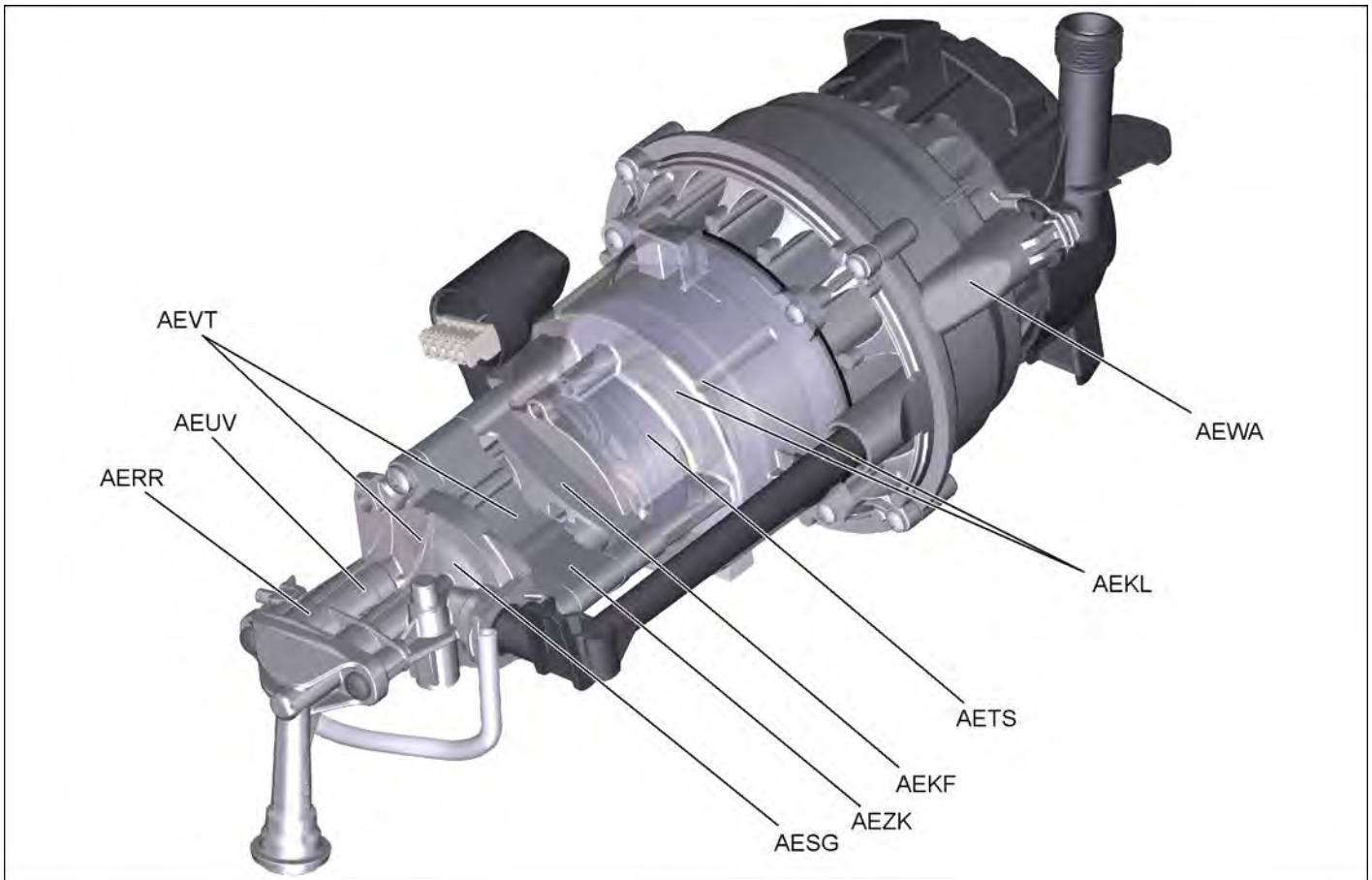

- AESG Uninstall / install valve gear casing*
- AEZK Uninstall / install cylinder head*
- AEKF Uninstall / install piston guide*
- AEVT Uninstall / install valves and seals*
- AETS Uninstall / install swash plate*
- AEKL Uninstall / install ball bearing and grooved ring*
- AERR Uninstall / install backflow valve detergent*
- AEUV Uninstalling / installing the overflow valve*
- AEWA Uninstall / install outer jacket of water channel*

### **030 Function**

No special functional characteristics.

## 040 Service activities

### Note

Unless otherwise described, the installation takes place in reverse order.

### AERR Uninstall / install backflow valve detergent



- *ABGH Uninstalling / installing casing*
- *Remove the pump kit.*

- 1 High-pressure outlet
- 2 Screws

- ➔ Unscrew the screws.
- ➔ Remove high-pressure outlet.



- 1 Chemical valve

- ➔ Remove chemical valve.

### Installation information

Check O-ring for damage.

Torques	Nm
Screw M6	8...9

## AESG Uninstall / install valve gear casing

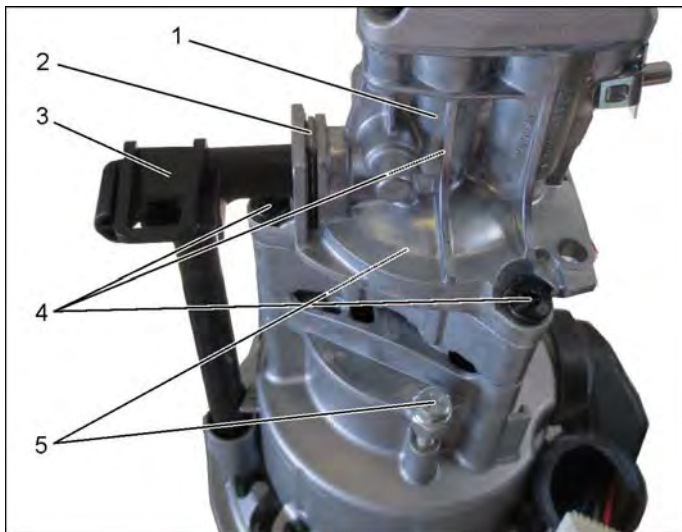

- *ABGH Uninstalling / installing casing*
- *Remove the pump kit.*
- *AHEK Uninstall / install electrical box*

- 1 Valve gear casing
- 2 Clip
- 3 Pipe return
- 4 Screws
- 5 Pressure pad

- ➔ Remove the clip.
- ➔ Remove pipe return.
- ➔ Hold down piston guide.
- ➔ Remove the screws.
- ➔ Take off the valve gear casing.

Torques	Nm
Screw M6	9...11

## AEUV Uninstalling / installing the overflow valve

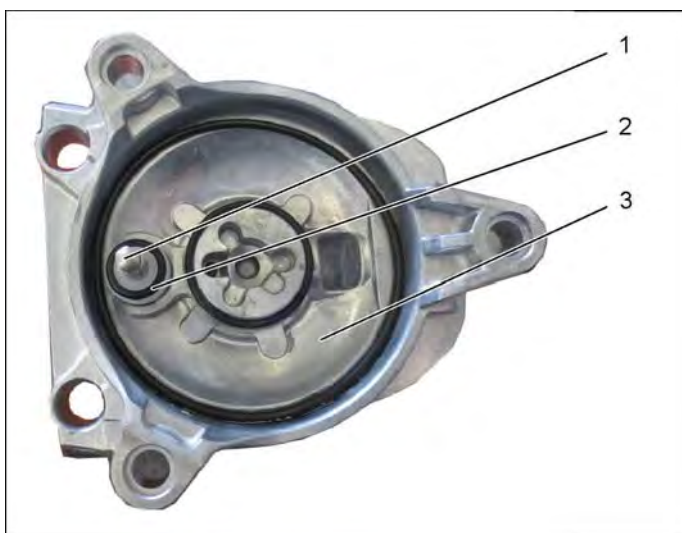

- *AESG Uninstall / install valve gear casing*

- 1 Overflow
- 2 O ring
- 3 Valve gear casing

- ➔ Push the overflow valve down out of the valve gear casing.

### Note

Check the O-ring. Replace if necessary.

### Installation information

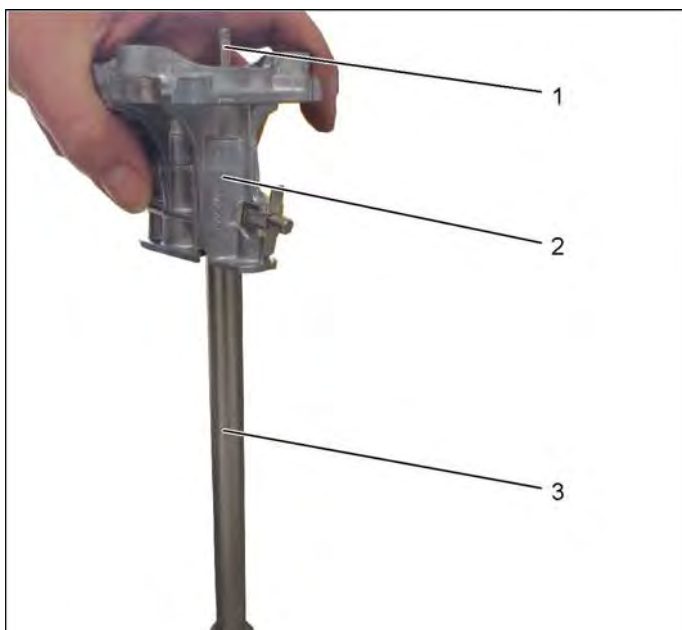

- 1 Overflow
- 2 Valve gear casing
- 3 Tool  
e.g.  
Extension piece

- ➔ Press overflow valve with tool into the retainer.

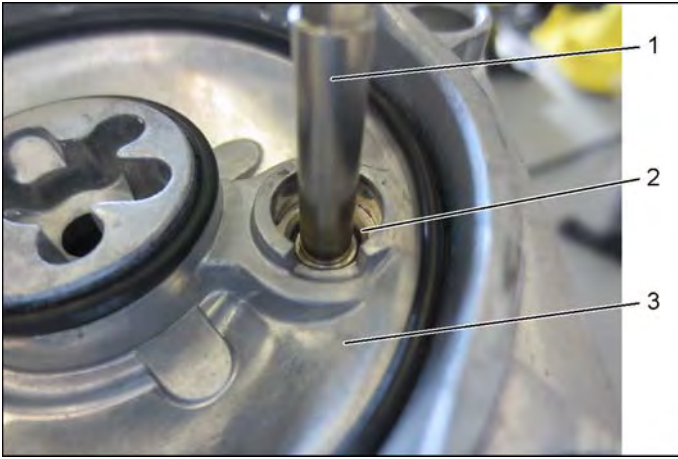

- 1 Overflow
- 2 Intake
- 3 Valve gear casing

**Installation information**

Insert the overflow valve up into the retainer up to the upper stop.

**AEZK Uninstall / install cylinder head**

The procedure conforms to the task:

- *AESG Uninstall / install valve gear casing*

**AEVT Uninstall / install valves and seals**

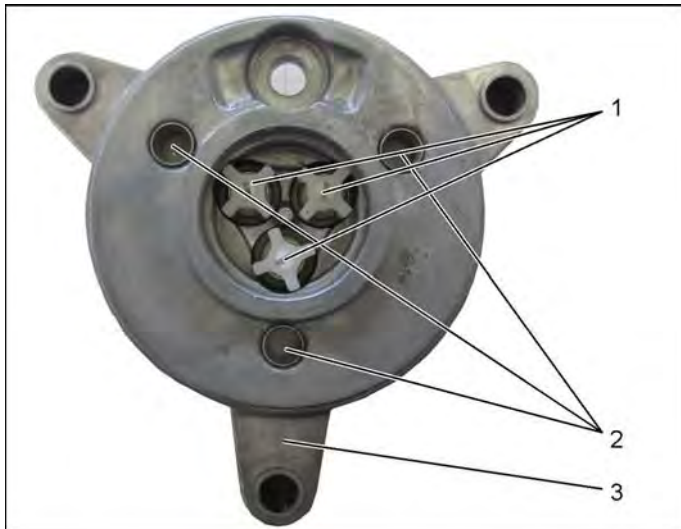

- *ABGH Uninstalling / installing casing*
- *Remove the pump kit.*
- *AESG Uninstall / install valve gear casing*

- 1 Pressure valve
- 2 Suction valve
- 3 Cylinder head

- ➔ Replace valves and seals as necessary.
- ➔ Pull out the upper parts of the pressure valve using valve pliers.



- ➔ Lightly grease the O-rings.
- ➔ Insert new pressure valves into the pump head.





**Note**

- ➔ Drive the suction valves out of the cylinder head using a drift punch (Ø 6.0...6.4 mm).
- ➔ Lightly grease the O-rings on the suction valves.

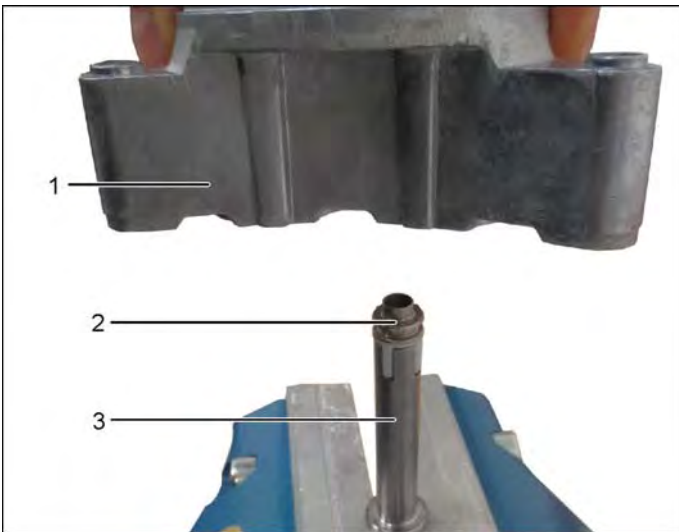

- 1 Cylinder head
- 2 Suction valve
- 3 Valve retainer

- ➔ Insert new suction valves into the cylinder head.
- ➔ Support the cage side of the suction valve by means of the valve retainer (special tool 2.901-049.0).

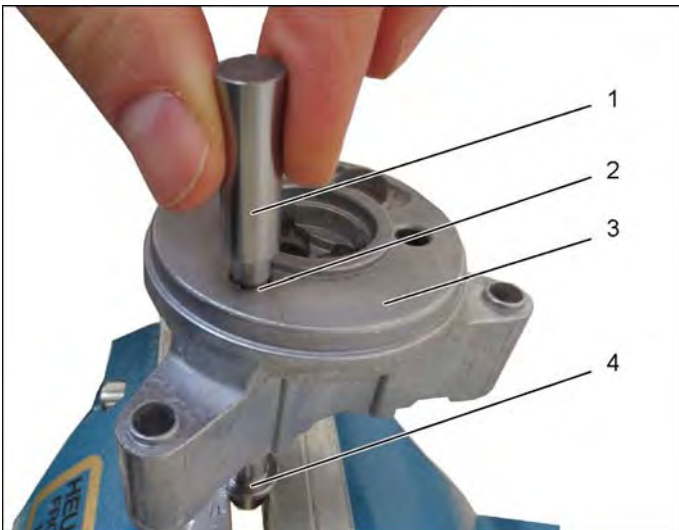

- 1 Drive mandrel
- 2 Suction valve
- 3 Cylinder head
- 4 Valve retainer

- ➔ Flare the opposite side by means of the drive-in mandrel (special tool 2.901-049.0).

**NOTE**

If there is no possibility to flare the valves, the complete cylinder head can be ordered and replaced as a spare part.

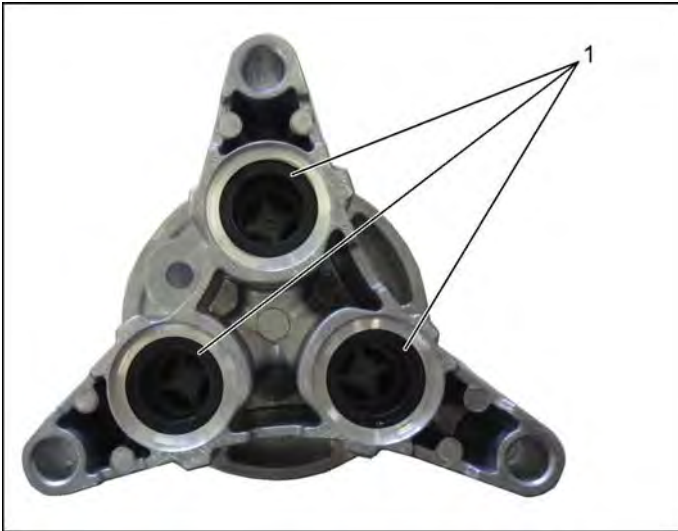

1 Nut rings

- ➔ Check nut rings, replace if necessary.
- ➔ Do not cant the grooved ring.
- ➔ Insert nut rings using the installation mandrel.

**AEKF Uninstall / install piston guide**

■ *AESG Uninstall / install valve gear casing*

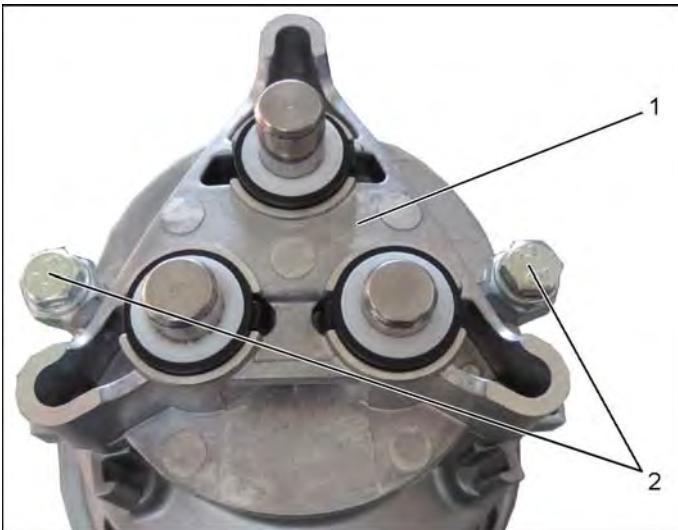

1 Piston guide  
2 Screws  
Pressure pad

- ➔ Unscrew the screws.
- ➔ Remove the piston guide and the piston.

⚠ **CAUTION**

Piston guide is tensioned by piston springs.

Pay attention to the correct fitting position during reinstallation.



1 Safety disc  
2 Piston  
3 Springs  
4 Piston guide

- ➔ Check piston for wear.
- ➔ Check springs.

Observe piston condition diagram.

In case of a missing or poor condition diagram, the turning of the piston is not guaranteed.

## AETS Uninstall / install swash plate

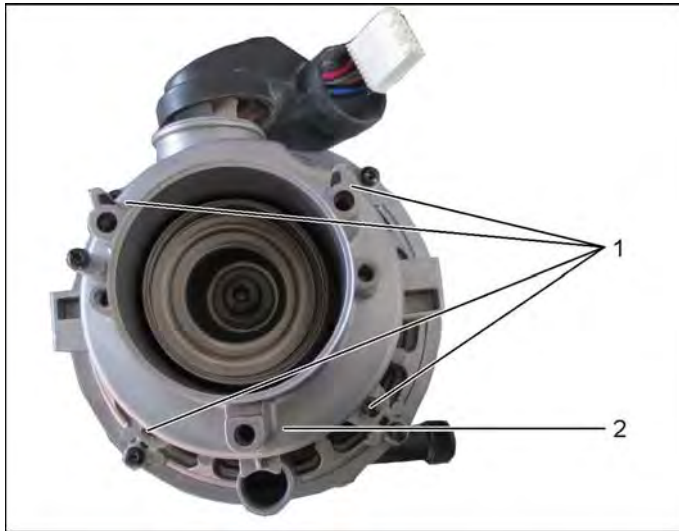

### ■ AEKF Uninstall / install piston guide

- 1 Motor flange
- 2 Screws

- ➔ Drain and collect the oil.
- ➔ Unscrew the screws.
- ➔ Remove motor flange.

#### Note

The pressure disc and ball bearing are loosely supported.

Torques	Nm
Screw M5	5,5...7,5

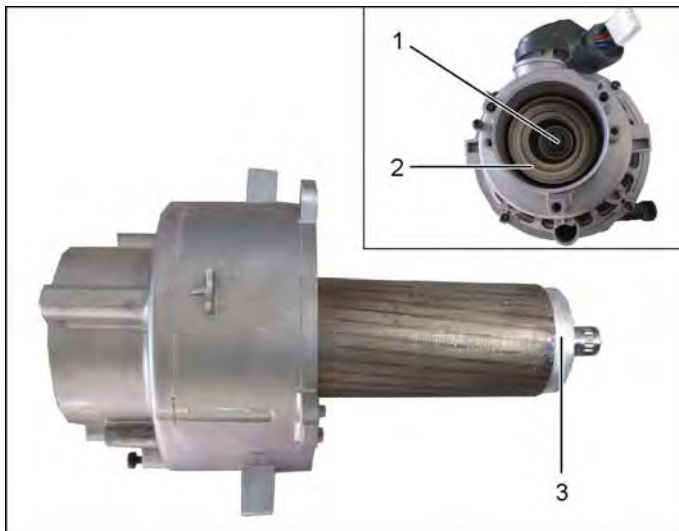

- 1 Screw
- 2 Swash plate
- 3 Rotor

- ➔ Fixate rotor.
- ➔ Loosen screws.
- ➔ Remove swash plate.

Amount of oil	ml
15W40	120

Torques	Nm
Screw M8	18...22

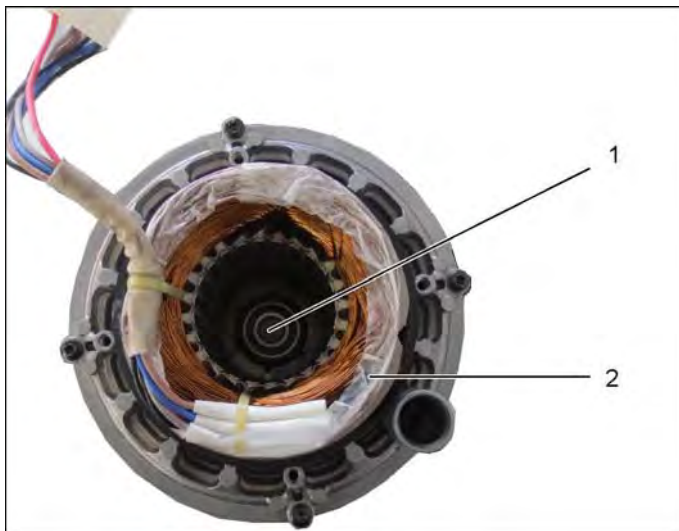

- 1 Ball bearing
- 2 Motor

#### Installation information

Rotor must sit as far into the ball bearing as possible.

## AEKL Uninstall / install ball bearing and grooved ring



### ■ AETS Uninstall / install swash plate

1 Motor flange

➔ Lay down the motor flange.

➔ Tap out the grooved ring and the ball bearing.

### Installation information

When inserting the grooved ring, lay the motor flange down flat.

Do not cant the grooved ring.

When pressing in the ball bearing, lay the motor flange down flat.

## AEWA Uninstall / install outer jacket of water channel



### ■ ABGH Uninstalling / installing casing

### ■ Remove the pump kit.

1 Outer jacket of water channel

2 Screws

➔ Loosen screws.

➔ Remove outer jacket of water channel towards the bottom.

### Installation information

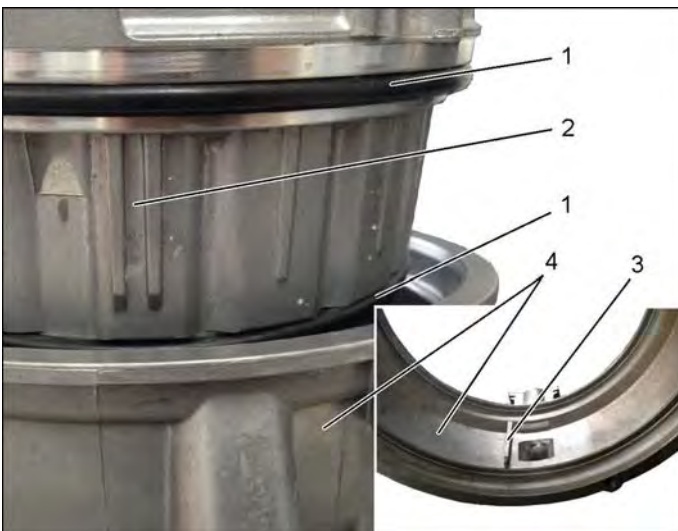

1 O ring

2 Intake

3 Web

4 Outer jacket of water channel

Check the O-ring. Replace if necessary.

Mind the installation position.

Web must be inserted as far as possible.

## 050 Maintenance and inspection

Service group does not contain any maintenance and inspection points.

## 060 Error diagnosis

The service group does not contain any error diagnosis.

## 070 Peculiarities/ others

The service group does not contain any peculiarities.

## AH Service group electrics

### 010 Safety information

#### General

Observe general safety information!

Service and maintenance tasks may only be performed by qualified and specially trained specialists.

#### **⚠ DANGER**

- Switch off the appliance and, in case of appliances connected to the mains, pull out the power cord before cleaning and performing any maintenance tasks on the machine.
- Maintenance work may only be carried out by approved customer service outlets or experts in this field who are familiar with the respective safety regulations.
- To avoid risks, all repairs and replacement of spare parts may only be carried out by the authorised customer service personnel.
- Only use accessories and spare parts which have been approved by the manufacturer. The exclusive use of original accessories and original spare parts ensures

*that the appliance can be operated safely and trouble free.*

- *Allow the appliance to cool down prior to performing service tasks.*

### 020 Overview

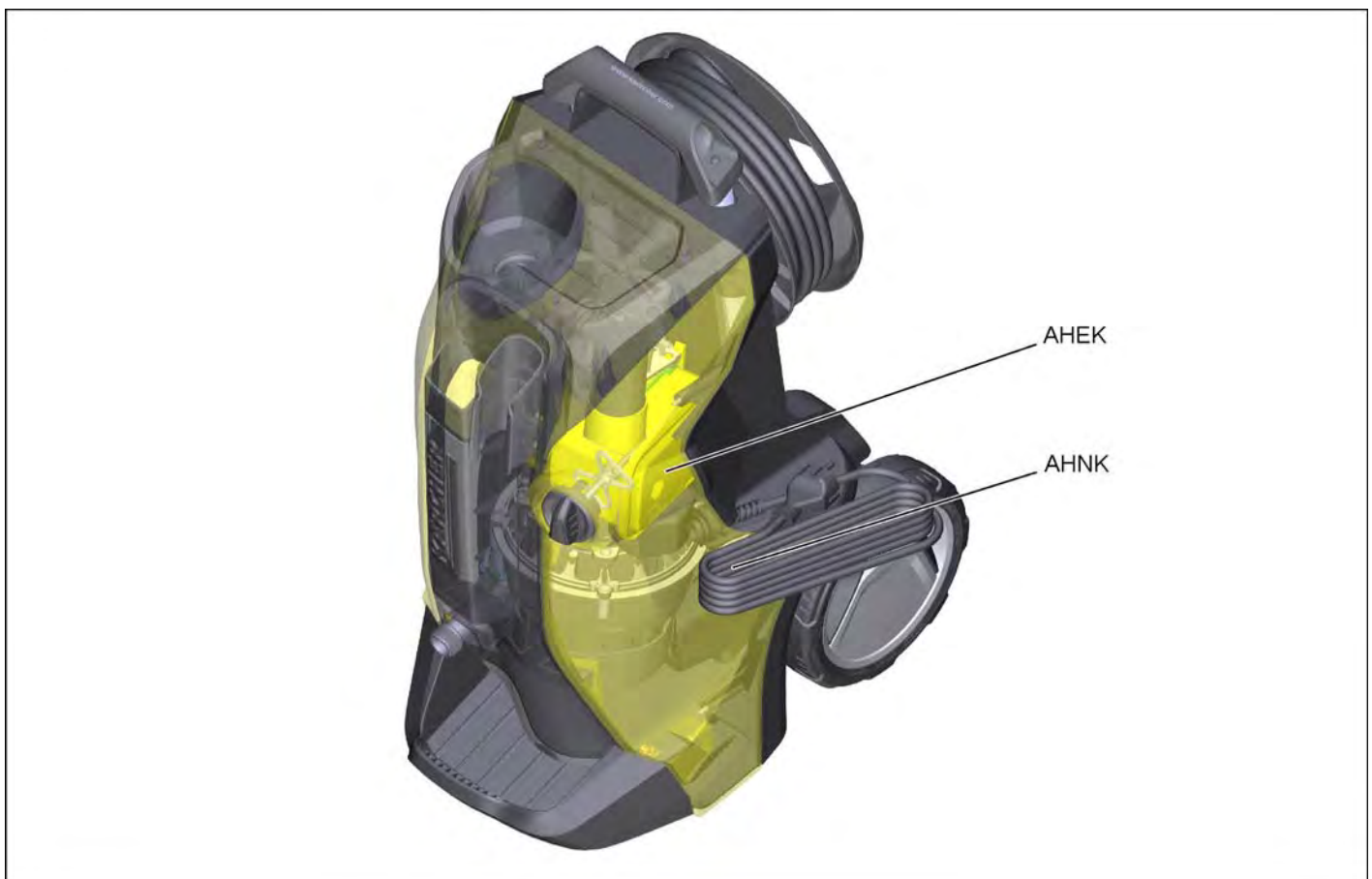

AHEK Uninstall / install electrical box

AHNK Uninstalling / installing mains connection

## 030 Function

No special functional characteristics.

## 040 Service activities

### Note

Unless otherwise described, the installation takes place in reverse order.

### AHEK Uninstall / install electrical box

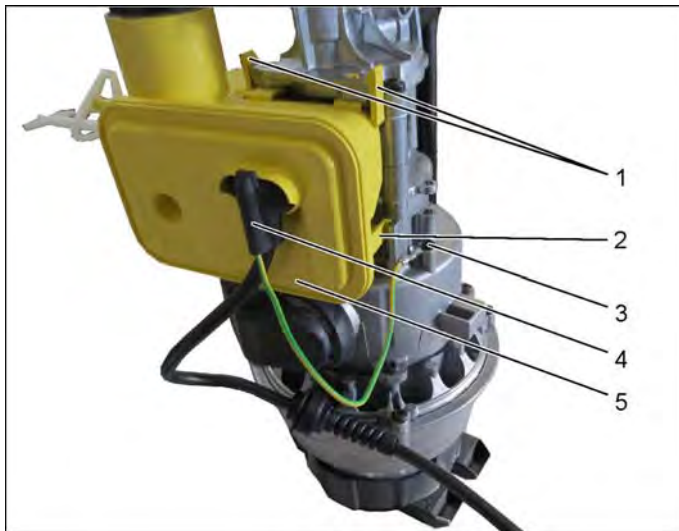

- ABGH Uninstalling / installing casing
- *Remove the pump kit.*

- 1 Retaining clip  
Up
- 2 Retaining clip  
Down
- 3 Screw
- 4 Mains cable
- 5 Electronics system

- ➔ Loosen screws.
- ➔ Disconnect the mains connection cable.
- ➔ Push the upper clip outwards.
- ➔ Push the electrical box downwards.
- ➔ Push the lower clip inwards.
- ➔ Remove the electrical box.



- 1 Plug
- 2 Electrical box connection

- ➔ Remove electrical box connection.
- ➔ Remove the plug.

## AHNK Uninstalling / installing mains connection

### ■ ABGH Uninstalling / installing casing

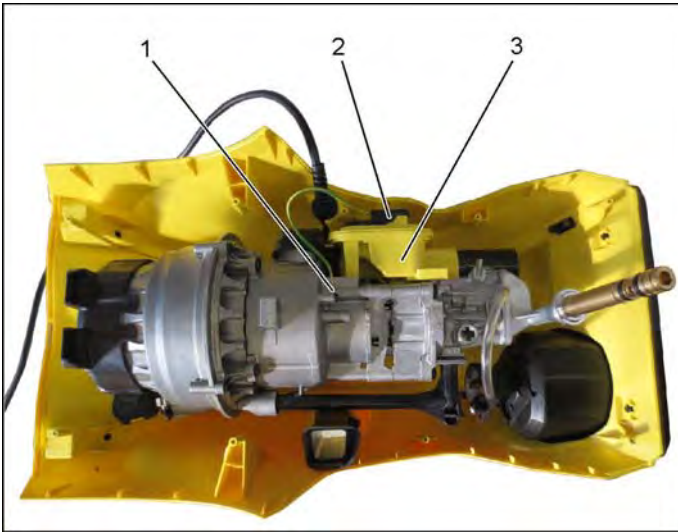

- 1 Screw
- 2 Mains connection
- 3 Electronics system

- ➔ Loosen screws.
- ➔ Pull out the mains connection.

## 050 Maintenance and inspection

Service group does not contain any maintenance and inspection points.

## 060 Error diagnosis

The service group does not contain any error diagnosis.

## 070 Peculiarities/ others

The service group does not contain any peculiarities.

## Circuit diagram

When working on the device, please always use the current circuit diagram in DISIS.

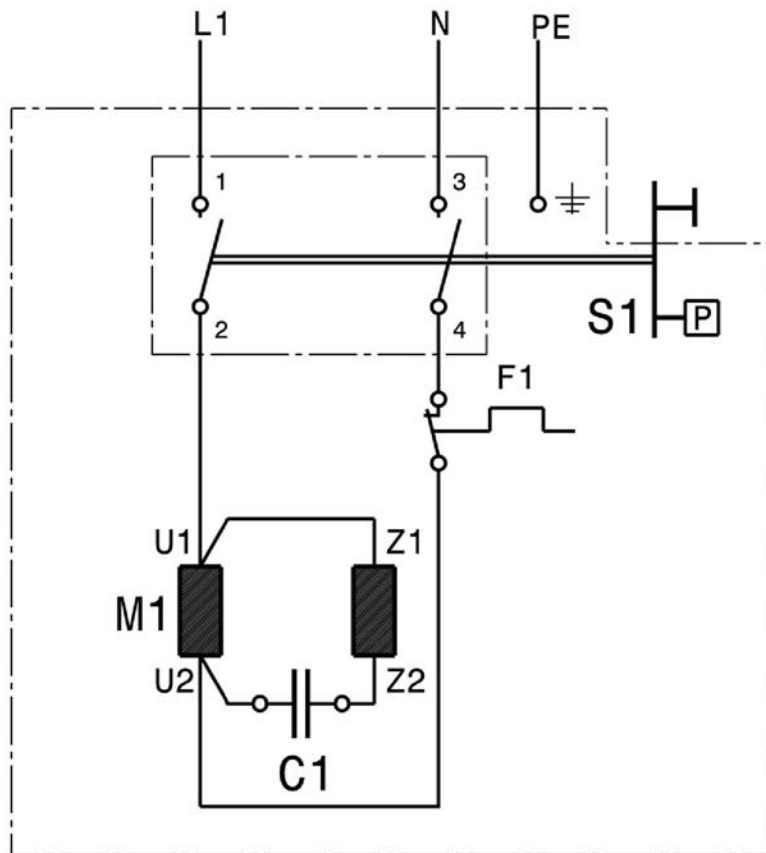

230V 1~ 50Hz  
 240V 1~ 50Hz  
 100V 1~ 50Hz  
 100V 1~ 60Hz  
 120V 1~ 60Hz



- M1 Motor/motor/moteur/motor  
 C1 Betriebskondensator/capacitor/condensateur/  
 condensador de servicio  
 S1 Geräteschalter/Druckschalter/switch/pressure switch/  
 interrupteur/interrupteur a pression/interruptor/prespstato  
 F1 Thermokontakt/thermostat contact/thermo-contact/  
 termostático contacto

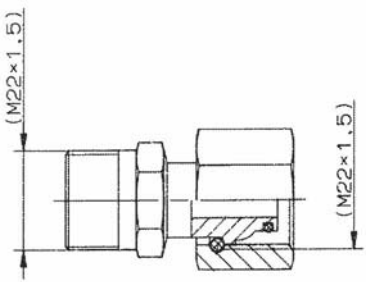
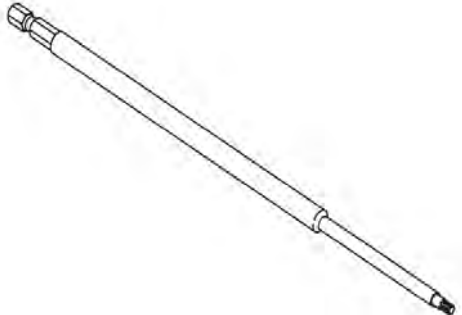
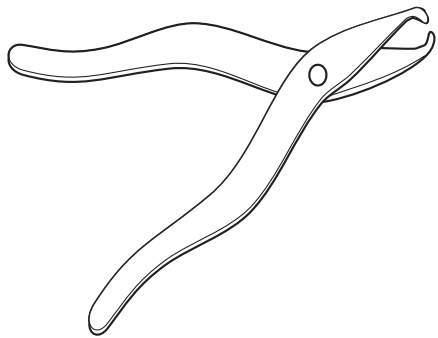
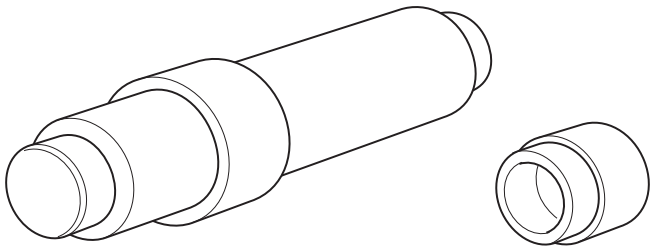
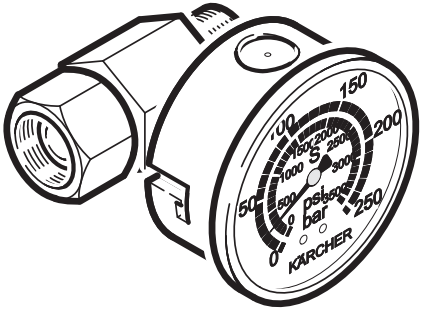
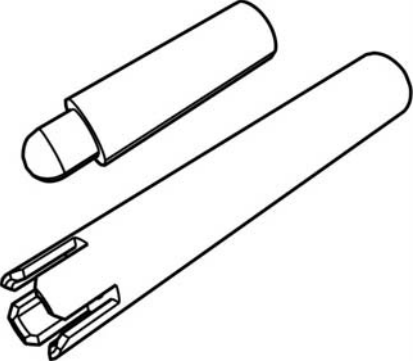

## Special tools

			
Adapter system 2000, M22x1.5 with extended union nut	4.401-072.0	Screwdriver bit T15	6.815-150.0
			
Removal pliers, pressure/suction valves and water sieves	4.901-062.0	Installation mandrel oil seal, high-pressure seal	5.901-224.0
Installation sleeve, high pressure seal		5.901-223.0	
			
Test manometer for working pressure	4.401-072.0	Valve retainer and drive-in mandrel for suction valves	2.901-049.0
			
Adapter set	2.643-037.0	Adapter	4.403-003.0



Electric measuring appliance

6.803-022.0

## Technical specifications

Electrical connection		
Voltage	230 V 1~50 Hz	
Connected load	3,0 kW	
Protection class	IP X5	
Protective class	I	
Maximum allowed net impedance	0,396 Ω + j0,248 Ω	
Mains fuse (slow-blow)	16 A	
Water connection		
Max. feed pressure	0,6 MPa	
Max. feed temperature	60 °C	
Min. feed volume	12 l/min	
Max. Suction height	0,5 m	
Performance data		
Working pressure	15 MPa	
Max. permissible pressure	16 MPa	
Water flow rate	9,2 l/min	
Max. flow rate	10 l/min	
Detergent flow rate	0,3 l/min	
Recoil force of the trigger gun	23 N	
Dimensions and weights		
Length	463 mm	
Width	330 mm	
Height	667 mm	
Weight, ready to operate with accessories	19,7 kg	
Values determined as per EN 60335-2-79		
Hand-arm vibration value	5,7 m/s <sup>2</sup>	
Uncertainty K	1,1 m/s <sup>2</sup>	
Sound pressure level L <sub>pA</sub>	80 dB(A)	
Uncertainty K <sub>pA</sub>	3 dB(A)	
Sound power level L <sub>WA</sub> + Uncertainty K <sub>WA</sub>	96 dB(A)	

Subject to technical changes.