

Spare parts list

(1.198-301.0) WD 1 Compact Battery Set *EU-II

Table of contents

WD 1 Compact Battery Set *EU-II (1.198-301.0)	3
23 Cartridge filter WD/SE (6.414-552.0)	6
30 ACCESSORIES	8

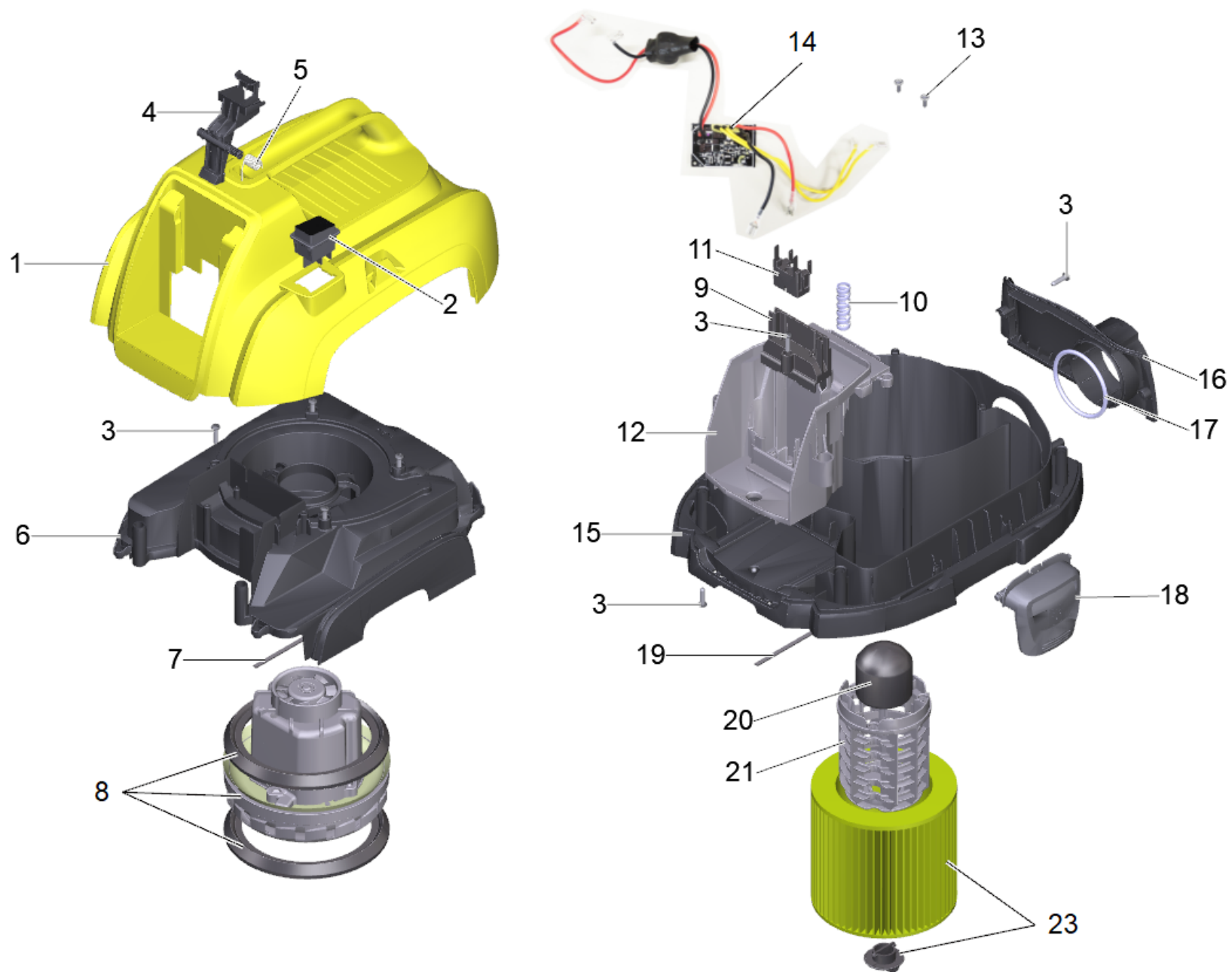

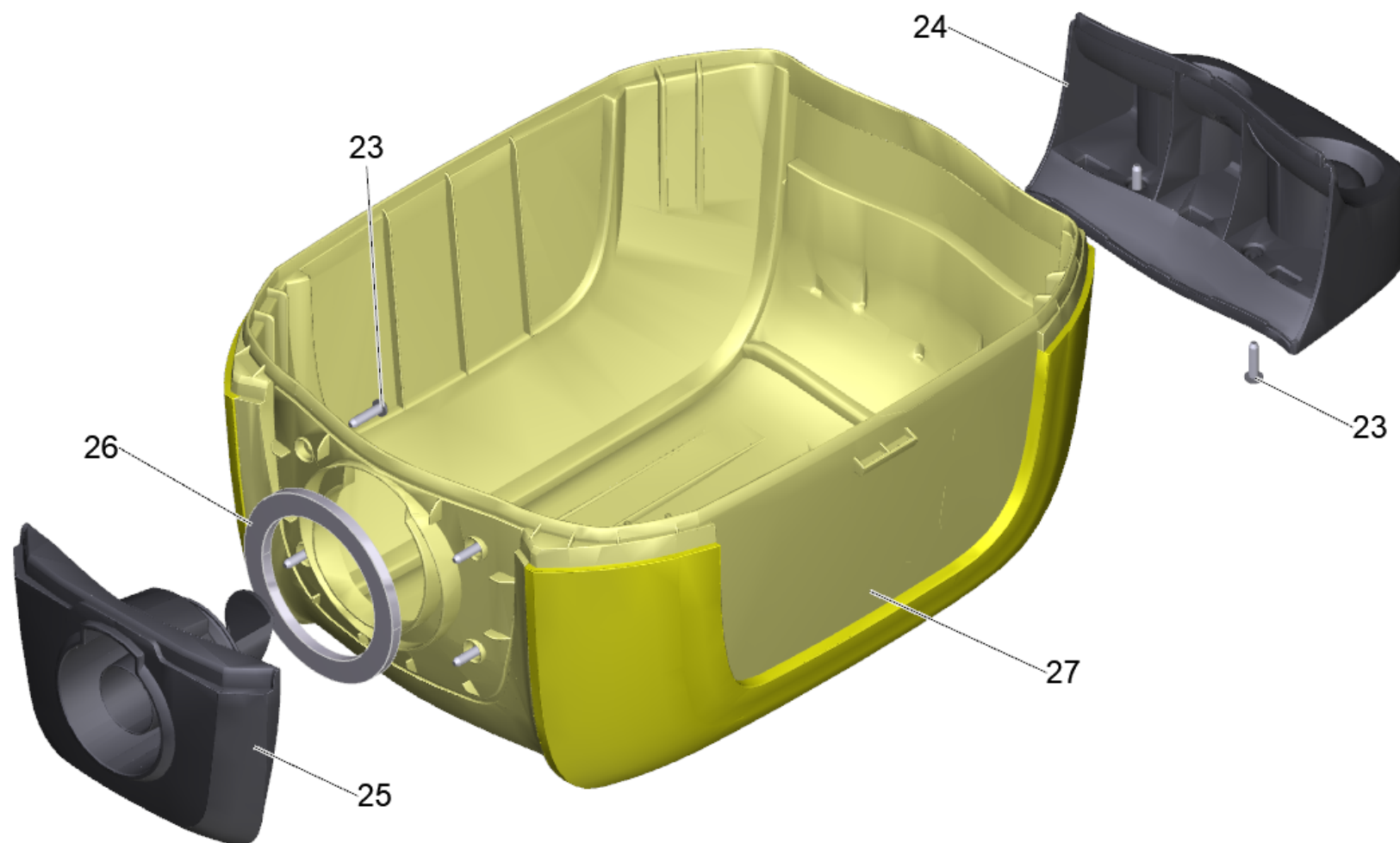

WD 1 Compact Battery Set *EU-II (1.198-301.0)

POS	Article no.	Description	Quantity	Unit
1	9.754-480.0	Cover complete for replacement	1.000	ST
2	9.765-411.0	Switch for replacement	1.000	ST
3	9.765-412.0	Screw for replacement 4x16	20.000	ST
4	9.765-265.0	Lever releasing device accumulator	1.000	ST
5	9.765-253.0	Leg spring	1.000	ST
6	9.765-257.0	Motor bracket	1.000	ST
7	9.765-418.0	Sealing motor bracket for replacement	1.000	ST
8	9.754-482.0	Motor complete for replacement	1.000	ST
9	5.445-117.0	Battery ejector 18V 2-Pins	1.000	ST
10	9.765-252.0	Spring contact unit	1.000	ST
11	9.765-413.0	Holder plug	1.000	ST
12	9.765-269.0	Cover water	1.000	ST
13	9.765-058.0	Screw for replacement 3x10	2.000	ST
14	9.765-251.0	Electronics completely	1.000	ST
15	9.754-481.0	Housing base for replacement	1.000	ST
16	9.765-259.0	Air outlet cover	1.000	ST
17	9.765-417.0	Sealing air outlet for replacement	1.000	ST
18	9.765-264.0	Tank closure	2.000	ST
19	9.765-419.0	Sealing tank for replacement	1.000	ST
20	9.765-283.0	Float	1.000	ST
21	9.765-267.0	Filter cage	1.000	ST
22	4.075-012.0	Closure complete	1.000	ST
23	6.414-552.0	Cartridge filter WD/SE	1.000	ST
24	9.765-270.0	Suction connection tank	1.000	ST
25	9.765-420.0	Seal suction connection for replacement	1.000	ST
26	9.754-483.0	Tank set for replacement	1.000	ST
27	9.765-260.0	Tank bracket	1.000	ST
30		ACCESSORIES	1.000	ST

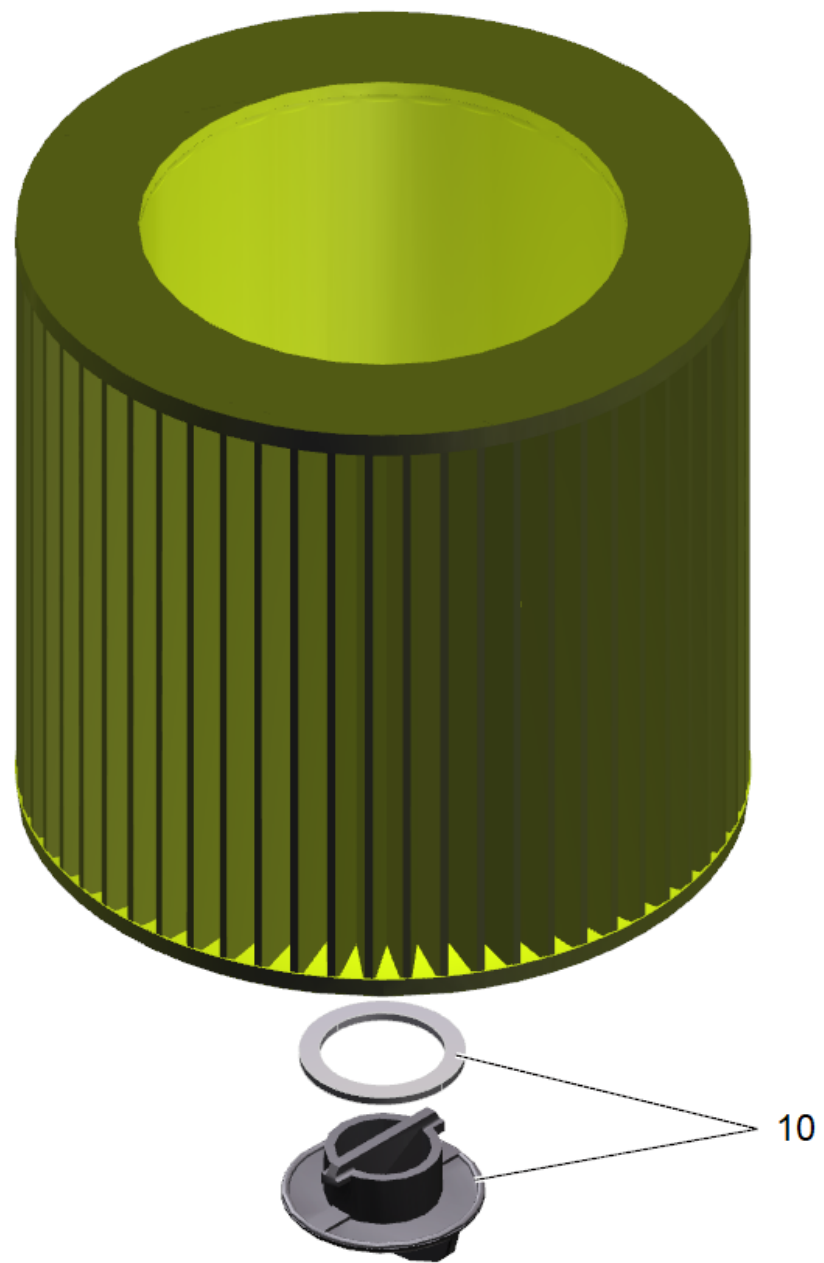

23 Cartridge filter WD/SE (6.414-552.0)

POS	Article no.	Description	Quantity	Unit
10	4.075-012.0	Closure complete	1.000	ST

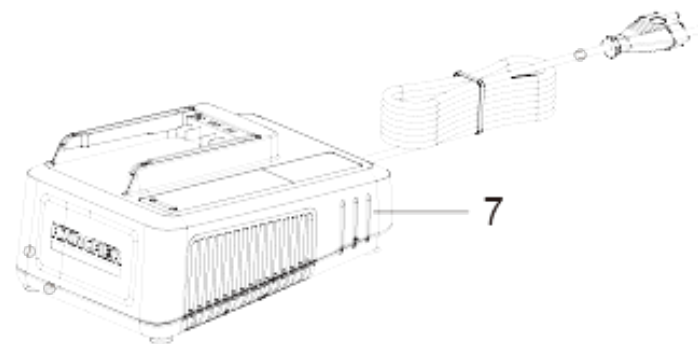
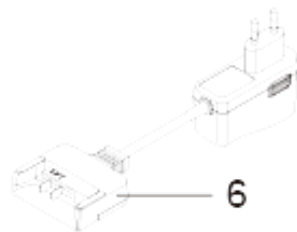
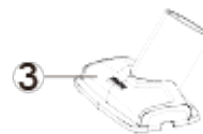
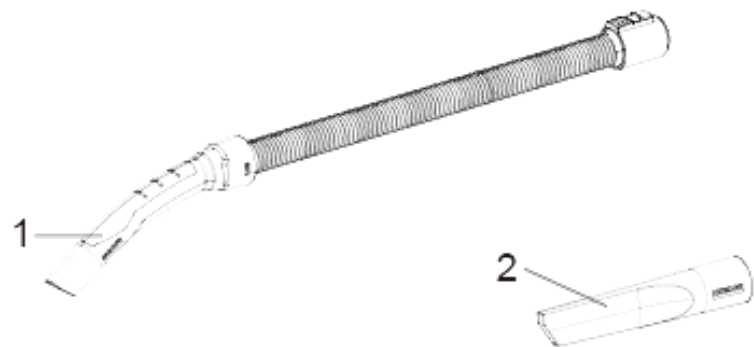

30 ACCESSORIES

POS	Article no.	Description	Quantity	Unit	Remark
1	9.754-445.0	Hose completely extruded	1.000	ST	
2	9.765-274.0	Crevice nozzle DN35	1.000	ST	
3	9.765-275.0	Upholstery nozzle DN35	1.000	ST	
4	2.863-297.0	Filter bags WD 1 Compact Battery 5pc.	1.000	ST	
5	2.445-035.0	Battery Power 18/50 DW *INT	1.000	ST	5,0Ah
5	2.445-034.0	Battery Power 18/25 DW *INT	1.000	ST	2,5Ah
6	6.445-050.3	Plug-in charger packaged 18/5 *EU	1.000	ST	
7	2.445-054.0	Universal charger Battery Power+ 18-36/60 *EU	1.000	ST	18/36V - 2,5-6,0A
7	2.445-032.0	Fast battery recharger Battery Power 18 V *EU	1.000	ST	18V/2,5A
7	2.445-044.0	Fast battery recharger Battery Power+ 18/60 *EU	1.000	ST	18V/6,0A