

23 Piston

Professional \ High pressure cleaner cold water \ Electric motor \ HD 1090 PWP *VEX \ Spare parts list HD 1090 PWP \ Pump set \ Piston

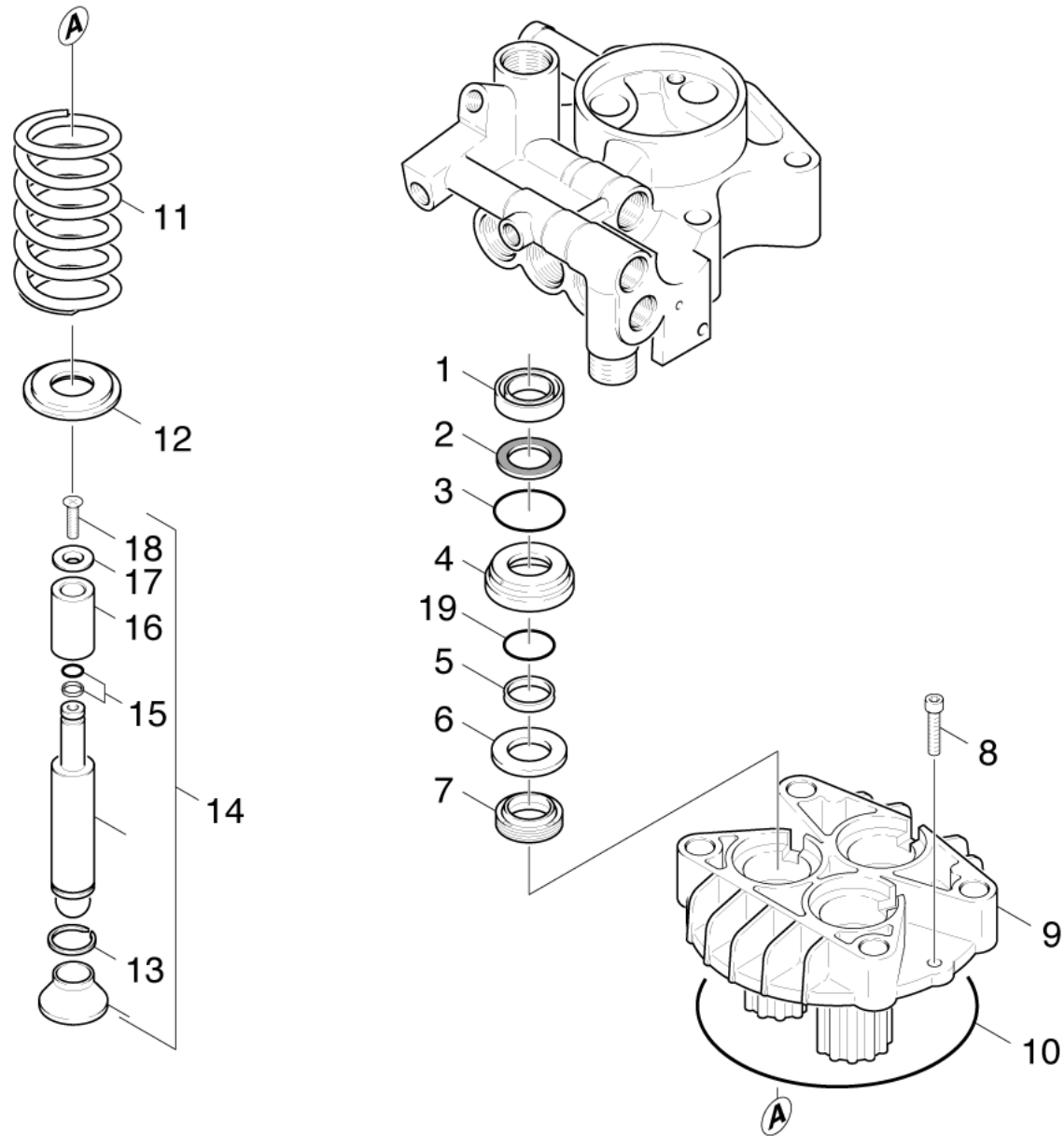

23 Piston

Professional \ High pressure cleaner cold water \ Electric motor \ HD 1090 PWP *VEX \ Spare parts list HD 1090 PWP \ Pump set \ Piston

KÄRCHER

POS	Article no.	Description	Quantity	Unit
4	5.112-521.0	Bush	3.000	ST
18	6.305-004.0	Countersunk screw M 5X 20-A2-70-sw	3.000	ST
8	7.306-023.0	Cylinder head screw M6x25 -8.8-A2E ISO4	2.000	ST
7	6.365-052.0	Grooved ring 20X28X6/8	3.000	ST
1	6.365-377.0	Grooved ring 20x30x6	3.000	ST
11	5.332-281.0	Helical spring	3.000	ST
9	5.060-460.0	Housing thrust guidance	1.000	ST
5	5.363-232.0	Joint ring	3.000	ST
19	6.362-614.0	O-Ring seal 21,0 X 4,0-FPM 83 VITON	3.000	ST
3	6.363-607.0	O-Ring seal 34,65 x 1,78 -NBR70	3.000	ST
10	6.362-796.0	O-Ring seal 107,62X 2,62	3.000	ST
15	6.362-365.0	O-Ring seal complete 1ST.-R.- 7,65X 1,7	1.000	ST
14	4.553-163.0	Piston complete	3.000	ST
16	5.110-220.3	Sleeve ceramic	3.000	ST
13	6.472-331.0	Snap ring 20	3.000	ST
2	6.365-379.0	Supportring	3.000	ST
6	5.115-680.0	Washer	3.000	ST
17	5.115-358.0	Washer	3.000	ST
12	5.115-539.0	Washer	3.000	ST