

22 Piston guidance

Professional \ High pressure cleaner hotwater \ Electric motor \ HDS 5/11 U *EU \ Spare parts list HDS 5/11 U \ Pump set \ Piston guidance

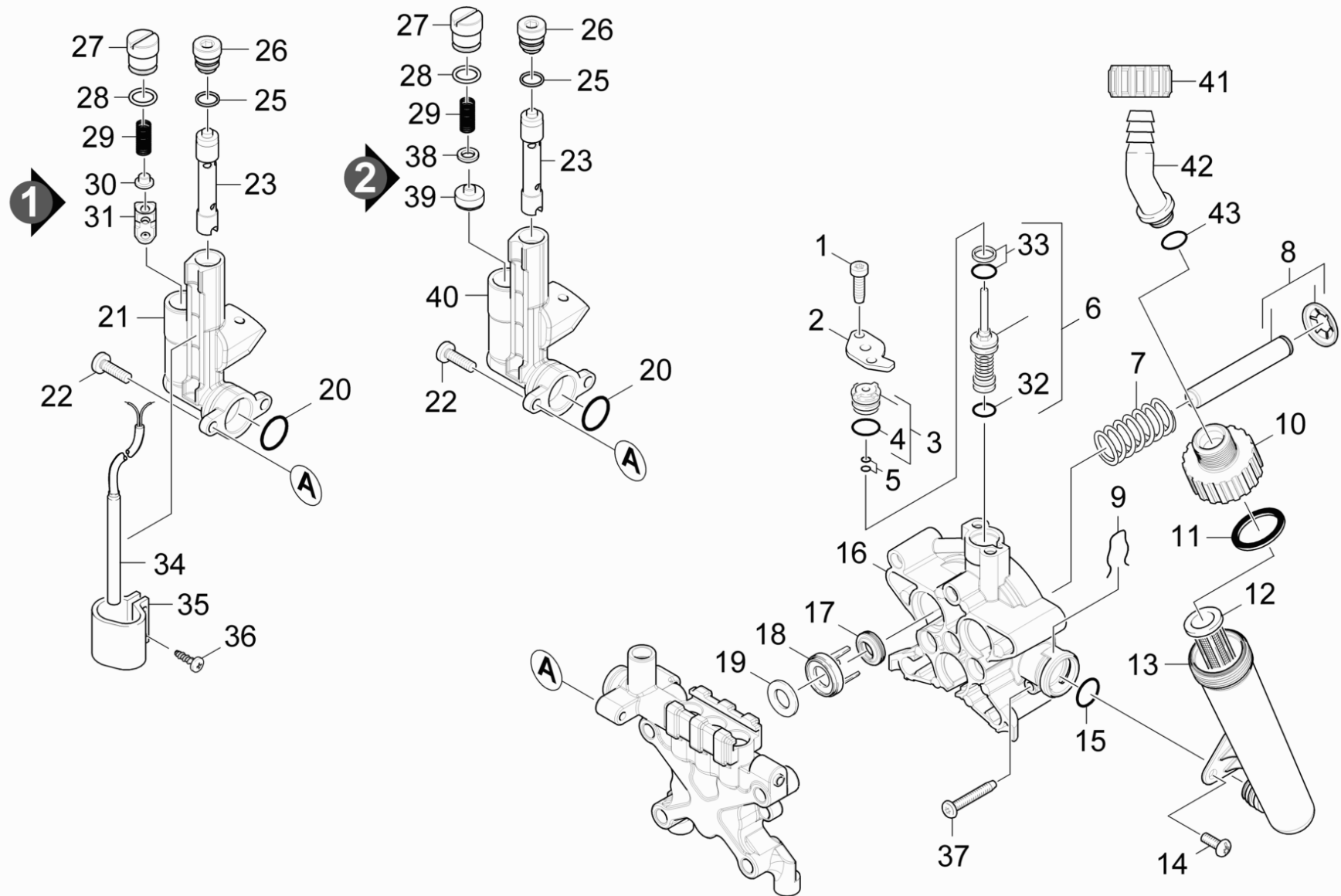

22 Piston guidance

Professional \ High pressure cleaner hotwater \ Electric motor \ HDS 5/11 U *EU \ Spare parts list HDS 5/11 U \ Pump set \ Piston guidance



POS	Article no.	Description	Quantity	Unit	Foot note text
1	7.303-048.0	Screw M6x20 -St-R3R (In6Rd)	2	PC	
2	5.064-127.0	Cover	1	PC	
3	4.030-069.0	Moulded part complete only for replaceme	1	PC	
4	6.362-169.0	O-Ring seal 12,0 X 2,0	1	PC	
5	6.362-852.0	O-Ring seal complete 3,69	1	PC	
6	4.580-325.0	Excess-current complete	1	PC	
7	5.332-391.0	Pressure spring	3	PC	
8	4.553-234.0	Piston complete only for replacement D12	3	PC	
9	5.048-915.0	Clamp	1	PC	
10	5.064-354.0	Cover water intake	1	PC	
11	5.363-336.0	Seal	1	PC	
12	5.731-587.0	Water filter	1	PC	
13	5.129-201.0	Tube water intake	1	PC	
14	7.303-037.0	Screw M5x10 -St-P2R (In6Rd)	1	PC	
15	6.363-610.0	O-Ring seal 13 x 3 -NBR	1	PC	
16	5.060-094.3	Piston guidance only for replacement	1	PC	
17	6.365-001.0	Grooved ring 12x20x4/6	3	PC	
18	5.116-062.0	Washer	3	PC	
19	5.115-721.0	Washer	3	PC	
20	6.362-580.0	O-Ring seal 17,0 X 2,0-NBR 70	1	PC	
21	2.882-702.0	Conversion kit safety system	1	PC	
22	7.306-022.0	Cylinder head screw M 6x20-8.8-A2E ISO47	2	PC	
23	4.551-058.0	Cartridge protection against water short	1	PC	
25	6.362-482.0	O-Ring seal 10 x 1,5-NBR 70	1	PC	
26	5.305-162.0	Shaped screw	1	PC	
27	5.583-096.0	Valve screw	1	PC	
28	6.362-169.0	O-Ring seal 12,0 X 2,0	1	PC	
29	5.332-414.0	Helical spring	1	PC	
30	5.584-060.0	Valve pin	1	PC	
31	4.582-019.0	Valve disc complete	1	PC	
32	6.363-614.0	O-Ring seal 9 x 2 -NBR90	1	PC	
33	6.363-174.0	O-Ring seal complete 12,42	1	PC	
34	2.883-384.0	Reed switch replacement	1	PC	

22 Piston guidance

Professional \ High pressure cleaner hotwater \ Electric motor \ HDS 5/11 U *EU \ Spare parts list HDS 5/11 U \ Pump set \ Piston guidance

POS	Article no.	Description	Quantity	Unit	Foot note text
35	5.041-076.0	Clamp	1	PC	
36	6.303-122.0	M4 .2X13 DIN 7981 TORX T15 PAN HD HI/LO	1	PC	
37	7.303-043.0	Screw M5x30-ST-A2R (IN6RD)	2	PC	ASSEMBLING AID
38	5.115-260.0	Washer	1	PC	
39	5.581-349.0	Valve disc	1	PC	
40	5.427-454.3	Manifold	1	PC	
41	5.310-062.0	Nut	1	PC	
42	5.443-285.0	Hose stem	1	PC	
43	6.362-078.0	O-Ring seal 13,3x2,4	1	PC	